

# **BRIDGESTONE**

## **HYDRAULIC HOSE**

**Couplings , Accessories and Equipment**





## Warning



## Caution

- Bridgestone Products (hereinafter “Products”) are the part of the engineered systems which are manufactured by Bridgestone and must be assembled and used on the basis of Bridgestone’s instructions, processes and specifications.
- Failure to follow the warnings set forth on the Products or in this catalog may result in serious injury or death. In the event users fail to follow usage instructions or specifications, which Bridgestone stipulates in the catalog, Bridgestone neither guarantees the performance of the Products nor is responsible for any other product-related failures/defects.
- Bridgestone disclaims any responsibilities or liabilities for any components in the engineered system which are not designed, engineered or produced by Bridgestone.
- Bridgestone is not responsible for the performance of the Products assembled by others in a manner which does not conform to Bridgestone instructions, processes or specifications.
- Warning indicates that failure to comply with the instructions may cause personal injury or death.
- Caution indicates that failure to comply with the instructions may cause personal injury or property damage.

## DISTRIBUTION OF INFORMATION

**Bridgestone** widely distributes the Products and usage information to distributors, sellers and users.

This information is also available on Bridgestone’s website, ([www.bridgestone.com/products/diversified/hose](http://www.bridgestone.com/products/diversified/hose)). However, we also rely on the sellers or distributors of the Products to provide a copy of safety or usage information, including warnings and precautions to all end users.

It is imperative to read these warnings and precautions before selecting and utilizing the Products.

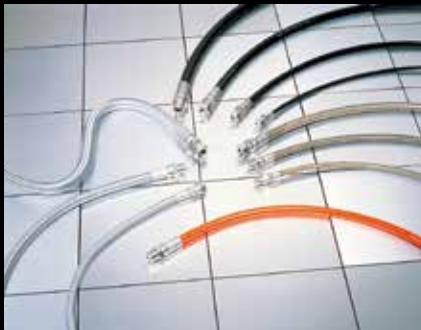

## Contents

▶ Contents .....	1
▶ Precautions .....	2
▶ Symbols .....	3~4
▶ How to Order .....	5
▶ Thread Identification .....	6
▶ Hose Summary .....	7~10
▶ Hoses and Couplings .....	11
▶ OKE .....	12
▶ PA .....	12~14
▶ PF .....	15
▶ HQ35 / CQ36 / SQ28 .....	16
▶ EQ .....	17~18
▶ SAE / DIN .....	19~20
▶ Special Application Rubber Hoses .....	21~26
▶ Couplings .....	27
AS / LS / UT / UN / LC .....	27~29
UL / UX .....	30~33
UB / UZ .....	34~40
HW / KH / KN / KD / EX .....	41~46
EA / EC / EK / GA / GB / UF / UZ / ZP .....	47~49
▶ PASSTAGE LINE .....	50
▶ Special Application Resin Hoses .....	51
▶ Couplings .....	52
CY / CW / JG / JY / SG / SH / SY / UY .....	52~53
▶ Bridgestone SELFIT .....	54~58
▶ Bridgestone Primo Line .....	59~63
▶ Adapters .....	64~65
▶ Split Flanges .....	66~67
▶ BI - Coupler .....	68~71
▶ Swivel Joints .....	72~75
▶ Accessories for Protection .....	76~78
▶ How to calculate Hose Exposed Length .....	79
▶ Hose Assembly Installation .....	80
▶ Relational Table of Flow Rate / Velocity / Hose Size .....	81
▶ Tightening Torque .....	82
▶ Certificate of Compliance with the Marine Standard .....	83
▶ Crimping Machine <UNICRIMP> .....	84

# Precautions

For Safety's sake

Be sure to read the following before use.

- 1** Bridgestone Hydraulic hose, couplings, and accessories are developed for hydraulic components.  
Follow each product's application and specification.  
Avoid hose burst, leakage, and other dangers by following important steps.

## 1 Proper usage

**Warning** Severe personal injury or death may result if these instructions are not followed.

- **Do not touch a pressurized hydraulic hose assembly with any part of your body.**  
If hoses, couplings or accessories are broken, and a fluid touches the skin, even if no pain is felt, a serious injury including burns may be caused. In case of JAT/JAM series, be sure to use safety chains. Use of plastic hose guards will help a person avoid injury.
- **System working pressure should not exceed the rated working pressure of the hose assembly.**  
Exceeding the rated working pressure of the hose may result in the hose bursting or hose coupling blow-off.  
Follow the maximum working pressure ratings listed in this catalog.
- **Use compatible hydraulic fluid**  
The use of an incompatible hydraulic fluid will deteriorate the inner tube and the reinforcement resulting in the hose bursting or coupling hose coupling blow-off.
- **Protect hose from abrasions.**  
If the hose reinforcement is exposed, it is susceptible to rust and accelerated damage leading to serious failure like hose burst. If it is found, replace with a new one.
- **Avoid applications where the hose is or will be twisted or pulled.**  
Twisting or stretching a hydraulic hose under pressure may result in hose bursting or hose coupling blow-off.  
If it is found, replace with a new one, then install a live swivel joint.
- **Do not snap the hose.**  
Snapping and deforming will lead to hose burst, leakage, and hose coupling blow-off. If found, replace with a new one.
- **Do not apply an electrical current to a hose assembly.**  
Electrifying a hose may lead to a hose failure or an electric shock.
- **Tighten hose assemblies to the recommended torque.**  
If tightening is improper, there are possibilities of leakage, connection portion breakage, and separation. Be sure to apply the recommended torque by using a torque spanner. In case of over torque, replace with a new one. In case of under torque, retighten with the recommended torque ( page 82 ).
- **Avoid the usage exceeding the minimum bending radius**  
The usage exceeding the minimum bending radius may cause hose burst and leakage. Be sure to follow the specified minimum bending radius.
- **Avoid excessive vibration**  
The usage excessive vibration may cause leakage and hose coupling blow-off by fatigue.
- **Avoid the usage exceeding applicable temperature**  
The usage exceeding applicable temperature may cause leakage and hose coupling blow-off.

**Caution** Personal injury or property damage may result if these instructions are not followed

- **Avoid vacuum pressure (except for suction hose)**  
Excessive vacuum pressure may result in the inner tube damage which leads to hose failure.
- **Avoid submerging hose assemblies in water or any other liquid.**  
Hose assemblies submerged in water are exposed to external pressure which will reduce the service life of a hose and/or have bad effect on hose assembly performance.
- **Remove all air from hydraulic hose assemblies.**  
Air may cause damage to the inner tube which will lead to hose failure.
- **Follow minimum hose exposed length**  
Follow minimum hose exposed length. Improper length may result in inferior performance to catalog specification.
- **Never repair or rework a hose assembly.**  
Old or used hose assemblies do not have the same physical characteristics as a new hose and cannot be used.  
Old hoses or damaged hoses should be replaced with new one, and should not be repaired or reworked.
- **Do not use for food or drinking water, since the hose is intended for industrial use.**

## 2 Warranty period

Warranty period is impulse cycle number or each specified period, whichever comes earlier (Refer to pages 7 to 10).

## 3 Preventive maintenance

Before use, check for the following conditions. If any are found, replace with a new part.  
Physical damage, blister, exposed reinforcement, kinking, hose coupling blow-off, leakage etc.  
JIS B8360,8362,8364 recommend that hoses should be changed every 2 years.

## 4 Storage

- Cap the couplings or hose cut ends
- Keep out of direct sunlight
- Do not expose to corrosive gas, oil or chemicals
- Store in dark and dry place at the temperature between -10°C and +40°C (14°F to 104°F)

This catalog shows the product specifications in the format below so you can select the correct product for your needs and prevent the risk of danger.

## Hose

Hoses are flexible tubes designed to carry fluid from one location to another or to convey pressure. Typically, they include rubber hoses (**PASCALART**, **EPOQU**, etc.) and resin hoses (**PASSTAGE LINE**, etc.).

### [Example Specifications of Hoses]

**Pressure**  
Pressure shown in psi/MPa units

**Catalog Number**  
When ordering a product, specify its catalog number.  
*\*For details, refer to page 5.*

**Temperature Range : ambient**  
Permissible temperatures of ambient environment for the hose

**Inner Tube**  
Inner part of the hose, which comes into direct contact with the fluid  
The specifications show the materials for this part.

**Outer Cover**  
Outer part of the hose, which is intended to protect its reinforcing  
The specifications show the materials for this part.  
*\*The color of this cover is black unless otherwise specified.*

**Temperature Range: fluid**  
Permissible temperatures of fluid flowing through the hose

**Compatible Fluid**  
Fluid applicable to the hose

- Compatible Fluid / Mineral Hydraulic Oil
- Temperature Range: fluid / -40°C to 100°C / -40°F to 212°F
- Temperature Range: ambient / -40°C to 70°C / -40°F to 158°F
- Inner Tube / Oil-resistant synthetic rubber
- Outer Cover / Weather-resistant synthetic rubber

**Weight**  
Approximate Weight of Hose

**PA01**

Maximum Working Pressure

**1.5MPa  
500PSI**

Catalog Number	I.D.		O.D.		Max.W.P.		Min.B.P.		Min.B.R.		Weight		Reinforcement	Compatible coupling/relevant page	
	inch	mm	inch	mm	psi	MPa	psi	MPa	inch	mm	lbs/ft	g/m		Factory-assembled	UNICRIMP-cripped
PA0104*	1/4	6.3	0.55	14.0	200	1.5	870	6.0	2.17	55	0.33	150	4C	AS/27	AS/27 UL/30
PA0106*	3/8	9.5	0.69	17.4					2.56	65	0.53	240			
PA0108*	1/2	12.7	0.83	21.2					3.54	90	0.62	280			

**I.D·O.D**  
Inner and outer diameters of the hose

**Max.W.P.**  
Maximum usable working pressure

**Min.B.R.**  
Minimum bending radius that can be achieved without performance degradation. This radius is specified on the inside surface of the bend area.

**Min.B.P.**  
Pressure that the hose should withstand without problems such as coupling detachment, hose bursting, and fluid leaking from the crimped part when the hose is subjected to water or oil pressure.

**Coupling Series**  
Series of couplings that are crimped either **at a factory** or **with UNICRIMP**. The number after "/" indicates the number of the page that describes the applicable series of couplings.  
*\*Crimping the couplings may be impossible depending on the type of UNICRIMP used.*

**Reinforcement**  
Fibers or wires woven or spirally wrapped around an inner tube to maintain hose performance. The specifications show the structure of the reinforcing.

## Couplings

Couplings for connecting the hose to equipment. Usually, a crimping machine is used to crimp the couplings onto the hose.

### [Example Specifications of Couplings]

Type of End-configuration.

**R**

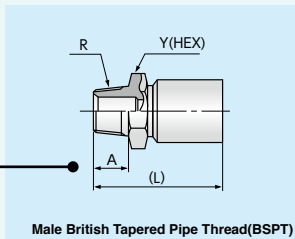

Standard product — Material: SS or SC equivalent steel, Surface: Zinc plating or chromate treatment

#### Catalog Number

When ordering a product, specify its catalog number.

\*For details, refer to page 5.

Catalog Number	Thread	Y		A		(L)		Weight	
		inch	mm	inch	mm	inch	mm	lbs	g
UZ04R	1/4	0.67	17	0.51	13	1.97	50	0.11	50
UB06R	3/8	0.75	19	0.59	15	2.28	58	0.19	85
UB08R	1/2	0.87	22	0.71	18	2.52	64	0.28	125
UZ08R	1/2	0.87	22	0.71	18	2.52	64	0.28	125
UB1012R	3/4	1.18	30	0.79	20	3.07	78	0.49	220
UB12R	3/4	1.18	30	0.79	20	3.35	85	0.63	285
UB16R	1	1.42	36	0.87	22	3.66	93	0.95	430
UZ20R	1 1/4	1.81	46	0.99	25.2	4.80	122	1.91	865

#### Shape of Crimped Couplings

This figure shows a coupling before crimping. The shape of crimped couplings varies depending on the crimping machine used.

#### Surface Treatment of Standard Products

The specifications show the treatment method used to prevent metal fittings from becoming rusted.

### Combinations of Hoses and Couplings

The combinations of hoses and couplings comply with JIS B 8363 (End fittings for hydraulic hose assemblies). For assured quality, be sure to properly tighten the couplings using the **torques** shown on page 82.

#### Applicable working Pressure of each thread (JIS B 8363)

Unit : MPa(psi)

Thread \ Size	02	04	05	06	08	10	12	16	20	24	32
<b>R</b>	41.0		—	34.5						20.5	
<b>G, C, F, F2</b>	—	34.5				27.5		20.5	17.0	10.5	
<b>Q2</b>	—	41.5					34.5		27.5	—	
<b>S, SR(SAE standard)</b>	—	—	—	—	34.5				24.5	20.5	
<b>H, HR(SAE H.P)</b>	—	—	—	—	34.5						
<b>K, K1~K7 (21MPa flange)</b>	—	—	—	—	20.5						

Accurate Tightening Torque (page 63) is required to achieve the above pressure.

# How to Order

Below are examples of the catalog numbers shown in this catalog.

## HOSE Example of hose catalog numbers

(Pressure-rated hose)

**PA 07 04**

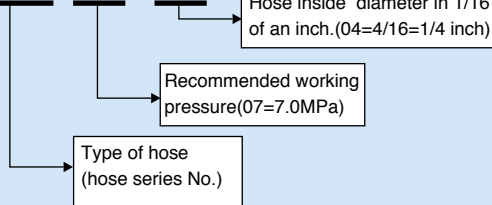

(SAE hose)

**R1T 08**

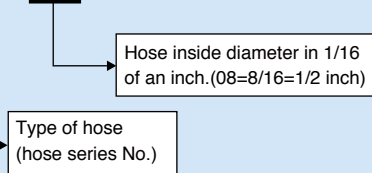

## COUPLING

**UB 08 R**



Hose inside diameter connected to couplings and thread size in 1/16 of an inch. (08 = 8/16 = 1/2inch)  
 • In case of jump size coupling.  
 For Example, if hose ID is 5/8" (=10/16") and thread size is 3/4" (=12/16"), UA1012R is the catalog number.

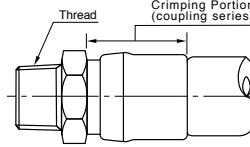

## Adaptor

**80 01 RG 08**

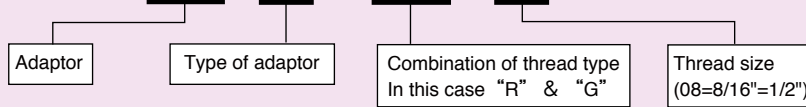

### [HOSE LENGTH (L)]

Please refer to the figures below when you specify the assembly length.

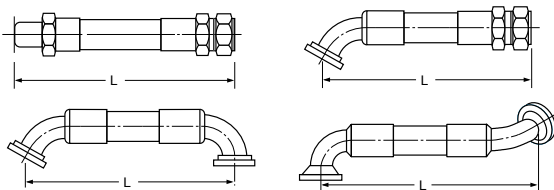

### [Orientation Angle]

Bent tube ends and flange head couplings can be oriented at different angles to one another and must be specified when ordering. As per the illustration right, the orientation angle is measured starting from either end as the far end, clockwise to the near end. In the case of illustration right, the orientation angle is 225°.

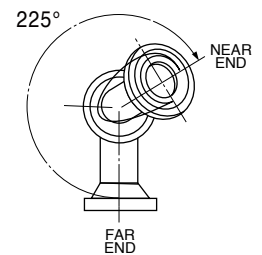

## Selecting the proper hose

Please check below points.

- ① Fluid to be used.
- ② Delivery (flow rate and velocity) or Hose ID (Please refer "Pressure Loss" in this catalog)
- ③ Maximum working pressure.
- ④ Fluid and ambient Temperature.
- ⑤ Thread type.
- ⑥ Hose Length (Please refer [Hose Length(L)] above and "Hose exposed length calculation" in this catalog)
- ⑦ Orientation angle (Please refer above [Orientation Angle])
- ⑧ Application and Environmental Conditions.
- ⑨ Minimum bending Radius.
- ⑩ Drawing.

### Ordering Method

① To order assembled hoses, specify the following (typical examples of data):

Hose catalog No.	× Hose length		
PA2108	×1,000(L)		
Coupling at one end	Coupling at the other end	Hose adaptor	No.
UZ08R	UZ08C	8002RG08	10

② To order hoses and fittings separately, specify the following:

Hose catalog No.	× Hose length	Fittings catalog No.	No. of pieces	OR	Hose catalog No.	× Hose length
PA2108	×60,000(L)	UZ08R	10		PA2108	×30,000(L)
		UZ08R	10		No.	
		8002RG08	10			
						2

# Thread Identification

- The coupling threads shown below are available. They comply with the JIS and ISO standards. The types of coupling threads are designated "R," "F," etc. These are included in the catalog numbers.
- A series of couplings is available for each hose. The standard coupling threads differ for each series of couplings. For details, refer to the coupling specifications.
- Standard products are made from SS or SC equivalent steel processed with a surface treatment (zinc plating or chromate treatment). Products made from stainless steel or brass are also available. For details, contact us.

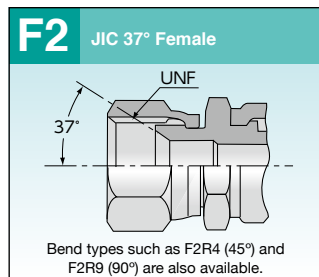
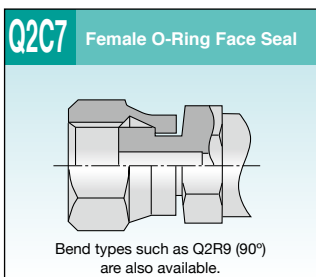
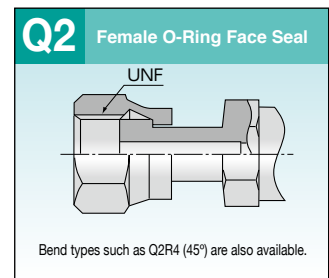
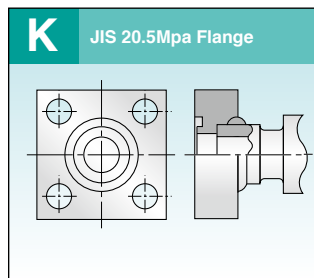
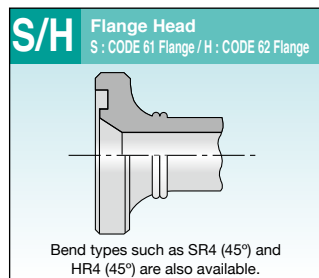
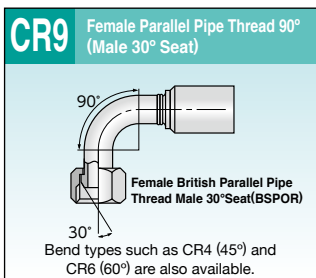
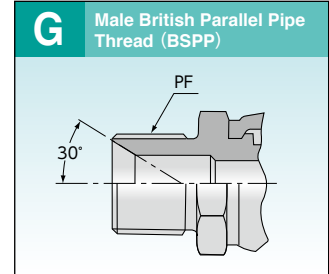
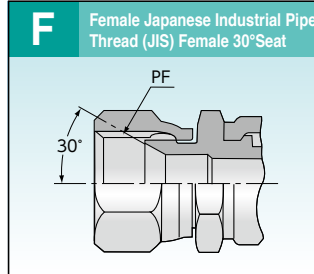
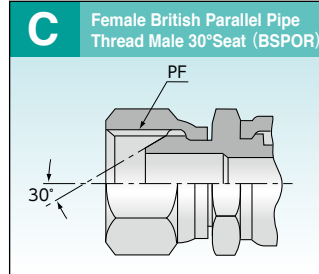
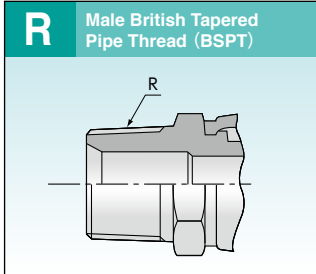

- The following non-standard products are also available. For details, contact us.

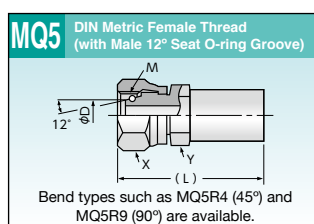
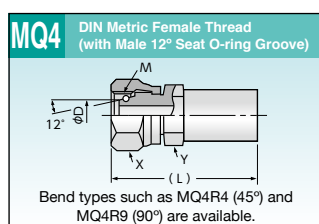
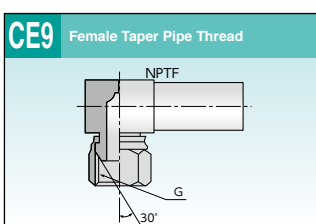
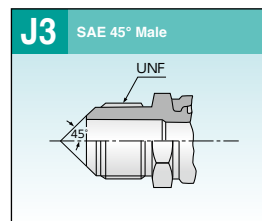
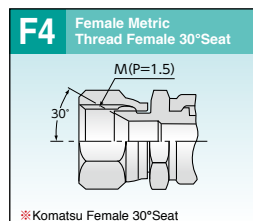
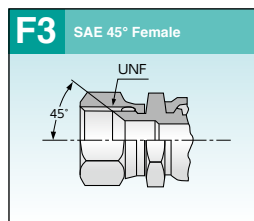
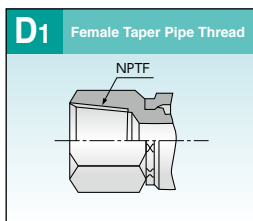
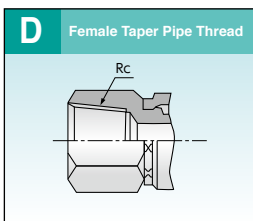
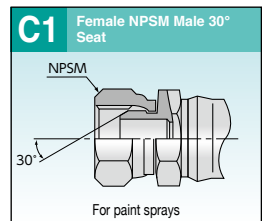
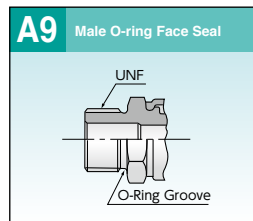
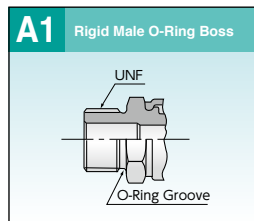
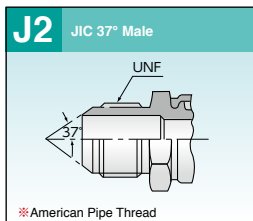
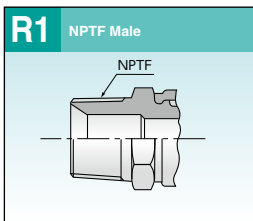

\* Coupling materials are carbon steel with zinc plating

\* As for PrimoLine series, coupling type is special one. Please see PrimoLine page (page 59).



# Hose Summary

HOSE			Series	Low-pressure rubber hoses	Standard Rubber Hoses										Slim Rubber Hoses						
Inner Diameter	Code	Type	OKE	PASCALART										PASCALART-f							
			inch	mm	OKE	PA01	PA03	PA07	PA10	PA14	PA17	PA21	PA28	PA35	PF07	PF14	PF17	PF21	PFW	PFH	
1/8	3.2	02	Maximum working pressure MPa																		
3/16	4.8	03																			
1/4	6.3	04		1.5	1.5	3.5	7.0	10.5	14.0	17.0	20.5	27.5	34.5	7.0	14.0	17.0	20.5	24.5	27.5		
5/16	7.9	05																			
3/8	9.5	06		1.5	1.5	3.5	7.0	10.5	14.0	17.0	20.5	27.5	34.5	7.0	14.0	17.0	20.5	24.5	27.5		
1/2	12.7	08		1.5	1.5	3.5	7.0	10.5	14.0	17.0	20.5	27.5	34.5	7.0	14.0	17.0	20.5	24.5	27.5		
5/8	15.9	10		1.5		3.5	7.0	10.5	14.0	17.0	20.5	27.5	34.5					20.5			
3/4	19.0	12		1.5		3.5	7.0	10.5	14.0	17.0	20.5	27.5	34.5					20.5			
7/8	22.2	14																			
1	25.4	16		1.5		3.5	7.0	10.5	14.0	17.0	20.5	27.5	34.5					20.5			
1-1/4	31.8	20				3.5	7.0	10.5	14.0		20.5	27.5	34.5								
1-1/2	38.1	24				3.5	7.0	10.5	14.0		20.5	27.5	34.5								
2	50.8	32					7.0	10.5	14.0		20.5	27.5	34.5								
2-1/2	63.5	40																			
3	76.2	48																			
Relevant page				12		12~14						15									
Minimum burst pressure (MPa)				3×		4× Maximum working pressure															
Fluid temperature (°C)				-40 to+100(oil) 0 to +50(water) -40 to +60(water-glycol)			-40 to+100			-40 to +100 (oil), -40 to+60 (water-glycol)			-40 to+100								
Recommended ambient temperature (°C)				-40 to +70 (oil) 0 to +70 (water) -40 to +60(water-glycol)			-40 to +70			-40 to +70 (oil), -40 to+60 (water-glycol)			-40 to +70								
Compatible fluid				Mineral hydraulic oil, water, water-glycol			Mineral hydraulic oil			Mineral hydraulic oil, water-glycol			Mineral hydraulic oil								
Uses and features				Low-pressure, lightweight		Ordinary hydraulic piping						Abrasion-resistant slim type for ordinary hydraulic piping									
Warranty period			Period	1 year																	
			No. of times used	400,000																	

\*Warranty is effective until the predetermined usage period expires or the impulse cycle count reaches the predetermined value, whichever occurs first. (The impulse cycle count refers to the number of times the hose has been pressurized under the specified hose usage conditions.)

## COUPLING

\*For information about other couplings, contact us. For information about adapters, refer to pages 64 and 65.

Hose type		OKE	PA01	PA03	PA07	PA10	PA14	PA17	PA21	PA28	PA35	PF07	PF14	PF17	PF21	PFW	PFH	
Coupling thread type	Relevant page	27~29	27~33			34~44						34~39						
	R	●	●	●	●	●	●	●	●	●	●	●	●	●	●	●	●	●
	F	●	●	●	●	●	●	●	●	●	●	●	●	●	●	●	●	●
	C	●	●	●	●	●	●	●	●	●	●	●	●	●	●	●	●	●
	G	●	●	●	●	●	●	●	●	●	●	●	●	●	●	●	●	●
	CR	●	●	●	●	●	●	●	●	●	●	●	●	●	●	●	●	●
	S	●	●	●	●	●	●	●	●	●	●	●	●	●	●	●	●	●
	SR	●	●	●	●	●	●	●	●	●	●	●	●	●	●	●	●	●
	H										●	●						
	HR										●	●						
	K~K4				●	●	●	●	●	●			●	●	●	●	●	●
	K~K3R				●	●	●	●	●	●			●	●	●	●	●	●
	F4	●	●	●	●	●	●	●	●	●	●	●	●	●	●	●	●	●
	F2	●	●	●	●	●	●	●	●	●	●	●	●	●	●	●	●	●
	F2R	●	●	●	●	●	●	●	●	●	●	●	●	●	●	●	●	●
	Q																	
Q2	●	●	●	●	●	●	●	●	●	●	●	●	●	●	●	●	●	
Q2R	●	●	●	●	●	●	●	●	●	●	●	●	●	●	●	●	●	

# Hose Summary

HOSE			●Hose Available Only																	
Series			Slim Rubber Hoses			120°C Rubber Hoses					SAE / DIN Hoses									
Inner Diameter		Code	Type	HQ	CQ	SQ	EPOQU					SAE Series					DIN Series			
inch	mm			HQ35	CQ	SQ28	EQ17	EQ21	EQ25	EQ28	EQ31	R1AT	R2AT	R12A	R13A	R15A	4SP	4SH		
1/8	3.2	02	Maximum working pressure MPa																	
3/16	4.8	03																		
1/4	6.3	04			36.0							22.5	40.0							
5/16	7.9	05																		
3/8	9.5	06			36.0							18.0	33.0	28.0		42.0	44.5			
1/2	12.7	08			34.5	36.0	27.5	17.0	20.5	24.5	27.5	31.0	16.0	27.5	28.0		42.0	41.5		
5/8	15.9	10			34.5	36.0	27.5	17.0	20.5	24.5	27.5	31.0	13.0	25.0	28.0			35.0		
3/4	19.0	12			34.5	38.0	27.5	17.0	20.5	24.5	27.5	31.0	10.5	21.5	28.0	35.0	42.0	35.0	42.0	
7/8	22.2	14																		
1	25.4	16			34.5	38.0		17.0	20.5	24.5	27.5	31.0	8.7	16.5	28.0	35.0	42.0	28.0	38.0	
1-1/4	31.8	20			34.5	38.0		17.0	20.5	24.5	27.5	31.0	6.2	12.5	21.0	35.0	42.0	21.0	32.5	
1-1/2	38.1	24						17.0	20.5	24.5	27.5	31.0	5.0	9.0	17.5	35.0	42.0	18.5	29.0	
2	50.8	32							20.5			31.0	4.0	8.0	17.5	35.0			25.0	
2-1/2	63.5	40																		
3	76.2	48																		
Relevant page				16			17~18					19~20								
Minimum burst pressure (MPa)				4× max.working pressure			5× Maximum working pressure					—								
Fluid temperature (°C)				-40 to +100 (-40 to +120(CQ38))			-40 to +120					—								
Recommended ambient temperature (°C)				-40 to +70			-40 to +70					—								
Compatible fluid				Mineral hydraulic oil			Mineral hydraulic oil					—								
Uses and features				Impulse cycle 1,200,000	MSHA Approved	Ultra High Abrasion	Maximum fluid temperature 120°C					—								
Warranty period				Period	1 year			1 year					—							
				No. of times used	1,200,000	1,000,000	400,000	1,000,000					—							

\*Warranty is effective until the predetermined usage period expires or the impulse cycle count reaches the predetermined value, whichever occurs first. (The impulse cycle count refers to the number of times the hose has been pressurized under the specified hose usage conditions.)

## COUPLING

\*For information about other couplings, contact us. For information about adapters, refer to pages 64 and 65.

Hose type		HQ35	CQ	SQ28	EQ17	EQ21	EQ25	EQ28	EQ31	R1AT	R2AT	R12A	R13A	R15A	4SP	4SH	
Coupling thread type	Relevant page	34~39			27~33												
	R	●	●	●	●	●	●	●	●								
	F	●	●	●	●	●	●	●	●								
	C	●	●	●	●	●	●	●	●								
	G	●	●	●	●	●	●	●	●								
	CR	●			●	●	●	●	●								
	S	●		●	●	●	●	●	●								
	SR	●			●	●	●	●	●								
	H	●	●	●	●	●	●	●	●								
	HR	●			●	●	●	●	●								
	K~K4				●	●											
	K~K3R				●	●											
	F4	●	●		●	●	●	●	●								
	F2	●	●		●	●	●	●	●								
	F2R	●			●	●	●	●	●								
	Q		●														
	Q2	●	●	●	●	●	●	●	●								
	Q2R	●			●	●	●	●	●								

HOSE																			
Series			Inner Diameter	Rubber Hoses for Jacks		Suction Hoses	Rubber Hoses (lightweight, flexible) for water cleaning		Hoses for steam cleaning	Heat/oil-resistant Hoses	Push-on Hoses	Hoses for hot cleaning	Hoses for both water-glycol and mineral oil		Air Hoses	Large-bore high-pressure Hoses			
				JW·JWK	VW	WA·WAR	SA	HM	ACT	WH	WE		PA03-DA	JUMBO ACE					
inch	mm	Code	Type	JW70	JWK	VW	WA14	WAR	SA	HM	ACT	WH21	WE21	WE28	PA03-DA	JBT	JBF	JBS	
1/8	3.2	02	Maximum working pressure MPa																
3/16	4.8	03																	
1/4	6.3	04		68.5	137.0		14.0	20.5				2.0		20.5	27.5	3.5			
5/16	7.9	05																	
3/8	9.5	06		68.5	98.0		14.0	20.5			2.0	20.5	20.5	27.5	3.5				
1/2	12.7	08		68.5	98.0		14.0	20.5	2.0		2.0		20.5	27.5	3.5				
5/8	15.9	10																	
3/4	19.0	12								2.0	7.0			20.5	27.5	3.5			
7/8	22.2	14																	
1	25.4	16				3.0				2.0	7.0			20.5	27.5	3.5			
1-1/4	31.8	20				3.0								20.5	27.5				
1-1/2	38.1	24				3.0								20.5	27.5				
2	50.8	32				3.0								20.5	27.5				
2-1/2	63.5	40															4.9	14.0	20.5
3	76.2	48															3.0	10.5	17.0
Relevant page				21			22			23			24		25	26			
Minimum burst pressure (MPa)				About 2× maximum working pressure		4× max. working pressure	About 2.5× max. working pressure		6× max. working pressure	4× max. working pressure	5× max. working pressure	3× max. working pressure	4× max. working pressure		About 4× max. working pressure				
Fluid temperature (°C)				-40 to +100		0 to +80		+4 to +210	-40 to +135	-40 to +93(oil), 0 to +50 (water)	0 to +120	-40 to +60 (water-glycol), -40 to +100 (oil)		-40 to +60	-40 to +100				
Recommended ambient temperature (°C)				-40 to +70		-40 to +70			-40 to +100	-40 to +70(oil), 0 to +70 (water)	-40 to +70	-40 to +60 (water-glycol), -40 to +70 (oil)		-40 to +60	-40 to +70				
Compatible fluid				Mineral hydraulic oil		Water		Steam	Mineral hydraulic oil/mineral engine oil	Mineral hydraulic oil/water	Hot water	Water-glycol and mineral hydraulic oil		Air	Mineral hydraulic oil				
Uses and features				For ultra high pressure hydraulic tools		Max. negative pressure -0.08665MPa	Cleaning/green cut/peeling		Steam cleaning	Heat resistance	Crimping machine not required	Hot cleaning	Injection steel plants		Air supply	Large bore, large flow volume, max. length of 40m			
Warranty period			Period	1 year		6 months		3 months	1 year	1 year (oil)/6 months (water)	6 months	1 year		1 year	1 year				
			No. of times used	25,000	200,000	100,000	—	400,000	100,000	400,000	—	200,000							

\*Warranty is effective until the predetermined usage period expires or the impulse cycle count reaches the predetermined value, whichever occurs first. (The impulse cycle count refers to the number of times the hose has been pressurized under the specified hose usage conditions.)

COUPLING																	
Hose type		JW70	JWK	VW	WA14	WAR	SA	HM	ACT	WH21	WE21	WE28	PA03-DA	JBT	JBF	JBS	
Relevant page		27~33						34~46									
Coupling thread type	R	●	●	●	●	●	●	●	●	●	●	●	●	●			
	F			●	●	●	●	●	●	●	●	●	●	●			
	C			●	●	●		●		●	●	●	●				
	G			●	●	●				●	●	●	●				
	CR			●				●			●	●	●				
	S			●							●	●	●				
	SR			●							●	●	●				
	H										●	●					
	HR										●	●					
	K~K4											●	●		●	●	●
	K~K3R											●	●		●	●	●
	F4													●			
	F2													●			
	F2R													●			
	Q	●	●						●								
	Q2								●					●			
Q2R								●					●				

\*For information about other couplings, contact us. For information about adapters, refer to pages 64 and 65.

# Hose Summary

HOSE			HOSE																		
Series Inner Diameter			Standard Resin Hoses					Special Application Resin Hoses					Ultra-High Pressure Resin Hoses								
			PASSTAGE LINE					For machine tools	For paint sprays	For cleaning	For jacks	For steam piping	BRIDGESTONE SELFIT		BRIDGESTONE PRIMOLINE						
inch	mm	Code	Type	KF	KG	SPL	KA	KB	AG10	PS	WSH	JC70	SF	SPL	KF	JAT	JAM	JAL	JKY	JAK	
1/8	3.2	02	Maximum working pressure MPa				19.5							20.5							
3/16	4.8	03				14.0	15.0	25.5			31.0		68.5				294.0	245.0	196.0		
1/4	6.3	04			20.5		14.0	14.5	22.0	10.5	27.5	14.0		2.0	14.5	20.5			147.0	68.5	98.0
5/16	7.9	05					12.0	20.5			24.5							245.0	127.5		68.5
3/8	9.5	06			17.0	20.5	14.0	10.5	17.0	10.5		14.0		2.0	14.5	16.0			117.5		68.5
1/2	12.7	08			14.0	20.5	10.5	10.5	16.0	10.5				2.0	10.5	14.0			98.0		68.5
5/8	15.9	10												2.0					88.0		
3/4	19.0	12			9.0			5.0	9.5										73.5		
7/8	22.2	14																			
1	25.4	16							7.5										68.5		
1-1/4	31.8	20																			
1-1/2	38.1	24																			
2	50.8	32																			
2-1/2	63.5	40																			
3	76.2	48																			
Relevant page				50~51					51					54~56			60~62				
Minimum burst pressure (MPa)				4x max. working pressure					4x max. working pressure	About 3x max. working pressure	3x max. working pressure	2x max. working pressure			4x max. working pressure	About 2x max. working pressure					
Fluid temperature (°C)			-40 to +100					+40 to +93	-20 to +80	0 to +80	-40 to +70	+4 to +220	-30 to +80	-30 to +100	-40 to +50 (oil), 0 to +50 (water)			-40 to +80			
Recommended ambient temperature (°C)			-40 to +70					-40 to +70	-20 to +40	0 to +70	-40 to +70		-30 to +70	-40 to +50 (oil), 0 to +50 (water)			-40 to +70				
Compatible fluid			Mineral hydraulic oil					Mineral hydraulic oil	Organic solvent paint	Water	Mineral hydraulic oil	Steam	Mineral hydraulic oil	Water/mineral hydraulic oil	Mineral hydraulic oil	Water/mineral hydraulic oil	Mineral hydraulic oil				
Uses and features			Ordinary hydraulic piping		Ordinary hydraulic piping		Machine tools, injury protection	Paint sprays, antistatic treatment	Cleaning, shock absorption	Ultra high pressure hydraulic tools	Steam piping	Crimping machine not required	Water jet devices, jacks, high-pressure cleaning tools		Jacks						
Warranty period			Period	1 year					1 year	6 months	1 year			1 year							
			No. of times used	150,000	200,000	150,000		150,000	25,000	—	25,000	100,000	150,000		5,000	10,000	15,000	100,000	200,000		

\*Warranty is effective until the predetermined usage period expires or the impulse cycle count reaches the predetermined value, whichever occurs first. (The impulse cycle count refers to the number of times the hose has been pressurized under the specified hose usage conditions.)

## COUPLING

\*For information about other couplings, contact us. For information about adapters, refer to pages 64 and 65.

Hose type		KF	KG	SPL	KA	KB	AG10	PS	WSH	JC70	SF	SPL	KF	JAT	JAM	JAL	JKY	JAK	
Coupling thread type	Relevant page	27~33					34~46												
	R	●	●	●	●	●	●	●	●	●	●	●	●				●	●	●
	F	●	●	●	●	●	●	●	●	●	●	●	●						
	C	●	●	●	●	●	●	●	●	●	●	●	●						
	G																●		
	CR	●	●		●	●			●	●									
	S																		
	SR																		
	H																		
	HR																		
	K·K2																		
	K~K4																		
	K~K3R																		
	F4																		
	F2																		
	F2R																		
	Q																	●	●
Q2																			
Q2R																			

# Hoses and Couplings

This catalog shows the series of UNICRIMP-cripped couplings for UC28. If you use other model, check the standards shown in your torque-tightening standard table. If you have any questions, contact us.

Standard Pressure Rubber Hoses			
Hose catalog number		Applicable coupling series	
Series	Size	Factor -cripped	UNICRIMP -cripped
OKE	04	LS	LS
	06		
	08		
	10		
	12		
PA01	04	AS	AS/UL
	06		
	08		
	10		
PA03	04	AS	AS/UL
	06		
	08		
	10		
	12		
	16		
	20		
PA07	04	UB	UB
	06		
	08		
	10		
	12		
PA10	04	UB	UB
	06		
	08		
	10		
	12		
	16		
	20		
PA14	04	UB	UB
	06		
	08		
	10		
	12		
	16		
	20		
PA17	04	UB	UB
	06		
	08		
	10		
	12		
PA21	04	UB	UB
	06		
	08		
	10		
	12		
	16		
	20		
PA28	04	UB	UB
	06		
	08		
	10		
	12		
PA35	04	UB	UB
	06		
	08		
	10		
	12		
	16		
	20		
PF07	04	UL/UZ	UL/UZ
	06		
	08		
PF14	04	UB	UB
	06		
	08		
PF17	04	UB	UB
	06		
	08		
PF21	04	UB	UB
	06		
	08		
	10		
	12		
PFW	04	UB	UB
	06		
	08		
PFH	04	UB	UB
	06		
	08		

High Durable Rubber Hoses			
Hose catalog number		Applicable coupling series	
Series	Size	Factor -cripped	UNICRIMP -cripped
HQ35	08	UB	UB
	10		
	12		
	16		
	20		
CQ36	04	UB	UB
	06		
	08		
	10		
	12		
CQ38	16	UB(CX)	-
	20		
	24		
	32		
	40		
SQ28	08	UB	-
	10		
	12		
	16		
	20		
EQ17	08	UB	UB
	10		
	12		
	16		
	20		
EQ21	08	UB	UB
	10		
	12		
	16		
	20		
EQ25	08	UB	UB
	10		
	12		
	16		
	20		
EQ28	08	UB	UB
	10		
	12		
	16		
	20		
EQ31	08	UB	UB
	10		
	12		
	16		
	20		

Special Application Rubber Hoses				
Hose catalog number		Applicable coupling series		
Series	Size	Factor -cripped	UNICRIMP -cripped	Push-on hoses
JW70	04	ZP	ZP	-
	06	KH	-	-
	08	UB	UB	-
JWK	04	EK	-	-
	06			
	08			
VW	16	UT	UT	-
	20	LC	LC	-
	24	HW	HW	-
	32	HW	HW	-
WA14	04	UL	UL	-
	06			
	08			
WAR	04	UL	UL	-
	06			
	08			
SA	08	SK	-	-
	12			
	16			
HM	12	UN	-	-
	16			
	20			
ACT	04	-	-	AT
	06			
	08			
WH21	04	UF	GA(UL)	-
	06	UZ	UZ	-
	08	UB	UB	-
	12	GB	GB	-
	16	UB	UB	-
WE21	20	KN	-	-
	24			
	32			
	40			
	48			
	56			
	64			
WE28	04	UB	UB	-
	06			
	08			
	12			
	16			
	20			
	24			
PA03-DA	04	AS	UL	-
	06			
	08			
	12			
	16			
	20			
	24			
JBT	40	EC	-	-
	48			
	56			
JBF	40	DX	-	-
	48			
	56			
JBS	40	EX	-	-
	48			
	56			

Standard Resin Hoses			
Hose catalog number		Applicable coupling series	
Series	Size	Factor -cripped	UNICRIMP -cripped
KF	04	JY	SY
	06		
	08		
	12		
KG	06	SY	SY
	08		
SPL	03	CG	SG
	04		
	06		
	08		
KA	02	SY	SY
	03		
	04		
	05		
	06		
	08		
KB	03	JY	CY
	04		
	05		
	06		
	08		
	12		

Special Application Resin Hoses			
Hose catalog number		Applicable coupling series	
Series	Size	Factor -cripped	UNICRIMP -cripped
AG10	04	JG	SG
	06		
	08		
PS	03	CY	-
	04		
	05		
WSH	04	JY	SY
	06		
JC70	03	CVW	-
	04		
SF	04	JG	SG
	06		
	08		
	10		

Ultra-High Pressure Resin Hoses			
Hose catalog number		Applicable coupling series	
Series	Size	Factor -cripped	UNICRIMP -cripped
JAT	03	BN	-
JAM	03	BX	-
	05		
JAL	03	AL	-
	04		
	05		
	06		
	08		
	10		
JKY	04	UY	-
	05		
	06		
	08		
JAK	04	AK	-
	05		
	06		

# OKE Series For Low Pressure

- Compatible Fluid / Mineral Oil, Water
- Inner Tube / Oil Resistant Synthetic Rubber
- Outer Cover / Weather Resistant Synthetic Rubber
- Temperature Range: fluid / -40°C to 100°C(Oil) / 0°C to 50°C(Water)  
-40°F to 212°F(Oil) / 32°F to 122°F(Water)
- Temperature Range : ambient / -40°C to 70°C(-40°F to 158°F)

**OKE**

Maximum Working Pressure  
**1.5MPa  
200PSI**

Catalog Number	I.D.		O.D.		Max.W.P.		Min.B.P.		Min.B.R.		Weight		Reinforcement	Compatible coupling/relevant page	
	inch	mm	inch	mm	psi	MPa	psi	MPa	inch	mm	lbs/ft	g/m		Factory-assembled	UNICRIMP-crimped
OKE04	1/4	6.6	0.50	12.7	200	1.5	600	4.5	2.56	65	0.09	130	2C	LS/27	LS/27
OKE06	3/8	9.7	0.63	15.9					2.95	75	0.12	170			
OKE08	1/2	13.0	0.78	19.8					3.94	100	0.16	240			
OKE10	5/8	16.2	0.93	23.5					4.92	125	0.21	310		UT/27	UT/27
OKE12	3/4	19.3	1.09	27.7					5.91	150	0.29	430			
OKE16	1	25.7	1.44	36.5					7.87	200	0.48	720		4C	

\*These hoses cannot be used under surge (shock) pressure. If the hose will be subjected to surge (shock) pressure, replace it with a PASCALART hose (PA).  
 \*Hoses suitable for use at high temperatures (120°C and 150°C) are also available. For details, refer to the Lace-up Rubber Hose Catalog.  
 We recommend using water-glycol with couplings on which the wetted parts only are nickel chrome plated (the catalog numbers of these couplings end with X103).  
**Warning** Do not use high water base fluid (HWBF) with the hoses listed above. Doing so could cause the hoses to burst or fluid to leak. Severe personal injury or death may result if these instructions are not followed.

# PASCALART

- JIS Standard
- JIS K6349-3(high-pressure rubber hose)
- JIS B8360(high-pressure rubber hose assembly)

- Compatible Fluid  
Mineral Oil
- Inner Tube  
Oil Resistant Synthetic Rubber
- Outer Cover  
Weather Resistant Synthetic Rubber
- Temperature Range : fluid  
-40°C to +100°C (-40°F to +212°F)
- Temperature Range : ambient  
-40°C to +70°C (-40°F to +158°F)



## 1 LONGER HOSE LIFE

PASCALART series hose provides a longer service life and a greater fatigue resistance than conventional hose. PASCALART series hose guarantees a service life of 400,000 impulse cycles conforming to JIS heavy duty application standard B8360. Conventional hose assures a service life of only 100,000 to 200,000 impulse cycles.

### Hose Life Comparison

<b>PASCALART</b>	400,000 impulse cycles (JIS waveform)
SAE100R2	200,000 impulse cycles (SAE waveform)
SAE100R1	150,000 impulse cycles (SAE waveform)

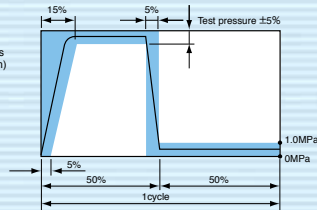

## 2 SMALLER BENDING RADIUS

PASCALART series hose minimum bending radius is 2/3 of the JIS K6349 standard, which results in shorter hydraulic hose assemblies, and more compact hydraulic circuits.

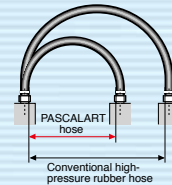

## 3 BROAD RANGE

PASCALART series hose is classified into 9 different working pressure categories. This broad range of working pressures, makes it easy to select the right hose for any given hydraulic circuit pressure.

**PA01**

Maximum Working Pressure  
**1.5MPa  
200PSI**

Catalog Number	I.D.		O.D.		Max.W.P.		Min.B.P.		Min.B.R.		Weight		Reinforcement	Compatible coupling/relevant page	
	inch	mm	inch	mm	psi	MPa	psi	MPa	inch	mm	lbs/ft	g/m		Factory-assembled	UNICRIMP-crimped
PA0104*	1/4	6.3	0.55	14.0	200	1.5	870	6.0	2.17	55	0.33	150	4C	AS/27	UL/30
PA0106*	3/8	9.5	0.69	17.4					2.56	65	0.53	240			
PA0108*	1/2	12.7	0.83	21.2					3.54	90	0.62	280			

We recommend using water-glycol with couplings on which the wetted parts only are nickel chrome plated (the catalog numbers of these couplings end with X103).  
 \*For factory-assembled hoses with stainless steel fittings, select the UL series hoses.  
**Warning** Do not use high water base fluid (HWBF) with the hoses listed above. Doing so could cause the hoses to burst or fluid to leak. Severe personal injury or death may result if these instructions are not followed.

### Reinforcing



## PA03

Maximum Working Pressure

**3.5MPa  
500PSI**

Catalog Number	I.D.		O.D.		Max.W.P.		Min.B.P.		Min.B.R.		Weight		Reinforcement	Compatible coupling/relevant page	
	inch	mm	inch	mm	psi	MPa	psi	MPa	inch	mm	lbs/ft	g/m		Factory-assembled	UNICRIMP-cripped
	PA0304*	1/4	6.3	0.55	14.0	500	3.5	2,000	14.0	2.17	55	0.10		170	4C
PA0306*	3/8	9.5	0.69	17.4	2.56					65	0.14	220	UL/230		
PA0308*	1/2	12.7	0.83	21.2	3.54					90	0.19	290			
PA0310	5/8	15.9	0.93	23.5	4.33					110	0.20	310	2C	UT/27	UL/30
PA0312	3/4	19.0	1.24	31.4	5.31					135	0.39	620	4C		
PA0316	1	25.4	1.48	37.5	6.69					170	0.49	800	1W		
PA0320	1-1/4	31.8	1.64	41.7	7.87					200	0.77	950		UT/27	
PA0324	1-1/2	38.1	1.90	48.3	9.84					250	0.90	1,170	LC/27	LC/27	

We recommend using water-glycol with couplings on which the wetted parts only are nickel chrome plated (the catalog numbers of these couplings end with X103). \*Factory-assembled hoses with stainless steel fittings are the UL series hoses.



Do not use high water base fluid (HWBF) with the hoses listed above. Do not use water-glycol with either PA0320 or PA0324. Failure to observe these instructions could cause the hoses to burst or fluid to leak. Severe personal injury or death may result if these instructions are not followed.

## PA07

Maximum Working Pressure

**7.0MPa  
1,000PSI**

Catalog Number	I.D.		O.D.		Max.W.P.		Min.B.P.		Min.B.R.		Weight		Reinforcement	Compatible coupling/relevant page	
	inch	mm	inch	mm	psi	MPa	psi	MPa	inch	mm	lbs/ft	g/m		Factory-assembled	UNICRIMP-cripped
	PA0704*	1/4	6.3	0.53	13.5	1,000	7.0	4,000	28.0	2.17	55	0.15		220	1W
PA0706*	3/8	9.5	0.66	16.7	2.95					75	0.22	330	UB/34		
PA0708*	1/2	12.7	0.76	19.4	3.15					80	0.25	380		UB/34	
PA0710*	5/8	15.9	0.94	23.8	4.33					110	0.34	510	UB/34		
PA0712*	3/4	19.0	1.05	26.6	5.12					130	0.40	600		2W	
PA0716*	1	25.4	1.32	33.5	6.89					175	0.57	850	UZ/34		UZ/34
PA0720	1-1/4	31.8	1.71	43.5	8.66					220	1.07	1,610		HW/41	
PA0724	1-1/2	38.1	1.98	50.2	10.63					270	1.27	1,910	2W		
PA0732	2	50.8	2.49	63.2	13.78	350	1.66	2,490	4S						

We recommend using water-glycol with couplings on which the wetted parts only are nickel chrome plated (the catalog numbers of these couplings end with X103). \*Factory-assembled hoses with stainless steel fittings are the UL and UX series hoses.



Do not use high water base fluid (HWBF) with the hoses listed above. Do not use water-glycol with either PA0720 or PA0724 or PA0732. Failure to observe these instructions could cause the hoses to burst or fluid to leak. Severe personal injury or death may result if these instructions are not followed.

## PA10

Maximum Working Pressure

**10.5MPa  
1,500PSI**

Catalog Number	I.D.		O.D.		Max.W.P.		Min.B.P.		Min.B.R.		Weight		Reinforcement	Compatible coupling/relevant page	
	inch	mm	inch	mm	psi	MPa	psi	MPa	inch	mm	lbs/ft	g/m		Factory-assembled	UNICRIMP-cripped
	PA1004*	1/4	6.3	0.53	13.5	1,500	10.5	6,000	42.0	2.17	55	0.15		230	1W
PA1006*	3/8	9.5	0.66	16.7	2.95					75	0.23	340	UB/34		
PA1008*	1/2	12.7	0.76	19.4	3.15					80	0.26	390		UB/34	
PA1010*	5/8	15.9	0.94	23.8	4.33					110	0.35	530	UB/34		
PA1012*	3/4	19.0	1.05	26.6	5.12					130	0.41	610		2W	
PA1016*	1	25.4	1.32	33.5	6.89					175	0.57	860	UZ/34		UZ/34
PA1020	1-1/4	31.8	1.71	43.5	8.66					220	1.07	1,610		HW/41	
PA1024	1-1/2	38.1	1.98	50.2	10.63					270	1.27	1,910	2W		
PA1032	2	50.8	2.60	66.0	14.57	370	2.77	4,150	4S						

We recommend using water-glycol with couplings on which the wetted parts only are nickel chrome plated (the catalog numbers of these couplings end with X103). \*Factory-assembled hoses with stainless steel fittings are the UL and UX series hoses.



Do not use high water base fluid (HWBF) with the hoses listed above. Do not use water-glycol with PA1020, PA1024, or PA1032. Failure to observe these instructions could cause the hoses to burst or fluid to leak. Severe personal injury or death may result if these instructions are not followed.

## PA14

Maximum Working Pressure

**14.0MPa  
2,000PSI**

Catalog Number	I.D.		O.D.		Max.W.P.		Min.B.P.		Min.B.R.		Weight		Reinforcement	Compatible coupling/relevant page	
	inch	mm	inch	mm	psi	MPa	psi	MPa	inch	mm	lbs/ft	g/m		Factory-assembled	UNICRIMP-cripped
	PA1404*	1/4	6.3	0.53	13.5	2,000	14.0	8,000	56.0	2.17	55	0.16		240	1W
PA1406*	3/8	9.5	0.66	16.7	2.95					75	0.23	350	UB/34		
PA1408*	1/2	12.7	0.76	19.4	3.54					90	0.27	400		UB/34	
PA1410*	5/8	15.9	1.00	25.4	4.72					120	0.50	750	2W		
PA1412*	3/4	19.0	1.15	29.3	5.51					140	0.63	940		UB/34	
PA1416*	1	25.4	1.41	35.8	7.09					180	0.82	1,230	UZ/34		UZ/34
PA1420	1-1/4	31.8	1.71	43.5	9.45					240	1.07	1,610		4S	
PA1424	1-1/2	38.1	2.07	52.7	11.02					280	2.04	3,060	4S		
PA1432	2	50.8	2.60	66.0	14.57	370	2.77	4,150	4S						

We recommend using water-glycol with couplings on which the wetted parts only are nickel chrome plated (the catalog numbers of these couplings end with X103). \*Factory-assembled hoses with stainless steel fittings are the UL and UX series hoses.



Do not use high water base fluid (HWBF) with the hoses listed above. Do not use water-glycol with PA1420, PA1424, or PA1432. Failure to observe these instructions could cause the hoses to burst or fluid to leak. Severe personal injury or death may result if these instructions are not followed.

**4C**

4 fabric spiral

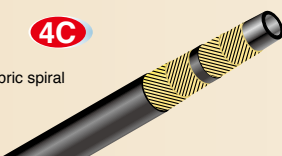

**4S**

4 spiral wires



# PA series

## PA17

Maximum Working Pressure

**17.0MPa**  
**2,500PSI**

Catalog Number	I.D.		O.D.		Max.W.P.		Min.B.P.		Min.B.R.		Weight		Reinforcement	Compatible coupling/relevant page	
	inch	mm	inch	mm	psi	MPa	psi	MPa	inch	mm	lbs/ft	g/m		Factory-assembled	UNCrimp-crimped
	PA1704*	1/4	6.3	0.53	13.5	2,500	17.0	10,000	68.0	2.36	60	0.16		240	1W
PA1706*	3/8	9.5	0.66	16.7	3.15					80	0.24	360	UB/34	UB/34	
PA1708	1/2	12.7	0.76	19.4	3.54					90	0.28	420	UZ/34		
PA1710	5/8	15.9	1.00	25.4	4.72					120	0.51	770	2W	UB/34	
PA1712	3/4	19.0	1.15	29.3	5.51					140	0.63	950			
PA1716	1	25.4	1.41	35.8	7.28					185	0.87	1,300			

\*For factory-assembled hoses with stainless steel fittings, select the UL series hoses.

## PA21

Maximum Working Pressure

**20.5MPa**  
**3,000PSI**

Catalog Number	I.D.		O.D.		Max.W.P.		Min.B.P.		Min.B.R.		Weight		Reinforcement	Compatible coupling/relevant page	
	inch	mm	inch	mm	psi	MPa	psi	MPa	inch	mm	lbs/ft	g/m		Factory-assembled	UNCrimp-crimped
	PA2104	1/4	6.3	0.53	13.5	3,000	20.5	12,000	82.0	2.76	70	0.17		250	1W
PA2106	3/8	9.5	0.71	18.0	3.54					90	0.31	470	UB/34	UB/34	
PA2108	1/2	12.7	0.87	22.2	4.33					110	0.43	650	2W		UZ/34
PA2110	5/8	15.9	1.00	25.4	5.51					140	0.51	770		UB/34	
PA2112	3/4	19.0	1.15	29.3	6.69					170	0.64	960			UB/34
PA2116	1	25.4	1.41	35.8	8.27					210	0.87	1,300	4S	UZ/34	UZ/34
PA2120	1-1/4	31.8	1.78	45.2	10.24					260	1.57	2,360			
PA2124	1-1/2	38.1	2.07	52.7	12.20					310	2.04	3,060			
PA2132	2	50.8	2.60	66.0	16.93					430	2.77	4,150	HW/40	HW/40	

## PA28

Maximum Working Pressure

**27.5MPa**  
**4,000PSI**

Catalog Number	I.D.		O.D.		Max.W.P.		Min.B.P.		Min.B.R.		Weight		Reinforcement	Compatible coupling/relevant page	
	inch	mm	inch	mm	psi	MPa	psi	MPa	inch	mm	lbs/ft	g/m		Factory-assembled	UNCrimp-crimped
	PA2804	1/4	6.3	0.59	15.1	4,000	27.5	16,000	110.0	2.76	70	0.25		380	2W
PA2806	3/8	9.5	0.75	19.1	3.94					100	0.36	540	UB/34	UB/34	
PA2808	1/2	12.7	0.87	22.2	4.33					110	0.52	780			4S
PA2810	5/8	15.9	1.04	26.4	5.51					140	0.67	1,000	UZ/34		
PA2812	3/4	19.0	1.14	29.0	6.69					170	0.75	1,130		UZ/34	
PA2816	1	25.4	1.41	35.9	8.66					220	1.17	1,750	6S	KN/41	—
PA2820	1-1/4	31.8	1.80	45.6	11.02					280	1.74	2,610			
PA2824	1-1/2	38.1	2.20	55.9	12.60					320	2.93	4,390			
PA2832	2	50.8	2.95	75.0	16.93					430	5.27	7,900	KD/41	—	

## PA35

Maximum Working Pressure

**34.5MPa**  
**5,000PSI**

Catalog Number	I.D.		O.D.		Max.W.P.		Min.B.P.		Min.B.R.		Weight		Reinforcement	Compatible coupling/relevant page	
	inch	mm	inch	mm	psi	MPa	psi	MPa	inch	mm	lbs/ft	g/m		Factory-assembled	UNCrimp-crimped
	PA3504	1/4	6.3	0.59	15.1	5,000	34.5	20,000	138.0	3.15	80	0.26		390	2W
PA3506	3/8	9.5	0.75	19.1	4.33					110	0.37	550	UB/34	UB/34	
PA3508	1/2	12.7	0.87	22.2	5.91					150	0.53	800			4S
PA3510	5/8	15.9	1.04	26.4	6.69					170	0.67	1,000	UZ/34		
PA3512	3/4	19.0	1.14	29.0	8.66					220	0.75	1,130		UZ/34	
PA3516	1	25.4	1.44	36.6	11.02					280	1.33	2,000	6S	KN/41	—
PA3520	1-1/4	31.8	1.93	49.0	12.99					330	2.57	3,850			
PA3524	1-1/2	38.1	2.20	55.9	14.96					380	2.96	4,440			
PA3532	2	50.8	2.95	75.0	19.69					500	5.33	8,000	KD/41	—	

Reinforcing

**1W**

1 wire braid

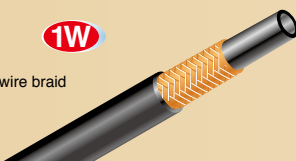

**2W**

2 wire braids



**4S**

4 spiral wires





# PASCALART-f

Based on PASCALART

More flexible

Smaller bending radius

- Compatible Fluid / Mineral Oil
- Inner Tube / Synthetic Rubber
- Outer Cover / Synthetic Rubber
- Temperature Range : fluid / -40°C to + 100°C  
-40°F to + 212°F
- Temperature Range : ambient / -40°C to +70°C  
-40 °F to +158°F

## PF07

Maximum Working Pressure

**7.0MPa**  
**1,000PSI**

Catalog Number	I.D.		O.D.		Max.W.P.		Min.B.P.		Min.B.R.		Weight		Reinforcement	Compatible coupling/relevant page	
	inch	mm	inch	mm	psi	MPa	psi	MPa	inch	mm	lbs/ft	g/m		Factory-assembled	UNICRIMP-cripped
	PF0704*	1/4	6.3	0.47	11.9	1,000	7.0	4,000	28.0	1.57	40	0.09		140	1W
PF0706*	3/8	9.5	0.61	15.5	1.97					50	0.15	220	UB/34	UB/34	
PF0708*	1/2	12.7	0.73	18.5	2.56					65	0.21	320	UZ/34		

\*For factory-assembled hoses with stainless steel fittings, select the UL series hoses.

## PF14

Maximum Working Pressure

**14.0MPa**  
**2,000PSI**

Catalog Number	I.D.		O.D.		Max.W.P.		Min.B.P.		Min.B.R.		Weight		Reinforcement	Compatible coupling/relevant page	
	inch	mm	inch	mm	psi	MPa	psi	MPa	inch	mm	lbs/ft	g/m		Factory-assembled	UNICRIMP-cripped
	PF1404*	1/4	6.3	0.47	11.9	2,000	14.0	8,000	56.0	1.57	40	0.10		150	1W
PF1406*	3/8	9.5	0.61	15.5	1.97					50	0.15	230	UB/34	UB/34	
PF1408*	1/2	12.7	0.75	19.0	2.36					60	0.23	350	UZ/34		

\*For factory-assembled hoses with stainless steel fittings, select the UL series hoses.

## PF17

Maximum Working Pressure

**17.0MPa**  
**2,500PSI**

Catalog Number	I.D.		O.D.		Max.W.P.		Min.B.P.		Min.B.R.		Weight		Reinforcement	Compatible coupling/relevant page	
	inch	mm	inch	mm	psi	MPa	psi	MPa	inch	mm	lbs/ft	g/m		Factory-assembled	UNICRIMP-cripped
	PF1704*	1/4	6.3	0.50	12.6	2,500	17.0	10,000	68.0	1.77	45	0.13		190	1W
PF1706*	3/8	9.5	0.66	16.7	2.36					60	0.22	330	UB/34	UB/34	
PF1708*	1/2	12.7	0.80	20.2	3.15					80	0.33	500	2W		

\*For factory-assembled hoses with stainless steel fittings, select the UL series hoses.

## PF21

Maximum Working Pressure

**20.5MPa**  
**3,000PSI**

Catalog Number	I.D.		O.D.		Max.W.P.		Min.B.P.		Min.B.R.		Weight		Reinforcement	Compatible coupling/relevant page		
	inch	mm	inch	mm	psi	MPa	psi	MPa	inch	mm	lbs/ft	g/m		Factory-assembled	UNICRIMP-cripped	
	PF2104*	1/4	6.3	0.50	12.6	3,000	20.5	12,000	82.0	1.97	50	0.13		200	1W	UZ/34
PF2106	3/8	9.5	0.68	17.2	2.56					65	0.28	420	UB/34	UB/34		
PF2108	1/2	12.7	0.80	20.2	3.35					85	0.35	530	UZ/34			
PF2110	5/8	15.9	0.98	24.9	3.94					100	0.47	710	2W			
PF2112	3/4	19.0	1.13	28.7	4.72					120	0.61	910				UB/34
PF2116	1	25.4	1.41	35.8	7.09					190	0.83	1,250				

\*For factory-assembled hoses with stainless steel fittings, select the UL series hoses.

## PFW

Maximum Working Pressure

**24.5MPa**  
**3,500PSI**

Catalog Number	I.D.		O.D.		Max.W.P.		Min.B.P.		Min.B.R.		Weight		Reinforcement	Compatible coupling/relevant page	
	inch	mm	inch	mm	psi	MPa	psi	MPa	inch	mm	lbs/ft	g/m		Factory-assembled	UNICRIMP-cripped
	PFW04	1/4	6.3	0.53	13.4	3,500	24.5	14,000	98.0	1.97	50	0.19		290	2W
PFW06	3/8	9.5	0.68	17.2	2.76					70	0.29	430	UB/34		
PFW08	1/2	12.7	0.80	20.2	3.54					90	0.36	540	UZ/34		

## PFH

Maximum Working Pressure

**27.5MPa**  
**4,000PSI**

Catalog Number	I.D.		O.D.		Max.W.P.		Min.B.P.		Min.B.R.		Weight		Reinforcement	Compatible coupling/relevant page	
	inch	mm	inch	mm	psi	MPa	psi	MPa	inch	mm	lbs/ft	g/m		Factory-assembled	UNICRIMP-cripped
	PFH04	1/4	6.3	0.53	13.4	4,000	27.5	16,000	110.0	1.97	50	0.20		300	2W
PFH06	3/8	9.5	0.68	17.2	2.76					70	0.30	450	UB/34	UB/34	
PFH08	1/2	12.7	0.80	20.2	3.54					90	0.37	550	UZ/34		



6 spiral wires



# HQ35 Series

## Impulse cycle 1,200,000

- Compatible Fluid / Mineral Oil
- Inner Tube / Synthetic Rubber
- Outer Cover / Synthetic Rubber
- Temperature Range : fluid / -40°C to 100°C(-40°F to 212°F)
- Temperature Range : ambient / -40°C to 70°C(-40 °F to 158°F)

HQ35															
Catalog Number	I.D.		O.D.		Max. W.P.		Min. B.P.		Min. B.R.		Weight		Reinforcement	Compatible coupling/relevant page	
	inch	mm	inch	mm	psi	MPa	psi	MPa	inch	mm	lbs/ft	g/m		Factory-assembled	UNCRIMP-crimped
HQ3508	1/2	12.7	0.87	22.2	5,000	34.5	20,000	138.0	4.72	120	0.50	750	4S	UB/34	UB/34
HQ3510	5/8	15.9	1.04	26.4					6.30	160	0.66	990			
HQ3512	3/4	19.0	1.14	29.0					7.87	200	0.72	1,080			
HQ3516	1	25.4	1.44	36.6					9.45	240	1.30	1,950			
HQ3520	1-1/4	31.8	1.92	48.7					12.99	330	2.49	3,730		6S	UB/34

Maximum Working Pressure  
**34.5MPa**  
**5,000PSI**

# CQ Series Impulse cycle 1,000,000

## MSHA Approved

- Compatible Fluid / Mineral Oil
- Inner Tube / Oil Resistant Synthetic Rubber
- Outer Cover / Weather Resistant Synthetic Rubber
- Temperature Range : fluid / -40°C to +100°C(-40°F to +212°F)(CQ36)  
fluid -40°C to +120°C(-40°F to +248°F)(CQ38)
- Temperature Range : ambient / -40°C to 70°C(-40 °F to 158°F)

CQ36/38															
Catalog Number	I.D.		O.D.		Max. W.P.		Min. B.P.		Min. B.R.		Weight		Reinforcement	Compatible coupling/relevant page	
	inch	mm	inch	mm	psi	MPa	psi	MPa	inch	mm	lbs/ft	g/m		Factory-assembled	UNCRIMP-crimped
CQ3604	1/4	6.3	0.59	15.1	5,200	36.0	20,800	144.0	3.15	80	0.26	380	2W	UZ/34	UZ/34
CQ3606	3/8	9.5	0.76	19.2					4.33	110	0.38	570			
CQ3608	1/2	12.7	0.87	22.2					5.51	140	0.50	750	4S	UB/34	UB/34
CQ3610	5/8	15.9	1.04	26.4					5.91	150	0.67	1000			
CQ3812	3/4	19.0	1.19	30.1	8.27	210	0.94	1400	UB(CX)/34	-					
CQ3816	1	25.4	1.44	36.6	5,500	38.0	22,000	152.0	10.24		260	1.31	1950	6S	UB/34
CQ3820	1-1/4	31.8	1.87	47.4					12.99	330	2.42	3600			

Maximum Working Pressure  
**36.0~38.0MPa**  
**5,200~5,500PSI**

# SQ28 Series

## Ultra High Abrasion resistant hose

- Compatible Fluid / Mineral Oil
- Inner Tube / Oil Resistant Synthetic Rubber
- Outer Cover / Weather Resistant Synthetic Rubber with Ultra High Molecular Weight Polyethylene
- Temperature Range : fluid / -40°C to +100°C(-40°F to +212°F)
- Temperature Range : ambient / -40°C to +70°C(-40°F to +158°F)

SQ28															
Catalog Number	I.D.		O.D.		Max. W.P.		Min. B.P.		Min. B.R.		Weight		Reinforcement	Compatible coupling/relevant page	
	inch	mm	inch	mm	psi	MPa	psi	MPa	inch	mm	lbs/ft	g/m		Factory-assembled	UNCRIMP-crimped
SQ2808	1/2	12.7	0.89	22.5	4,000	27.5	16,000	110.0	4.72	120	0.52	770	4S	UB/34	-
SQ2810	5/8	15.9	1.05	26.7					5.91	150	0.68	1010			
SQ2812	3/4	19.0	1.15	29.3					7.09	180	0.74	1100			

Maximum Working Pressure  
**27.5MPa**  
**4,000PSI**

### Reinforcing



2 wire braids



4 spiral wires



6 spiral wires



# EPOQU

- Compatible Fluid  
Mineral Oil
- Inner Tube  
Oil Resistant Synthetic Rubber
- Outer Cover  
Weather Resistant Synthetic Rubber
- Temperature Range : fluid  
-40°C to +120°C (-40°F to +248°F)
- Temperature Range : ambient  
-40°C to +70°C (-40°F to +158°F)



## 1 CONTINUOUS SERVICE AT 120°C (248°F)

EPOQU series hose can be used continuously with a hydraulic circuit oil temperature of 120°C(248°F). Conventional hose is only rated for 100°C(212°F)

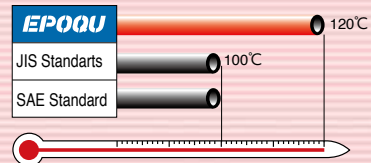

## 2 LONGER HOSE LIFE

EPOQU successfully passes 1,000,000 impulse cycles at 120°C (250°F).

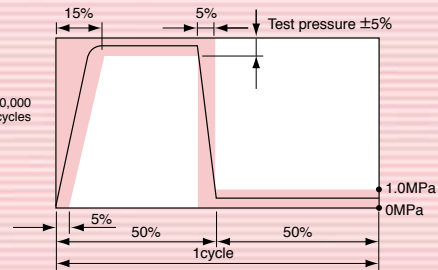
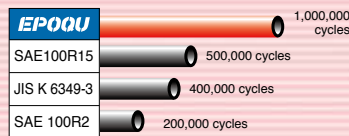

## 3 SMALLER BENDING RADIUS

EPOQU series hose minimum bending radius is 2/3 of the conventional standard, which results in shorter hydraulic hose assembly lengths, and more compact hydraulic circuits.

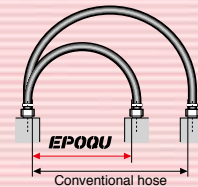

## 4 EASY INSTALLATION

EPOQU is flexible. EPOQU requires just 2/3 of the force necessary to bend the conventional rubber hose to the same bending radius. Thus, EPOQU allows easy and speedy installation.

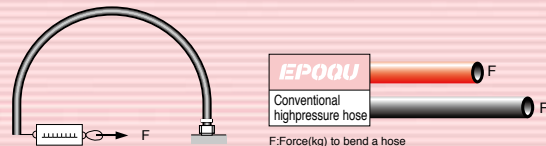

## 5 BROAD RANGE

EPOQU series is classified into 5 categories of different working pressure so that you can select a right hose according to the pressure rating of the pump to be applied.

### EQ17

Maximum Working Pressure

**17.0MPa**  
**2,500PSI**

Catalog Number	I.D.		O.D.		Max.W.P.		Min.B.P.		Min.B.R.		Weight		Reinforcement	Compatible coupling/relevant page	
	inch	mm	inch	mm	psi	MPa	psi	MPa	inch	mm	lbs/ft	g/m		Factory-assembled	UNICRIMP-cripped
EQ1708	1/2	12.7	0.87	22.2	2,500	17.0	12,500	85.0	3.54	90	0.42	630	2W	UZ/34	UB/34
EQ1710	5/8	15.9	1.03	26.2					4.33	110	0.57	860			
EQ1712	3/4	19.0	1.15	29.3					5.51	140	0.66	990			
EQ1716	1	25.4	1.39	35.2					6.30	160	0.95	1,430			
EQ1720	1-1/4	31.8	1.80	45.6					8.27	210	1.71	2,560			
EQ1724	1-1/2	38.1	2.07	52.7	11.02	280	2.05	3,070	4S	HW/40	HW/41				

# Epoqu series

## EQ21

Maximum Working Pressure

**20.5MPa**  
**3,000PSI**

Catalog Number	I.D.		O.D.		Max.W.P.		Min.B.P.		Min.B.R.		Weight		Reinforcement	Compatible coupling/relevant page			
	inch	mm	inch	mm	psi	MPa	psi	MPa	inch	mm	lbs/ft	g/m		Factory-assembled	UNICRIMP-crimped		
	EQ2108	1/2	12.7	0.87	22.2	3,000	20.5	15,000	102.5	3.94	100	0.42		630	2W	UZ/34	UB/34
EQ2110	5/8	15.9	1.03	26.2	5.12					130	0.57	860	4S	UB/34		UZ/34	
EQ2112	3/4	19.0	1.14	29.0	5.51					140	0.75	1,130		UZ/34		UZ/34	
EQ2116	1	25.4	1.39	35.2	7.09					180	0.95	1,430	6S	KN/41	—		
EQ2120	1-1/4	31.8	1.80	45.6	9.06					230	1.71	2,560		UZ/34	UZ/34		
EQ2124	1-1/2	38.1	2.07	52.7	12.20					310	2.05	3,070		HW/40	HW/40		
EQ2132	2	50.8	2.76	70.0	16.93					430	3.87	5,800	6S	KN/41	—		

## EQ25

Maximum Working Pressure

**24.5MPa**  
**3,500PSI**

Catalog Number	I.D.		O.D.		Max.W.P.		Min.B.P.		Min.B.R.		Weight		Reinforcement	Compatible coupling/relevant page		
	inch	mm	inch	mm	psi	MPa	psi	MPa	inch	mm	lbs/ft	g/m		Factory-assembled	UNICRIMP-crimped	
	EQ2508	1/2	12.7	0.87	22.2	3,500	24.5	17,500	122.5	3.94	100	0.52		780	4S	UB/34
EQ2510	5/8	15.9	1.04	26.4	5.12					130	0.67	1,000	6S	UZ/34		UZ/34
EQ2512	3/4	19.0	1.14	29.0	6.30					160	0.75	1,130		KN/41		—
EQ2516	1	25.4	1.41	35.9	7.09					180	1.17	1,750	6S	KN/41	—	
EQ2520	1-1/4	31.8	1.80	45.6	10.24					260	1.71	2,560		UZ/34	UZ/34	
EQ2524	1-1/2	38.1	2.20	55.9	12.60					320	2.89	4,340		6S	KN/41	—

## EQ28

Maximum Working Pressure

**27.5MPa**  
**4,000PSI**

Catalog Number	I.D.		O.D.		Max.W.P.		Min.B.P.		Min.B.R.		Weight		Reinforcement	Compatible coupling/relevant page		
	inch	mm	inch	mm	psi	MPa	psi	MPa	inch	mm	lbs/ft	g/m		Factory-assembled	UNICRIMP-crimped	
	EQ2808	1/2	12.7	0.87	22.2	4,000	27.5	20,000	137.5	3.94	100	0.52		780	4S	UB/34
EQ2810	5/8	15.9	1.04	26.4	5.12					130	0.67	1,000	6S	UZ/34		UZ/34
EQ2812	3/4	19.0	1.14	29.0	6.30					160	0.75	1,130		KN/41		—
EQ2816	1	25.4	1.41	35.9	7.87					200	1.17	1,750	6S	KN/41	—	
EQ2820	1-1/4	31.8	1.91	48.6	11.81					300	2.43	3,640		UZ/34	UZ/34	
EQ2824	1-1/2	38.1	2.20	55.9	14.17					360	2.89	4,340		6S	KN/41	—

## EQ31

Maximum Working Pressure

**31.0MPa**  
**4,500PSI**

Catalog Number	I.D.		O.D.		Max.W.P.		Min.B.P.		Min.B.R.		Weight		Reinforcement	Compatible coupling/relevant page		
	inch	mm	inch	mm	psi	MPa	psi	MPa	inch	mm	lbs/ft	g/m		Factory-assembled	UNICRIMP-crimped	
	EQ3108	1/2	12.7	0.87	22.2	4,500	31.0	22,500	155.0	4.72	120	0.53		800	4S	UB/34
EQ3110	5/8	15.9	1.04	26.4	6.30					160	0.67	1,000	6S	UZ/34		UZ/34
EQ3112	3/4	19.0	1.14	29.0	7.87					200	0.75	1,130		KN/41		—
EQ3116	1	25.4	1.44	36.6	9.45					240	1.33	2,000	6S	KN/41	—	
EQ3120	1-1/4	31.8	1.93	49.0	12.60					320	2.53	3,800		EX/41	—	
EQ3124	1-1/2	38.1	2.20	55.9	15.35					390	3.00	4,500		6S	EX/41	—
EQ3132	2	50.8	2.95	75.0	22.05					560	5.27	7,900	6S	EX/41	—	

Reinforcing

**1W**

1 wire braid

**2W**

2 wire braids

**4S**

4 spiral wires

# SAE series / DIN series

## SAE Series

- Compatible Fluid / Mineral Oil

## DIN Series

- Compatible Fluid / Mineral Oil
- Only Hose Available



Temperature Range	Fluid	Ambient
R1,R2,4SP,4SH	-40°C to +100°C -40°F to +212°F	-40°C to +70°C -40°F to +158°F
R12,R13,R15	-40°C to +121°C -40°F to +250°F	-40°C to +70°C -40°F to +158°F

### R1AT

SAE 100R1

Catalog Number	I.D.		O.D.		Max.W.P.		Min.B.P.		Min.B.R.		Weight		Reinforcement
	inch	mm	inch	mm	psi	MPa	psi	MPa	inch	mm	lbs/ft	g/m	
	<b>R1AT04</b>	1/4	6.3	0.53	13.5	3260	22.5	13040	90.0	3.94	100	0.15	
<b>R1AT06</b>	3/8	9.5	0.69	17.5	2610	18.0	10440	72.0	4.92	125	0.23	340	
<b>R1AT08</b>	1/2	12.7	0.81	20.6	2320	16.0	9280	64.0	7.09	180	0.28	420	
<b>R1AT10</b>	5/8	15.9	0.94	23.8	1880	13.0	7520	52.0	8.07	205	0.34	510	
<b>R1AT12</b>	3/4	19.0	1.09	27.8	1520	10.5	6080	42.0	9.45	240	0.42	630	
<b>R1AT16</b>	1	25.4	1.41	35.8	1260	8.7	5040	34.8	11.81	300	0.65	960	
<b>R1AT20</b>	1-1/4	31.8	1.70	43.2	890	6.2	3560	25.5	16.54	420	0.81	1,210	
<b>R1AT24</b>	1-1/2	38.1	1.98	50.4	720	5.0	2880	20.0	19.69	500	1.03	1,540	
<b>R1AT32</b>	2	50.8	2.53	64.3	580	4.0	2320	16.0	24.80	630	1.30	1,940	

### R2AT

SAE 100R2

Catalog Number	I.D.		O.D.		Max.W.P.		Min.B.P.		Min.B.R.		Weight		Reinforcement
	inch	mm	inch	mm	psi	MPa	psi	MPa	inch	mm	lbs/ft	g/m	
	<b>R2AT04</b>	1/4	6.3	0.59	15.1	5800	40.0	23200	160.0	3.94	100	0.26	
<b>R2AT06</b>	3/8	9.5	0.75	19.1	4780	33.0	19120	132.0	4.92	125	0.36	540	
<b>R2AT08</b>	1/2	12.7	0.87	22.2	3980	27.5	15920	110.0	7.09	180	0.42	630	
<b>R2AT10</b>	5/8	15.9	1.00	25.4	3620	25.0	14480	100.0	8.07	205	0.52	770	
<b>R2AT12</b>	3/4	19.0	1.16	29.4	3110	21.5	12440	86.0	9.45	240	0.62	920	
<b>R2AT16</b>	1	25.4	1.50	38.1	2390	16.5	9560	66.0	11.81	300	0.96	1,430	
<b>R2AT20</b>	1-1/4	31.8	1.89	48.0	1810	12.5	7240	50.0	16.54	420	1.32	1,970	
<b>R2AT24</b>	1-1/2	38.1	2.14	54.4	1300	9.0	5200	36.0	19.69	500	1.51	2,240	
<b>R2AT32</b>	2	50.8	2.64	67.0	1160	8.0	4640	32.0	24.80	630	1.79	2,660	

6S

6 spiral wires



# SAE series / DIN series

## R12A

SAE 100R12

### Construction

- Inner Tube / Synthetic Rubber
- Outer Cover / Synthetic Rubber
- Reinforcement / 4S

Catalog Number	I.D.		O.D.		Max.W.P.		Min.B.P.		Min.B.R.		Weight		Reinforcement
	inch	mm	inch	mm	psi	MPa	psi	MPa	inch	mm	lbs/ft	g/m	
<b>R12A06</b>	3/8	9.5	0.80	20.3	4,000	28.0	16,000	112.0	4.92	125	0.50	750	4S
<b>R12A08</b>	1/2	12.7	0.94	23.8	4,000	28.0	16,000	112.0	7.09	180	0.53	800	
<b>R12A10</b>	5/8	15.9	1.08	27.4	4,000	28.0	16,000	112.0	7.87	200	0.73	1,100	
<b>R12A12</b>	3/4	19.0	1.21	30.7	4,000	28.0	16,000	112.0	9.45	240	0.83	1,250	
<b>R12A16</b>	1	25.4	1.50	38.0	4,000	28.0	16,000	112.0	11.81	300	1.30	1,950	
<b>R12A20</b>	1-1/4	31.8	1.85	47.0	3,000	21.0	12,000	84.0	16.54	420	1.87	2,800	
<b>R12A24</b>	1-1/2	38.1	2.11	53.5	2,500	17.5	10,000	70.0	19.69	500	2.22	3,330	
<b>R12A32</b>	2	50.8	2.63	66.7	2,500	17.5	10,000	70.0	25.20	640	2.93	4,400	

## R13A

SAE 100R13

### Construction

- Inner Tube / Synthetic Rubber
- Outer Cover / Synthetic Rubber
- Reinforcement / 4S(R13A12/R13A16)  
6S(R13A20/R13A24/R13A32)

Catalog Number	I.D.		O.D.		Max.W.P.		Min.B.P.		Min.B.R.		Weight		Reinforcement
	inch	mm	inch	mm	psi	MPa	psi	MPa	inch	mm	lbs/ft	g/m	
<b>R13A12</b>	3/4	19.0	1.26	32.1	5,000	35.0	20,000	137.9	9.45	240	1.07	1,600	4S
<b>R13A16</b>	1	25.4	1.52	38.7	5,000	35.0	20,000	137.9	11.81	300	1.50	2,250	
<b>R13A20</b>	1-1/4	31.8	1.96	49.8	5,000	35.0	20,000	137.9	16.54	420	2.93	4,400	
<b>R13A24</b>	1-1/2	38.1	2.26	57.3	5,000	35.0	20,000	137.9	19.69	500	3.20	4,800	6S
<b>R13A32</b>	2	50.8	2.80	71.1	5,000	35.0	20,000	137.9	25.20	640	4.80	7,200	

## R15A

SAE 100R15

### Construction

- Inner Tube / Synthetic Rubber
- Outer Cover / Synthetic Rubber
- Reinforcement / 4S(R15A06/RA15A08/  
R15A12/R15A16)  
6S(R15A20/R15A24)

Catalog Number	I.D.		O.D.		Max.W.P.		Min.B.P.		Min.B.R.		Weight		Reinforcement
	inch	mm	inch	mm	psi	MPa	psi	MPa	inch	mm	lbs/ft	g/m	
<b>R15A06</b>	3/8	9.5	0.80	20.3	6,000	42.0	24,000	168.0	5.91	150	0.48	720	4S
<b>R15A08</b>	1/2	12.7	0.94	23.8	6,000	42.0	24,000	168.0	7.87	200	0.61	920	
<b>R15A12</b>	3/4	19.0	1.21	30.7	6,000	42.0	24,000	168.0	10.43	265	0.98	1,470	
<b>R15A16</b>	1	25.4	1.52	38.7	6,000	42.0	24,000	168.0	12.99	330	1.45	2,180	
<b>R15A20</b>	1-1/4	31.8	1.96	49.8	6,000	42.0	24,000	168.0	17.52	445	2.59	3,890	
<b>R15A24</b>	1-1/2	38.1	2.26	57.3	6,000	42.0	24,000	168.0	20.87	530	3.17	4,760	6S

## 4SP

DIN 4SP

### Construction

- Inner Tube / Synthetic Rubber
- Outer Cover / Synthetic Rubber
- Reinforcement / 4S

Catalog Number	I.D.		O.D.		Max.W.P.		Min.B.P.		Min.B.R.		Weight		Reinforcement
	inch	mm	inch	mm	psi	MPa	psi	MPa	inch	mm	lbs/ft	g/m	
<b>4SP06</b>	3/8	9.5	0.84	21.4	6,500	44.5	26,000	178.0	7.09	180	0.55	820	4S
<b>4SP08</b>	1/2	12.7	0.97	24.6	6,000	41.5	24,000	166.0	9.06	230	0.63	950	
<b>4SP10</b>	5/8	15.9	1.11	28.2	5,100	35.0	20,400	140.0	9.84	250	0.80	1,200	
<b>4SP12</b>	3/4	19.0	1.27	32.2	5,100	35.0	20,400	140.0	11.81	300	1.07	1,600	
<b>4SP16</b>	1	25.4	1.56	39.7	4,100	28.0	16,400	112.0	13.39	340	1.53	2,300	
<b>4SP20</b>	1-1/4	31.8	2.00	50.8	3,000	21.0	12,000	84.0	18.11	460	2.13	3,200	
<b>4SP24</b>	1-1/2	38.1	2.25	57.2	2,700	18.5	10,800	74.0	22.05	560	2.53	3,800	

## 4SH

DIN 4SH

### Construction

- Inner Tube / Synthetic Rubber
- Outer Cover / Synthetic Rubber
- Reinforcement / 4S

Catalog Number	I.D.		O.D.		Max.W.P.		Min.B.P.		Min.B.R.		Weight		Reinforcement
	inch	mm	inch	mm	psi	MPa	psi	MPa	inch	mm	lbs/ft	g/m	
<b>4SH12</b>	3/4	19.0	1.27	32.2	6,100	42.0	24,400	168.0	11.02	280	1.07	1,600	4S
<b>4SH16</b>	1	25.4	1.52	38.7	5,500	38.0	22,000	152.0	13.39	340	1.50	2,250	
<b>4SH20</b>	1-1/4	31.8	1.79	45.5	4,700	32.5	18,800	130.0	18.11	460	1.73	2,600	
<b>4SH24</b>	1-1/2	38.1	2.11	53.5	4,200	29.0	16,800	116.0	22.05	560	2.13	3,200	
<b>4SH32</b>	2	50.8	2.68	68.1	3,600	25.0	14,400	100.0	27.56	700	3.20	4,800	

Reinforcing

1W

1 wire braid

1B

1 Special synthetic fiber braid

2W

2 wire braids

# Special Application Rubber Hoses

## JW Series For Hydraulic Jack

- Compatible Fluid / Mineral Oil
- Inner Tube / Oil Resistant Synthetic Rubber
- Outer Cover / Weather Resistant Synthetic Rubber
- Temperature Range: fluid / -40°C to 100°C(-40°F to 212°F)
- Temperature Range: ambient / -40°C to 70°C(-40°F to 158°F)

### JW70

Maximum Working Pressure  
**68.5MPa**  
**9,900PSI**

Catalog Number	I.D.		O.D.		Max.W.P.		Min.B.P.		Min.B.R.		Weight		Reinforcement	Compatible coupling/relevant page								
	inch	mm	inch	mm	psi	MPa	psi	MPa	inch	mm	lbs/ft	g/m		Factory-assembled	UNCRIMP-crimped							
JW7004	1/4	6.3	0.66	16.7	9,900	68.5	28,500	196.0	3.54	90	0.30	450	2W	ZP/45	ZP/45							
JW7006	3/8	9.5	0.82	20.8										22,500	154.0	5.51	140	0.43	750	4S	KH/40	—
JW7008	1/2	12.7	0.87	22.2										20,000	138.0	6.69	170	0.55	830	4S	UB/34	UB/34

Note: The types of coupling threads for the JW70 series are designated "R" and "Q." Use a pressure waveform (jack waveform) that can withstand shock pressure.

### JWK

Maximum Working Pressure  
**98.0~137.0MPa**  
**14,200~19,900PSI**

Catalog Number	I.D.		O.D.		Max.W.P.		Min.B.P.		Min.B.R.		Weight		Reinforcement	Compatible coupling/relevant page	
	inch	mm	inch	mm	psi	MPa	psi	MPa	inch	mm	lbs/ft	g/m		Factory-assembled	UNCRIMP-crimped
JWK04	1/4	6.3	0.73	18.6	19,900	137.0	40,000	275.0	3.54	90	0.30	850	4S+1W	EK/45	
JWK06	3/8	9.5	0.97	24.6	14,200	98.0	32,000	219.5	4.72	120	0.43	1,150			
JWK08	1/2	12.7	1.09	27.8											

■ Hoses for jacks also include PrimoLine hoses. (Refer to pages 59 to 63.)

Note: The types of coupling threads for the JWK series hoses are designated "R" and "Q." Use a pressure waveform (jack waveform) that can withstand shock pressure.

## VW Series For Suction Line

- Compatible Fluid / Mineral Oil
- Inner Tube / Oil Resistant Synthetic Rubber
- Outer Cover / Weather Resistant Synthetic Rubber
- Temperature Range: fluid / -40°C to 100°C(-40°C to 212°F)
- Temperature Range: ambient / -40°C to 70°C(-40°C to 158°F)
- Maximum Allowable Suction: -0.08665 Mpa

### VW

Maximum Working Pressure  
**3.0MPa**  
**400PSI**

Catalog Number	I.D.		O.D.		Max.W.P.		Min.B.P.		Min.B.R.		Weight		Reinforcement	Compatible coupling/relevant page					
	inch	mm	inch	mm	psi	MPa	psi	MPa	inch	mm	lbs/ft	g/m		Factory-assembled	UNCRIMP-crimped				
VW16	1	25.4	1.40	35.6	400	3.0	1,600	12.0	5.51	140	0.63	940	1W	UT/27	UT/27				
VW20	1-1/4	31.8	1.64	41.7										7.09	180	0.77	1,150	LC/27	LC/27
VW24	1-1/2	38.1	1.90	48.3										9.06	230	0.90	1,350	HW/40	HW/40
VW32	2	50.8	2.50	63.4										10.63	270	1.53	2,300	2W	HW/40

Check the delivery dates of products marked ▲.

## Rubber Hoses for Water Cleaning

### 1 Lightweight and flexible design

The lightweight and flexible design of the hoses makes them easy to install. (The WA14 series is about 40% lighter and more flexible than the JW series by Bridgestone.)

### 2 Enhanced safety

The hoses offer enhanced safety by absorbing the shock when the fluid supply goes on or off.

- Compatible Fluid / Water
- Inner Tube / Water-resistant synthetic rubber
- Outer Cover / Abrasion-resistant, weather-resistant synthetic rubber
- Temperature Range: fluid / 0°C to 80°C (32°F to 176°F)
- Temperature Range: ambient / 0°C to 70°C (32°F to 158°F)

### WA14

Maximum Working Pressure  
**14.0MPa**  
**2,000PSI**

Catalog Number	I.D.		O.D.		Max.W.P.		Min.B.P.		Min.B.R.		Weight		Reinforcement	Compatible coupling/relevant page			
	inch	mm	inch	mm	psi	MPa	psi	MPa	inch	mm	lbs/ft	g/m		Factory-assembled	UNCRIMP-crimped		
WA1404	1/4	6.3	0.53	13.4	2,000	14.0	5,000	35.0	1.97	50	0.31	140	1B	UL/30	UL/30		
WA1406	3/8	9.5	0.65	16.5										2.76	70	0.44	200
WA1408	1/2	12.7	0.80	20.2										3.15	80	0.55	250

### WAR

Maximum Working Pressure  
**20.5MPa**  
**3,000PSI**

Catalog Number	I.D.		O.D.		Max.W.P.		Min.B.P.		Min.B.R.		Weight		Reinforcement	Compatible coupling/relevant page			
	inch	mm	inch	mm	psi	MPa	psi	MPa	inch	mm	lbs/ft	g/m		Factory-assembled	UNCRIMP-crimped		
WAR04	1/4	6.3	0.53	13.4	3,000	20.5	8,000	51.5	1.97	50	0.31	140	1B	UL/30	UL/30		
WAR06	3/8	9.5	0.65	16.5										2.76	70	0.44	200
WAR08	1/2	12.7	0.78	19.8										2.76	70	0.55	250

⚠ Caution

The reinforcing for the WA14 and WA R series is made from special synthetic fibers. Do not install these hoses in an environment where they are likely to come into contact with sharp objects (as their reinforcing may be cut, causing the hose to burst.) You are recommended to install WJ or WB21 series hoses in the environment above.

4S

4 spiral wires

4S+1W

4 spiral wires +  
1 wire braid

6S

6 spiral wires

# Special Application Rubber Hoses

## SA Series For Steam

For steam piping, use the SF series hoses (shown on page 51). Replacement of the hose may be required after a short usage period depending on the usage conditions.

- Compatible Fluid / Steam
- Inner Tube / Heat Resistant Synthetic Rubber
- Outer Cover / Heat Resistant Synthetic Rubber
- Temperature Range: fluid / 4°C to 210°C(39°F to 410°F)
- Temperature Range : ambient / -40°C to 70°C(-40°F to 158°F)

SA Maximum Working Pressure <b>2.0MPa</b> <b>300PSI</b>	I.D.		O.D.		Max.W.P.		Min.B.P.		Min.B.R.		Weight		Reinforcement	Compatible coupling/relevant page Factory-assembled
	inch	mm	inch	mm	psi	MPa	psi	MPa	inch	mm	lbs/ft	g/m		
	SA08	1/2	12.7	1.03	26.1	300	2.0	1,800	12.0	5.91	150	0.41		
SA12	3/4	19.0	1.28	32.4	8.27					210	0.54	810		
SA16	1	25.4	1.64	41.6	9.84					250	0.88	1,320		

⚠ SA hose does not fit mineral oil application.

\*For information about other size hoses, contact us. \*Be sure to read the following description.

### Be sure to read the following before use

● Use SA series steam hoses to convey hot water condensate<sup>\*1</sup> or saturated steam<sup>\*2</sup>. Do not use them to convey superheated steam<sup>\*3</sup> or a mixture of steam and air. Doing so could deteriorate the inner tube rubber, significantly reducing the life of the hose. (The terms marked with an asterisk are described below.)

**\*1 Hot water condensate**  
The water evaporation temperature, which depends on pressure, is also called the saturation temperature. Water at the saturation temperature is called saturated water. While this saturated water is being heated, it continues to evaporate without any increase in its temperature. The condensate (vapor + water) generated at this stage is called hot water condensate.

**\*2 Saturated steam**  
While the hot water condensate is being heated, the water continues to evaporate and finally disappears. The steam generated when there is no water remaining is called saturated steam.

**\*3 Superheated steam**  
When the saturated steam is further heated, its temperature rises. This steam is called superheated steam.

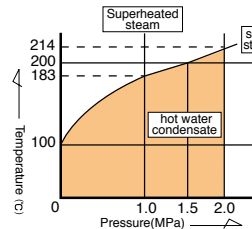

⚠ Use this hose in    area.

In case of 200°C, if pressure is less than 1.5Mpa, hose life is reduced dramatically by superheated steam conditions. Therefore in case of 200°C situation, pressure 1.5 to 2.0 Mpa is required.

## Couplings SK Series

R

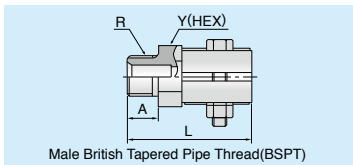

Catalog Number	Thread	Y		A		(L)		Weight	
		inch	mm	inch	mm	inch	mm	lbs	g
SK08R	1/2	1.06	27	0.71	18	1.06	71	0.68	310
SK12R	3/4	1.42	36	0.79	20	1.42	83	1.22	555
SK16R	1	1.61	41	0.87	22	1.61	98	1.36	615

F

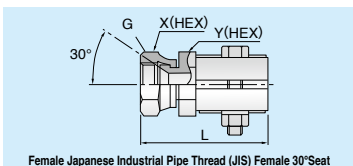

Catalog Number	Thread	Y		(L)		Weight			
		inch	mm	inch	mm	lbs	g		
SK08F	1/2	1.06	27			2.80	71	0.69	315
SK12F	3/4	1.42	36			3.46	88	1.34	610
SK16F	1	1.61	41			3.98	101	1.48	670

Standard product — Material: SS or SC equivalent steel, Surface: Zinc plating or chromate treatment (for cores only)

### How to install SK series couplings

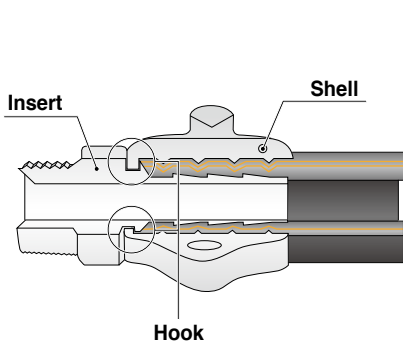

- Set the hook of shell in the groove of insert
- SK series is all re-usable type  
Retighten the bolt if leakage from coupling is found  
If retightening can not stop leakage, cut the hose and retighten.

In case the clamping portion becomes loose after a certain period of usage, retightening will be required.

- ⚠ Not following these instructions will lead to hose failure like hose coupling blow-off and leakage.
- Tighten the bolt referring to the following crevice figure

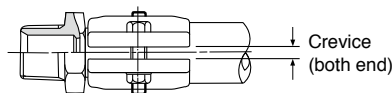

Hose size	Crevice (mm)	Tolerance
SA08	2	±1
SA12	5	
SA16	6	

### Reinforcing

1W

1 wire braid

1B

1 Special synthetic fiber braid



# Heat- and Oil-resistant Hoses

- Compatible Fluids / Mineral hydraulic oil or mineral engine oil
- Inner Tube: Heat- and oil-resistant synthetic rubber
- Outer Cover: Heat-, oil-, and weather-resistant synthetic rubber
- Temperature Range: fluid / -40°C to 135°C (-40°F to 275°F)
- Temperature Range: ambient / -40°C to 100°C (-40°F to 212°F)

HM	Maximum Working Pressure	Catalog Number	I.D.		O.D.		Max.W.P.		Min.B.P.		Min.B.R.		Weight		Reinforcement	Compatible coupling/relevant page
			inch	mm	inch	mm	psi	MPa	psi	MPa	inch	mm	lbs/ft	g/m		
			Factory-assembled													
	<b>7.0MPa</b>	HM12	3/4	19.0	1.04	26.5	1,000	7.0	4,000	28.0	5.51	140	0.37	550	1W	UN/27
	<b>1,000PSI</b>	HM16	1	25.4	1.31	33.3					7.09	180	0.57	850		

## Push on Hose

You can easily attach couplings to these hoses without using a crimping machine. This enables on-site assembly, so you no longer need to have extra assembled hoses in stock.

ACT	Maximum Working Pressure	Catalog Number	I.D.		O.D.		Max.W.P.		Min.B.P.		Min.B.R.		Weight		Reinforcement	Compatible coupling/relevant page
			inch	mm	inch	mm	psi	MPa	psi	MPa	inch	mm	lbs/ft	g/m		
			Factory-assembled													
	<b>2.0MPa</b>	ACT04	1/4	6.3	0.49	12.5	300	2.0	1,500	10.0	2.36	60	0.08	120	1B	AT
	<b>300PSI</b>	ACT06	3/8	9.5	0.63	16.0					2.76	70	0.11	170		
		ACT08	1/2	12.7	0.75	19.0					4.72	120	0.15	220		

- Compatible Fluid / Mineral Oil, Water
- Inner Tube / Oil Resistant Synthetic Rubber
- Outer Cover / Weather Resistant Synthetic Rubber
- Temperature Range: fluid / -40°C to 93°C(Oil), 0°C to 50°C(Water) -40°F to 199°F(Oil), 32°F to 122°F(Water)
- Temperature Range: ambient / -40°C to 70°C(Oil), 0°C to 70°C(Water) -40°F to 158°F(Oil), 32°F to 158°F(Water)
- \*Check the delivery dates of 100m hoses, as they are available on request.

## Couplings and adaptor AT series and Adapters

### ■ Couplings materials : Brass

R	Catalog Number	R	Y		A		D		(L)		W	
			inch	mm	inch	mm	inch	mm	inch	mm		lbs
	AT04R	1/4	0.67	17	0.51	13	0.31	8	1.69	43	0.07	30
	AT06R	3/8	0.75	19	0.59	15	0.47	12	1.77	45	0.10	45
	AT08R	1/2	0.94	24	0.71	18	0.59	15	2.05	52	0.18	80
	AT12R	3/4	1.18	30	0.79	20	0.83	21	2.83	72	0.39	175

F	Catalog Number	R	Y		D		(L)		W	
			inch	mm	inch	mm	inch	mm		lbs
	AT04F	1/4	0.67	17	0.31	8	1.57	40	0.07	30
	AT06F	3/8	0.75	19	0.47	12	1.69	43	0.09	40
	AT08F	1/2	0.94	24	0.59	15	1.97	50	0.15	70
	AT12F	3/4	1.26	32	0.83	21	2.68	68	0.26	120

⚠ tightening torque ( page 82 )

### ■ Adapters materials : Brass

Catalog Number	R	Y		(L)		A		B		W	
		inch	mm	inch	mm	inch	mm	inch	mm		lbs
8001RG04H14B	1/4	0.55	14	1.45	37	0.51	13	0.63	16	0.07	30
8001RG06H19B	3/8	0.75	19	1.61	41	0.59	15	0.71	18	0.11	50
8001RG08H22B	1/2	0.87	22	1.89	48	0.71	18	0.79	20	0.20	90
8001RG12H30B	3/4	1.18	30	2.13	54	0.79	20	0.87	22	0.35	160

Catalog Number	R	C		D		G		W	
		inch	mm	inch	mm	inch	mm		lbs
8025RG04	1/4	1.06	27	0.94	24	0.43	11	0.11	50
8025RG06	3/8	1.18	30	1.06	27	0.43	11	0.15	70
8025RG08	1/2	1.26	32	1.18	30	0.55	14	0.24	110
8025RG12	3/4	1.46	37	1.57	40	0.87	22	0.46	210

### ■ How to install coupling

Cut the hose perpendicular to the axis by tube cutter. Put water or soap suds hose inside and inserting portion of coupling.

⚠ Cutting surface should be less than 10 degree.

Fix the coupling with clamp and insert the hose.

⚠ Short grip will cause oil leakage.

# Special Application Rubber Hoses

## WH Series For Pressure Washer

- Compatible Fluid / Water
- Inner Tube / Hot Water Resistant Synthetic Rubber
- Outer Cover / Weather Resistant Synthetic Rubber
- Temperature Range: fluid / 0°C to 120°C(32°F to 248°F)
- Temperature Range: ambient / 0°C to 70°C(32°F to 158°F)

### WH21

Maximum Working Pressure

**20.5MPa**  
**3,000PSI**

Catalog Number	I.D.		O.D.		Max.W.P.		Min.B.P.		Min.B.R.		Weight		Reinforcement	Compatible coupling/relevant page	
	inch	mm	inch	mm	psi	MPa	psi	MPa	inch	mm	lbs/ft	g/m		Factory-assembled	UNCRIMP-crimped
WH2106	3/8	9.5	0.68	17.2	3,000	20.5	9,000	61.5	3.35	85	0.24	360	1W	UF/45	GA(UL)/45

⚠ WH hose does not fit mineral oil application.

## Rubber Hoses for Both Water-Glycol and Mineral Hydraulic Oil

- Compatible Fluid / Water-glycol and mineral hydraulic oil
- Inner Tube / Oil- and water-glycol-resistant synthetic rubber
- Outer Cover / Weather-resistant synthetic rubber
- Temperature Range: fluid / -40°C to 60°C (-40°F to 140°F) for water-glycol, -40°C to 100°C (-40°F to 212°F) for oil
- Temperature Range: ambient / -40°C to 60°C (-40°F to 140°F) for water-glycol, -40°C to 70°C (-40°F to 158°F) for oil

### WE21

Maximum Working Pressure

**20.5MPa**  
**3,000PSI**

Catalog Number	I.D.		O.D.		Max.W.P.		Min.B.P.		Min.B.R.		Weight		Reinforcement	Compatible coupling/relevant page	
	inch	mm	inch	mm	psi	MPa	psi	MPa	inch	mm	lbs/ft	g/m		Factory-assembled	UNCRIMP-crimped
WE2104	1/4	6.3	0.59	15.1	3,000	20.5	8,000	82.0	3.15	80	0.82	370	2W	UZ/34	UZ/34
WE2106	3/8	9.5	0.75	19.1					3.94	100	1.10	500		UB/34	UB/34
WE2108	1/2	12.7	0.87	22.2					5.51	140	1.43	650		UZ/34	
WE2112-22	3/4	19.0	1.19	30.0					8.27	210	3.53	1,600	4S	UB/34	
WE2116-22	1	25.4	1.46	37.2					10.63	270	4.41	2,000			
WE2120-22	1-1/4	31.8	1.88	47.7					12.60	320	8.38	3,800			
WE2124-22	1-1/2	38.1	2.20	56.0					15.75	400	9.92	4,500			
WE2132	2	50.8	2.76	70.0					22.05	560	12.79	5,800	6S	KN/41	-

⚠ Warning We recommend using couplings on which the wetted parts only are nickel chrome plated (the catalog numbers of these couplings end with X103). Do not use high water base fluid (HWBF) with the hoses listed above. Doing so could cause the hoses to burst or fluid to leak. Severe personal injury or death may result if these instructions are not followed.

### WE28

Maximum Working Pressure

**27.5MPa**  
**4,000PSI**

Catalog Number	I.D.		O.D.		Max.W.P.		Min.B.P.		Min.B.R.		Weight		Reinforcement	Compatible coupling/relevant page	
	inch	mm	inch	mm	psi	MPa	psi	MPa	inch	mm	lbs/ft	g/m		Factory-assembled	UNCRIMP-crimped
WE2804	1/4	6.3	0.59	15.1	4,000	27.5	16,000	112.0	2.76	70	0.84	380	2W	UZ/34	UZ/34
WE2806	3/8	9.5	0.75	19.1					3.54	90	1.17	530		UB/34	UB/34
WE2808	1/2	12.7	0.88	22.4					3.94	100	1.48	670		UZ/34	
WE2812-22	3/4	19.0	1.19	30.1					6.69	170	3.57	1,350	4S	UB/34	
WE2816	1	25.4	1.56	39.5					8.66	220	5.07	2,300			GB/45
WE2820	1-1/4	31.8	1.88	47.7					11.81	300	7.94	3,600			UB/34
WE2824	1-1/2	38.1	2.20	56.0					14.17	360	9.48	4,300			
WE2832	2	50.8	2.91	74.0					16.93	430	17.42	7,900	6S	KD/41	-

⚠ Warning We recommend using couplings on which the wetted parts only are nickel chrome plated (the catalog numbers of these couplings end with X103). Do not use high water base fluid (HWBF) with the hoses listed above. Doing so could cause the hoses to burst or fluid to leak. Severe personal injury or death may result if these instructions are not followed.

### Reinforcing

**1W**

1 wire braid

**2W**

2 wire braids

**4C**

4 fabric spiral

# PA03-DA Series For Air

- Compatible Fluid / Air  
\*It is usable for not only air with misted oil but also dry air
- Inner Tube / Weather Resistant Synthetic Rubber
- Outer Cover / Weather Resistant Synthetic Rubber
- Temperature Range: fluid / -40°C to 60°C (-40°F to 140°F)
- Temperature Range: ambient / -40°C to 60°C (-40°F to 140°F)

## PA03-DA

Maximum Working Pressure

**3.5MPa  
500PSI**

Catalog Number	I.D.		O.D.		Max.W.P.		Min.B.P.		Min.B.R.		Weight		Reinforcement	Compatible coupling/relevant page	
	inch	mm	inch	mm	psi	MPa	psi	MPa	inch	mm	lbs/ft	g/m		Factory-assembled	UNCRIMP-cripped
PA0304-DA	1/4	6.3	0.55	14.0	500	3.5	2,000	14.0	2.17	55	0.12	180	4C	AS/27	UL/30
PA0306-DA	3/8	9.5	0.69	17.4					2.56	65	0.16	240			
PA0308-DA	1/2	12.7	0.83	21.2					3.54	90	0.20	300			
PA0312-DA	3/4	19.0	1.24	31.4					5.12	135	0.43	650			
PA0316-DA	1	25.4	1.48	37.5					6.69	170	0.55	840		UT/27	

4S

4 spiral wires



6S

6 spiral wires



# Special Purpose Hose

## JUMBO ACE

- Compatible Fluid  
Mineral Hydraulic Oil
- Inner Tube  
Oil-resistant synthetic rubber
- Outer Cover  
Weather-resistant synthetic rubber
- Temperature Range : fluid  
-40°C to 100°C (-40°F to 212°F)
- Recommended Temperature Range: ambient  
-40°C to 70°C (-40°F to 158°F)

### 1 Large-bore high-pressure hoses with extended life and increased fatigue endurance

The result of our extensive materials research, the JUMBO ACE series of hoses provide high flexibility while offering outstanding durability. They have survived shock pressure tests in which they have a maximum working pressure equal to 1/4 of the minimum burst pressure and were subjected to 200,000 applications.

### 2 Maximum length of 40m enables an extended range of applications

Conventional large-bore high-pressure hoses typically have a length of up to 20m. The JUMBO ACE series features a maximum length of 40m, marking a breakthrough in technology. The JUMBO ACE series is a revolutionary line of hoses that meets the needs of large oil pressure systems.

### 3 Compact and lightweight design offers significantly increased work efficiency

The JUMBO ACE series produces the expected effect as a large-bore high-pressure hose. For example, if the fluid speed is 4m/sec at a maximum working pressure of 20.5MPa and a flow rate of 900 liters/min, then three EQ2124 (38φ) hoses by Bridgestone are required. These hoses can be replaced by just one JUMBO ACE JBS40 hose. The JUMBO ACE series enables compact plumbing designs and weighs about two thirds of the weight of conventional hoses.

## JBT/JBF/JBS

Maximum Working Pressure

3.0~20.5MPa

400~3,000PSI

Catalog Number	I.D.		O.D.		Max.W.P.		Min.B.P.		Min.B.R.		Weight		Reinforcement	Compatible coupling/relevant page Factory-assembled
	inch	mm	inch	mm	psi	MPa	psi	MPa	inch	mm	lbs/ft	g/m		
JBT40	2 1/2	63.5	3.11	79.0	700	4.9	2,800	19.5	23.23	590	2.40	3,600	2W	EC
JBT48	3	76.2	3.58	91.0	400	3.0	1,600	12.0	31.50	760	2.47	3,700		
JBF40	2 1/2	63.5	3.24	82.4	2,000	14.0	8,000	56.0	25.98	660	3.67	5,500	4S	DX
JBF48	3	76.2	3.77	95.8	1,500	10.5	6,000	42.0	29.53	750	4.33	6,500		
JBS40	2 1/2	63.5	3.35	86.4	3,000	20.5	12,000	82.0	25.98	660	5.13	7,700	6S	EX
JBS48	3	76.2	3.91	99.1	2,500	17.0	10,000	68.0	29.53	750	6.07	9,100		

## Couplings EC / DX / EX Series

R6

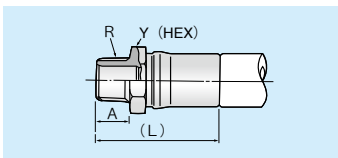

Catalog Number	Thread	Y		A		(L)		Weight	
		inch	mm	inch	mm	inch	mm	lbs	kg
EC40R6	2 1/2	3.54	90	1.26	32	5.79	147	5.95	2.7
EC48R6	3	3.94	100	1.30	33	5.79	147	6.61	3.0

F

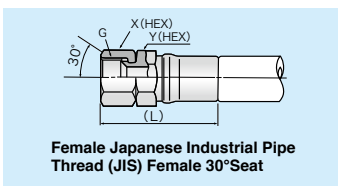

Catalog Number	Thread	Y		A		(L)		Weight	
		inch	mm	inch	mm	inch	mm	lbs	kg
EC40F	2 1/2	3.54	90	3.54	90	5.59	142	6.39	2.9
EC48F	3	3.94	100	3.94	100	4.69	119	9.70	4.4

K

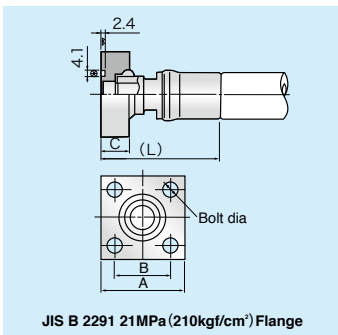

Catalog Number	A φ		B		C		(L)		Bolt	Bolt dia		Weight	
	inch	mm	inch	mm	inch	mm	inch	mm		inch	mm	lbs	kg
DX40K65	5.51	140	3.94	100	1.77	45	6.34	161	M20	0.87	22	16.76	7.6
EX40K65	5.51	140	3.94	100	1.77	45	7.64	194	M20	0.87	22	20.73	9.4
DX48K80	6.10	155	4.41	112	1.77	45	7.60	193	M22	0.94	24	22.71	10.3
EX48K80	6.10	155	4.41	112	1.77	45	8.98	228	M22	0.94	24	25.80	11.7
DX40K265	5.04	128	3.62	92	1.77	45	6.34	161	M20	0.87	22	14.33	6.5
EX40K265	5.04	128	3.62	92	1.77	45	7.72	196	M20	0.87	22	18.30	8.3
DX48K280	5.51	140	4.06	103	1.77	45	7.64	194	M22	0.94	24	19.40	8.8
EX48K280	5.51	140	4.06	103	1.77	45	8.98	228	M22	0.94	24	22.93	10.4

Materials : Steel with Zinc Plating

## Reinforcing

2W

2 wire braids

4S

4 spiral wires

6S

6 spiral wires

# Couplings AS / LS / UT / UN / LC series

R

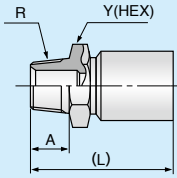

Male British Tapered Pipe Thread (BSPT)

Catalog Number	Thread	Y		A		(L)		Weight	
		inch	mm	inch	mm	inch	mm	lbs	g
AS04R	1/4	0.67	17	0.51	13	1.61	41	0.07	30
LS04R	1/4	0.67	17	0.51	13	1.61	41	0.06	30
AS06R	3/8	0.75	19	0.59	15	1.81	46	0.12	55
LS06R	3/8	0.75	19	0.59	15	1.81	46	0.11	50
AS08R	1/2	0.87	22	0.71	18	2.76	70	0.25	115
LS08R	1/2	0.87	22	0.71	18	2.01	51	0.17	80
UT1012R	3/4	1.18	30	0.79	20	2.87	73	0.41	185
UT12R	3/4	1.18	30	0.79	20	2.87	73	0.47	215
UN12R	3/4	1.18	30	0.79	20	3.35	85	0.57	257
UT16R	1	1.42	36	0.87	22	3.23	82	0.72	325
UN16R	1	1.42	36	0.87	22	3.50	89	0.88	401
UT20R	1 1/4	1.81	46	0.98	25	4.45	113	1.42	645
LC20R	1 1/4	1.81	46	0.98	25	4.45	113	0.42	645
LC24R	1 1/2	1.97	50	0.98	25	4.53	115	1.66	755
LC32R	2	2.56	65	1.14	29	5.59	142	2.82	1,280

F

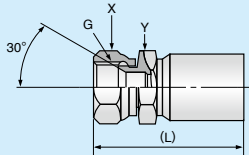

Female Japanese Industrial Pipe Thread (JIS) Female 30° Seat

Catalog Number	Thread	X		Y		(L)		Weight	
		inch	mm	inch	mm	inch	mm	lbs	g
AS04F	1/4	0.75	19	0.67	17	1.85	47	0.11	50
LS04F	1/4	0.75	19	0.67	17	1.85	47	0.10	45
AS06F	3/8	0.87	22	0.75	19	1.97	50	0.15	70
LS06F	3/8	0.87	22	0.75	19	1.97	50	0.14	65
AS08F	1/2	1.06	27	0.87	22	2.87	73	0.31	140
LS08F	1/2	1.06	27	0.87	22	2.13	54	0.23	105
UT1012F	3/4	1.42	36	1.18	30	3.07	78	0.56	255
UT12F	3/4	1.42	36	1.18	30	3.11	79	0.64	290
UN12F	3/4	1.42	36	1.18	30	3.58	91	0.73	332
UT16F	1	1.61	41	1.42	36	3.47	88	0.90	410
UN16F	1	1.61	41	1.42	36	3.74	95	1.07	486
UT20F	1 1/4	1.97	50	1.81	46	4.72	120	1.64	745
LC20F	1 1/4	1.97	50	1.81	46	4.72	120	1.64	745
LC24F	1 1/2	2.17	55	1.97	50	4.88	124	1.90	865
LC32F	2	2.76	70	2.56	65	5.91	150	3.34	1,515

C

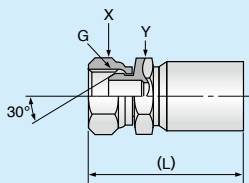

Female British Parallel Pipe Thread Male 30° Seat (BSPOR)

Catalog Number	Thread	X		Y		(L)		Weight	
		inch	mm	inch	mm	inch	mm	lbs	g
AS04C	1/4	0.75	19	0.67	17	1.85	47	0.11	50
LS04C	1/4	0.75	19	0.67	17	1.85	47	0.11	50
AS06C	3/8	0.87	22	0.75	19	1.97	50	0.15	70
LS06C	3/8	0.87	22	0.75	19	1.97	50	0.15	70
AS08C	1/2	1.06	27	0.87	22	2.87	73	0.31	140
LS08C	1/2	1.06	27	0.87	22	2.13	54	0.23	105
UT1012C	3/4	1.42	36	1.18	30	3.11	79	0.42	270
UT12C	3/4	1.42	36	1.18	30	3.11	79	0.66	300
UN12C	3/4	1.42	36	1.18	30	3.58	91	0.74	337
UT16C	1	1.61	41	1.42	36	3.47	88	0.91	415
UN16C	1	1.61	41	1.42	36	3.74	95	1.08	491
UT20C	1 1/4	1.97	50	1.81	46	4.72	120	1.68	760
LC20C	1 1/4	1.97	50	1.81	46	4.72	120	1.67	760
LC24C	1 1/2	2.17	55	1.97	50	4.88	124	1.97	895
LC32C	2	2.76	70	2.56	65	5.91	150	3.39	1,540

CR4

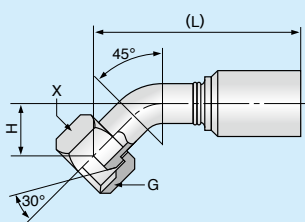

Female Parallel Pipe Thread, Bent 45° (Male 30° Seat)

Catalog Number	Thread	X		H		(L)		Weight	
		inch	mm	inch	mm	inch	mm	lbs	g
AS04CR4	1/4	0.75	19	0.94	24	2.36	60	0.12	55
AS06CR4	3/8	0.87	22	1.02	26	2.80	71	0.19	85
LS06CR4	3/8	0.87	22	1.02	26	2.80	71	0.18	80
AS08CR4	1/2	1.06	27	0.87	22	4.17	106	0.44	200
UT12CR4	3/4	1.42	36	1.14	29	3.94	100	0.77	350
UN12CR4	3/4	1.42	36	1.14	29	4.41	112	0.85	387
UT16CR4	1	1.61	41	1.30	33	4.72	120	1.18	535
UN16CR4	1	1.61	41	1.30	33	5.00	127	1.35	611
UT20CR4	1 1/4	1.97	50	1.50	38	5.94	151	2.17	985
LC24CR4	1 1/2	2.17	55	2.05	52	8.58	218	3.87	1,755

Standard product — Material: SS or SC equivalent steel, Surface: Zinc plating or chromate treatment

# Couplings AS / LS / UT / UN / LC series

**CR9**

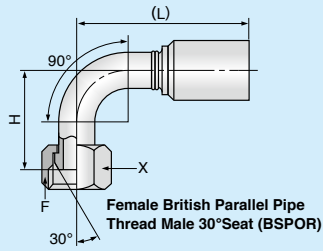

Catalog Number	W Thread	X		H		(L)		Weight	
		inch	mm	inch	mm	inch	mm	lbs	g
AS04CR9	1/4	0.75	19	0.94	24	2.01	51	0.12	55
LS04CR9	1/4	0.75	19	0.94	24	2.01	51	0.11	50
AS06CR9	3/8	0.87	22	1.50	38	2.01	51	0.19	85
LS06CR9	3/8	0.87	22	1.50	38	2.01	51	0.18	80
AS08CR9	1/2	1.06	27	1.81	46	3.62	92	0.44	200
LS08CR9	1/2	1.06	27	1.81	46	2.72	69	0.33	150
UT12CR9	3/4	1.42	36	2.36	60	3.54	90	0.84	380
UN12CR9	3/4	1.42	36	2.36	60	4.02	102	0.92	417
UT16CR9	1	1.61	41	2.76	70	4.29	109	1.33	605
UN16CR9	1	1.61	41	2.76	70	4.57	116	1.49	676
UT20CR9	1 1/4	1.97	50	3.15	80	5.47	139	2.44	1,105
LC2420001	1 1/2	2.17	55	4.13	105	7.01	178	2.82	1,280

**S**

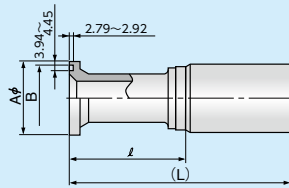

Flange Head S CODE 61 Flange

Catalog Number	Aφ		B		φ		(L)		Weight	
	inch	mm	inch	mm	inch	mm	inch	mm	lbs	g
UT12S	1.50	38.10	1.255~1.250	31.88~31.75	1.38	35	2.95	75	0.53	240
UT16S	1.75	44.45	1.565~1.560	39.75~39.62	1.38	35	3.43	87	0.74	335
UT20S	2.00	50.80	1.755~1.750	44.58~44.45	1.73	44	4.53	115	1.30	590
LC24S	2.37	60.32	2.125~2.115	53.98~53.72	1.73	44	4.53	115	1.43	650

**SR4**

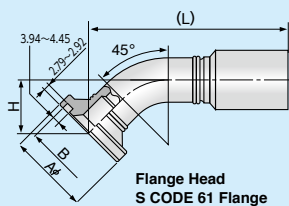

Flange Head S CODE 61 Flange

Catalog Number	Aφ		B		H		(L)		Weight	
	inch	mm	inch	mm	inch	mm	inch	mm	lbs	g
UT12SR4	1.50	38.10	1.255~1.250	31.88~31.75	0.98	25	3.78	96	0.63	285
UT16SR4	1.75	44.45	1.565~1.560	39.75~39.62	1.10	28	4.17	106	0.93	420
UT20SR4	2.00	50.80	1.755~1.750	44.58~44.45	1.18	30	5.28	134	1.48	670
LC24SR4	2.37	60.32	2.125~2.115	53.98~53.72	1.46	37	6.02	153	2.15	975

**SR9**

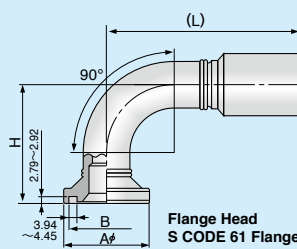

Flange Head S CODE 61 Flange

Catalog Number	Aφ		B		H		(L)		Weight	
	inch	mm	inch	mm	inch	mm	inch	mm	lbs	g
UT12SR9	1.50	38.10	1.255~1.250	31.88~31.75	2.13	54	3.50	89	0.72	325
UT1620SR9	2.00	50.80	1.755~1.750	44.58~44.45	2.64	67	4.06	103	1.15	520
UT16SR9	1.75	44.45	1.565~1.560	39.75~39.62	2.36	60	4.02	102	1.05	475
UT20SR9	2.00	50.80	1.755~1.750	44.58~44.45	2.64	67	5.39	137	1.80	815
LC24SR9	2.37	60.32	2.125~2.115	53.98~53.72	3.15	80	5.63	143	1.97	895

**G**

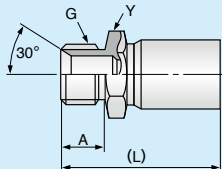

Male British Parallel Pipe Thread(BSP)

Catalog Number	W Thread	Y		A		(L)		Weight	
		inch	mm	inch	mm	inch	mm	lbs	g
AS04G	1/4	0.67	17	0.51	13	1.61	41	1.18	30
LS04G	1/4	0.67	17	0.51	13	1.61	41	1.18	30
AS06G	3/8	0.75	19	0.59	15	1.81	46	1.97	50
LS06G	3/8	0.75	19	0.59	15	1.81	46	1.97	50
AS08G	1/2	0.87	22	0.71	18	2.76	70	4.33	110
LS08G	1/2	0.87	22	0.71	18	2.01	51	3.54	90
UT12G	3/4	1.18	30	0.79	20	2.87	73	8.46	215
UT16G	1	1.42	36	0.87	22	3.23	82	12.80	325
UT20G	1 1/4	1.81	46	0.98	25	4.45	113	25.00	635
LC24G	1 1/2	1.97	50	0.98	25	4.53	115	29.33	745
LC32G	2	2.56	65	1.14	29	5.59	142	50.20	1,275

Standard product — Material: SS or SC equivalent steel, Surface: Zinc plating or chromate treatment

**F4**

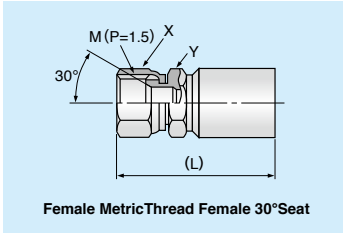

Catalog Number	Thread	X		Y		(L)		Weight	
		inch	mm	inch	mm	inch	mm	lbs	g
UT12F4	M30×1.5	1.42	36	1.18	30	3.27	83	0.64	290
UT16F4	M33×1.5	1.61	41	1.42	36	3.78	96	0.97	440

**F2**

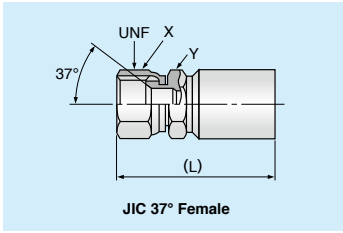

Catalog Number	Thread	X		Y		(L)		Weight	
		inch	mm	inch	mm	inch	mm	lbs	g
UT12F2	1 1/16-12	1.42	36	1.18	30	3.07	78	0.65	295
UT16F2	1 5/16-12	1.61	41	1.42	36	3.43	87	0.89	405

**F2R9**

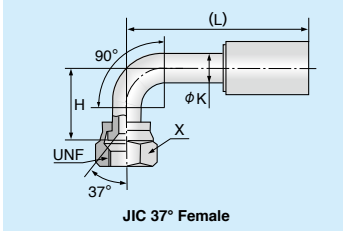

Catalog Number	Thread	X		H		(L)		Weight	
		inch	mm	inch	mm	inch	mm	lbs	g
UT12F2R9	1 1/16-12	1.25	31.8	2.09	53	3.78	96	0.68	310
UT16F2R9	1 5/16-12	1.50	38	2.48	63	4.56	103	1.05	475

**Q2**

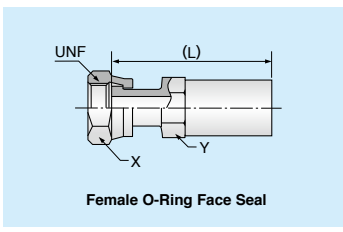

Catalog Number	Thread	X		Y		(L)		Weight	
		inch	mm	inch	mm	inch	mm	lbs	g
AS08Q2	13/16-16	1.06	27	0.87	22	2.87	73	0.34	155
UT10Q2H27	1-14	1.26	32	1.06	27	2.95	75	0.51	230
UT12Q2	1 3/16-12	1.42	36	1.18	30	3.07	78	0.68	310
UN12Q2	1 3/4-12	1.42	36	1.18	30	3.54	90	0.76	347
UT16Q2	1 7/16-12	1.61	41	1.42	36	3.54	90	1.00	455
UN16Q2	1 7/8-12	1.61	41	1.42	36	3.82	97	1.17	531

**Q2R4**

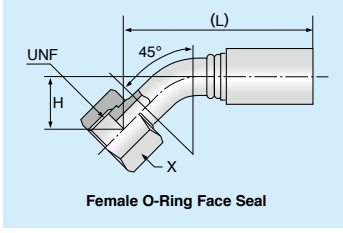

Catalog Number	Thread	X		H		(L)		Weight	
		inch	mm	inch	mm	inch	mm	lbs	g
UT12Q2R4	1 3/16-12	1.42	36	1.04	26.5	3.78	96	0.72	325
UN12Q2R4	1 3/4-12	1.42	36	1.02	26	4.17	106	0.80	362
UT16Q2R4	1 7/16-12	1.61	41	1.18	30	4.57	116	1.11	505
UN16Q2R4	1 7/8-12	1.61	41	1.18	30	4.88	124	1.27	576

**Q2R9**

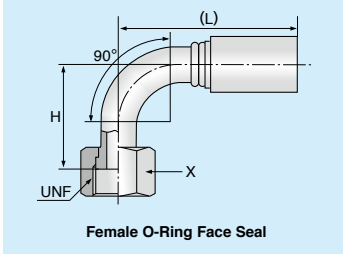

Catalog Number	Thread	X		H		(L)		Weight	
		inch	mm	inch	mm	inch	mm	lbs	g
UT12Q2R9	1 3/16-12	1.42	36	2.31	58.7	3.46	88	0.79	360
UN12Q2R9	1 3/4-12	1.42	36	2.28	58	3.90	99	0.88	397
UT16Q2R9	1 7/16-12	1.61	41	2.64	67	4.29	109	1.25	565
UN16Q2R9	1 7/8-12	1.61	41	2.64	67	4.57	116	1.41	641

Standard product — Material: SS or SC equivalent steel, Surface: Zinc plating or chromate treatment

**R**

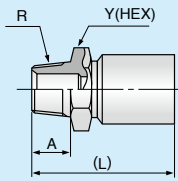

Male British Tapered Pipe Thread(BSPT)

Catalog Number	Thread	Y		A		(L)		Weight	
		inch	mm	inch	mm	inch	mm	lbs	g
UL04R	1/4	0.67	17	0.51	13	1.97	50	0.10	45
UL06R	3/8	0.75	19	0.59	15	2.28	58	0.19	85
UL08R	1/2	0.87	22	0.71	18	2.52	64	0.25	115
UL1012R	3/4	1.18	30	0.79	20	2.91	74	0.43	195
UL12R	3/4	1.18	30	0.79	20	3.03	77	0.53	240
UX12R	3/4	1.18	30	0.79	20	3.03	77	0.54	245
UL16R	1	1.42	36	0.87	22	3.43	87	0.79	360
UX16R	1	1.42	36	0.87	22	3.43	87	0.83	375

**F**

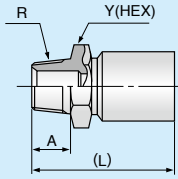

Male British Tapered Pipe Thread(BSPT)

Catalog Number	Thread	X		Y		(L)		Weight	
		inch	mm	inch	mm	inch	mm	lbs	g
UL04F	1/4	0.59	19	0.67	17	2.20	56	0.14	65
UL06F	3/8	0.87	22	0.75	19	2.44	62	0.22	100
UL08F	1/2	1.06	27	0.87	22	2.64	67	0.31	140
UL1012F	3/4	1.42	36	1.18	30	3.11	79	0.58	265
UL12F	3/4	1.42	36	1.18	30	3.27	83	0.69	315
UX12F	3/4	1.42	36	1.18	30	3.27	83	0.71	320
UL16F	1	1.61	41	1.42	36	3.66	93	0.98	445
UX16F	1	1.61	41	1.42	36	3.66	93	1.01	460

**C**

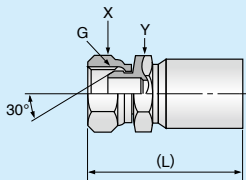

Female British Parallel Pipe Thread Male 30°Seat(BSPOR)

Catalog Number	Thread	X		Y		(L)		Weight	
		inch	mm	inch	mm	inch	mm	lbs	g
UL04C	1/4	0.75	19	0.67	17	2.20	56	0.14	65
UL06C	3/8	0.87	22	0.75	19	2.44	62	0.22	100
UL08C	1/2	1.06	27	0.87	22	2.64	67	0.31	140
UL1012C	3/4	1.42	36	1.18	30	3.07	78	0.57	260
UL1008CH27	1/2	1.06	27	1.06	27	2.87	73	0.72	190
UL12C	3/4	1.42	36	1.18	30	3.27	83	0.70	320
UX12C	3/4	1.42	36	1.18	30	3.27	83	0.72	325
UL16C	1	1.61	41	1.42	36	3.66	93	0.99	450
UX16C	1	1.61	41	1.42	36	3.66	93	1.04	470

**CR4**

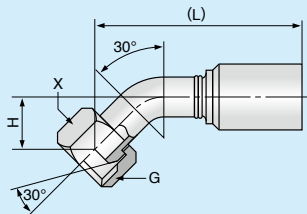

Female British Parallel Pipe Thread Male 30°Seat(BSPOR)

Catalog Number	Thread	X		H		(L)		Weight	
		inch	mm	inch	mm	inch	mm	lbs	g
UL04CR4	1/4	0.75	19	0.94	24	3.03	77	0.17	75
UL06CR4	3/8	0.87	22	1.02	26	3.43	87	0.28	125
UL08CR4	1/2	1.06	27	0.87	22	4.41	112	0.44	200
UL1012CR4	3/4	1.42	36	1.14	29	3.98	101	0.71	320
UL12CR4	3/4	1.42	36	1.14	29	4.09	104	0.82	370
UX12CR4	3/4	1.42	36	1.14	29	4.09	104	0.83	375
UL16CR4	1	1.61	41	1.30	33	4.92	125	1.26	570
UX16CR4	1	1.61	41	1.30	33	4.92	125	1.30	590

**CR9**

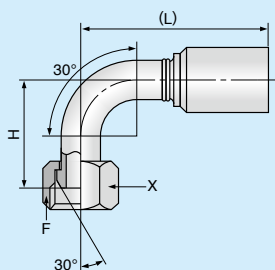

Female British Parallel Pipe Thread Male 30°Seat(BSPOR)

Catalog Number	Thread	X		H		(L)		Weight	
		inch	mm	inch	mm	inch	mm	lbs	g
UL04CR9	1/4	0.75	19	0.94	24	2.36	60	0.15	70
UL06CR9	3/8	0.87	22	1.50	38	2.64	67	0.28	125
UL08CR9	1/2	1.06	27	1.81	46	3.39	86	0.44	200
UL1012CR9	3/4	1.42	36	2.36	60	3.58	91	0.78	355
UL12CR9	3/4	1.42	36	2.36	60	3.70	94	0.88	400
UX12CR9	3/4	1.42	36	2.36	60	3.70	94	0.89	405
UL16CR9	1	1.61	41	2.76	70	4.49	114	1.41	640
UX16CR9	1	1.61	41	2.76	70	4.49	114	1.44	655

Standard product — Material: SS or SC equivalent steel, Surface: Zinc plating or chromate treatment



**S**

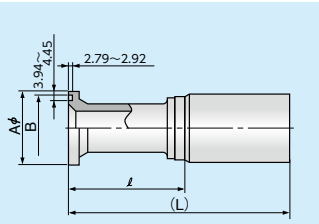

Flange Head S CODE 61 Flange

Catalog Number	Aφ		B		φ		(L)		Weight	
	inch	mm	inch	mm	inch	mm	inch	mm	lbs	g
UL08S	1.19	30.20	1.005~1.000	25.53~25.40	1.38	35	2.83	72	0.29	130
UL1012SCV	1.50	38.10	1.255~1.250	31.88~31.75	1.46	37	3.31	84	0.51	230
UL12S	1.50	38.10	1.255~1.250	31.88~31.75	1.38	35	3.23	82	0.57	260
UX12S	1.50	38.10	1.255~1.250	31.88~31.75	1.38	35	3.23	82	0.58	265
UL16S	1.75	44.45	1.565~1.560	39.75~39.62	1.38	35	3.43	87	0.82	370
UX16S	1.75	44.45	1.565~1.560	39.75~39.62	1.38	35	3.43	87	0.85	385

**SR4**

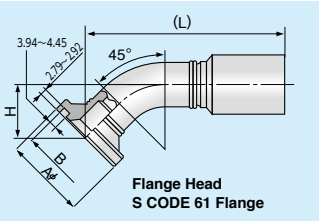

Flange Head S CODE 61 Flange

Catalog Number	Aφ		X		H		(L)		Weight	
	inch	mm	inch	mm	inch	mm	inch	mm	lbs	g
UL08SR4	1.19	30.20	1.005~1.000	25.53~25.40	0.79	20	3.03	77	0.31	140
UL1012SR4	1.50	38.10	1.255~1.250	31.88~31.75	0.98	25	4.45	113	0.63	285
UL12SR4	1.50	38.10	1.255~1.250	31.88~31.75	0.98	25	3.94	100	0.68	310
UX12SR4	1.50	38.10	1.255~1.250	31.88~31.75	0.98	25	3.94	100	0.69	315
UL16SR4	1.75	44.45	1.565~1.560	39.75~39.62	1.10	28	4.41	112	1.00	455
UX16SR4	1.75	44.45	1.565~1.560	39.75~39.62	1.10	28	4.37	111	1.05	475

**SR9**

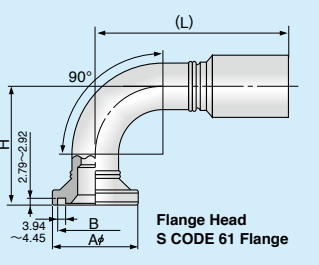

Flange Head S CODE 61 Flange

Catalog Number	Aφ		X		H		(L)		Weight	
	inch	mm	inch	mm	inch	mm	inch	mm	lbs	g
UL08SR9	1.19	30.20	1.005~1.000	25.53~25.40	1.61	41	2.83	72	0.34	155
UL1012SR9	1.50	38.10	1.255~1.250	31.88~31.75	2.13	54	4.25	108	0.58	265
UL12SR9	1.50	38.10	1.255~1.250	31.88~31.75	2.13	54	3.66	93	0.76	345
UX12SR9	1.50	38.10	1.255~1.250	31.88~31.75	2.13	54	3.66	93	0.77	350
UL16SR9	1.75	44.45	1.565~1.560	39.75~39.62	2.36	60	4.25	108	1.12	510
UL1620SR9	2.00	50.80	1.755~1.750	44.58~44.45	2.64	67	4.25	108	1.22	555
UX16SR9	1.75	44.45	1.565~1.560	39.75~39.62	2.36	60	4.21	107	1.16	525

**G**

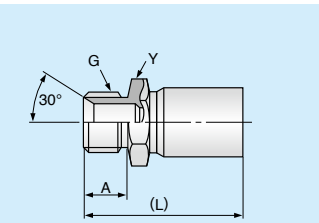

Male British Parallel Pipe Thread(BSPP)

Catalog Number	Thread	Y		A		(L)		Weight	
		inch	mm	inch	mm	inch	mm	lbs	g
UL04G	1/4	0.67	17	0.51	13	1.97	50	0.10	45
UL06G	3/8	0.75	19	0.59	15	2.28	58	0.19	85
UL08G	1/2	0.87	22	0.71	18	2.52	64	0.25	115
UL1012G	3/4	1.18	30	0.79	20	2.91	74	0.42	190
UL12G	3/4	1.18	30	0.79	20	3.03	77	0.52	235
UX12G	3/4	1.18	30	0.79	20	3.03	77	0.53	240
UL16G	1	1.42	36	0.87	22	3.43	87	0.79	360
UX16G	1	1.42	36	0.87	22	3.43	87	0.83	375

**F4**

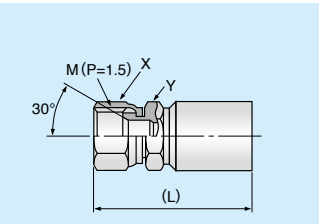

Female Metric Thread Female 30° Seat

Catalog Number	Thread	X		Y		(L)		Weight	
		inch	mm	inch	mm	inch	mm	lbs	g
UL04F4	M14×1.5	0.75	19	0.67	17	2.24	57	0.14	65
UL06F4U24	M18×1.5	0.94	24	0.75	19	2.52	64	0.24	110
UL06F4	M18×1.5	0.87	22	0.75	19	2.52	64	0.22	100
UL08F4	M22×1.5	1.06	27	0.87	22	2.76	70	0.32	145
UL10F4	M24×1.5	1.26	32	1.18	30	3.15	80	0.54	245
UL12F4	M30×1.5	1.42	36	1.18	30	3.43	87	0.68	310
UX12F4	M30×1.5	1.42	36	1.18	30	3.43	87	0.71	320
UL16F4	M33×1.5	1.61	41	1.42	36	3.94	100	1.05	475
UX16F4	M33×1.5	1.61	41	1.42	36	3.94	100	1.09	495

Standard product — Material: SS or SC equivalent steel, Surface: Zinc plating or chromate treatment

# Couplings UL / UX series

**F2**

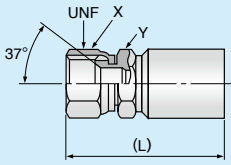

JIC 37° Female

Catalog Number	W Thread	X		Y		(L)		Weight	
		inch	mm	inch	mm	inch	mm	lbs	g
UL04F2	7/16-20	0.75	19	0.67	17	2.17	55	0.14	65
UL06F2	9/16-18	0.87	22	0.75	19	2.40	61	0.22	100
UL0608F2	3/4-16	1.06	27	0.87	22	2.56	65	0.30	135
UL08F2	3/4-16	1.06	27	0.87	22	2.64	67	0.33	150
UL0810F2	7/8-14	1.06	27	0.87	22	2.72	69	0.30	135
UL10F2	7/8-14	1.26	32	1.18	30	3.07	78	0.54	245
UL1012F2	1 1/16-12	1.42	36	1.18	30	3.11	79	0.61	275
UL12F2	1 1/16-12	1.42	36	1.18	30	3.23	82	0.71	320
UX12F2	1 1/16-12	1.42	36	1.18	30	3.27	83	0.72	325
UL16F2	1 5/16-12	1.61	41	1.42	36	3.62	92	0.98	445
UX16F2	1 5/16-12	1.61	41	1.42	36	3.62	92	1.01	460

**F2R4**

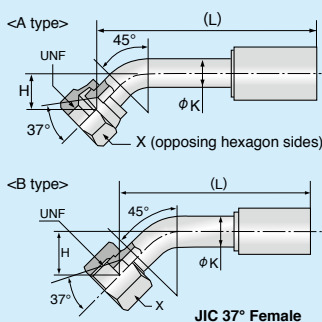

JIC 37° Female

Catalog Number	W Thread	Shape	X		H		(L)		Weight	
			inch	mm	inch	mm	inch	mm	lbs	g
UL04F2R422	7/16-20	A	0.59	19.0	0.55	13.7	3.03	77	0.15	70
UL06F2R437	9/16-18	A	0.87	22.0	0.98	24.9	3.62	92	0.28	125
UL0608F2R4N18	3/4-16	B	0.87	22.0	0.71	18.0	3.40	86	0.30	135
UL08F2R4N31	3/4-16	A	0.87	22.0	0.94	23.9	4.49	114	0.44	200
UL0810F2R405	7/8-14	B	1.26	32.0	1.38	35.0	4.65	118	0.44	200
UL10F2R4	7/8-14	B	0.98	25.4	0.87	22.0	3.70	94	0.46	210

**F2R9**

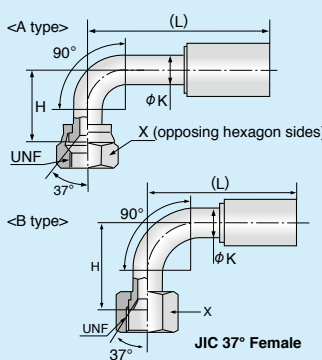

JIC 37° Female

Catalog Number	W Thread	Shape	X		H		(L)		Weight	
			inch	mm	inch	mm	inch	mm	lbs	g
UL04F2R9N25	7/16-20	A	0.75	19.0	0.98	25	2.60	66	0.17	75
UL06F2R914	9/16-18	A	0.87	22.0	1.18	30	2.99	76	0.28	125
UL0608F2R964	3/4-16	B	0.87	22	1.77	45	3.19	81	0.32	145
UL08F2R9N50	3/4-16	A	1.06	27	1.54	39	3.46	88	0.44	200
UL0810F2R911	7/8-14	B	1.00	25.4	2.56	65	3.07	78	0.44	200
UL10F2R9	7/8-14	B	1.00	25.4	1.73	44	3.35	85	0.47	215
UL12F2R9N78	1 1/16-12	B	1.42	36	3.07	78	4.13	105	1.10	500
UX12F2R9	1 1/16-12	B	1.25	31.8	2.09	53	3.94	100	0.74	335
UL16F2R9	1 5/16-12	B	1.50	38.0	2.48	63	4.25	108	1.12	510
UX16F2R9N63	1 5/16-12	B	1.50	38.1	2.48	63	4.25	108	1.17	530

**Q2**

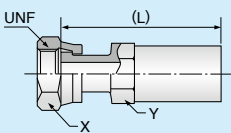

Female O-Ring Face Seal

Catalog Number	W Thread	X		Y		(L)		Weight	
		inch	mm	inch	mm	inch	mm	lbs	g
UL04Q2	9/16-18	0.75	19	0.67	17	2.24	57	0.15	70
UL04Q2C7	9/16-18	0.75	19	0.67	17	2.24	57	0.14	65
UL06Q2	1 1/16-16	0.87	22	0.75	19	2.48	63	0.24	110
UL06Q2C7	1 1/16-16	0.87	22	0.75	19	2.48	63	0.23	105
UL08Q2	1 3/16-16	1.06	27	0.87	22	2.76	67	0.34	155
UL08Q2C7	1 3/16-16	1.06	27	0.87	22	2.76	67	0.32	145
UL10Q2	1-14	1.26	32	1.18	30	3.07	78	0.58	265
UL10Q2H27	1-14	1.26	32	1.06	27	2.99	76	0.53	240
UL1012Q2	1 3/16-12	1.42	36	1.18	30	3.11	79	0.62	280
UL12Q2	1 3/16-12	1.42	36	1.18	30	3.23	82	0.15	330
UX12Q2	1 3/16-12	1.42	36	1.18	30	3.23	82	0.74	335
UL16Q2	1 7/16-12	1.61	41	1.42	36	3.74	95	1.08	490
UX16Q2	1 7/16-12	1.61	41	1.42	36	3.74	95	1.12	510

**Q2C7**

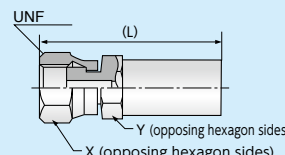

Short type Flat face

Catalog Number	W Thread	X		Y		(L)		Weight	
		inch	mm	inch	mm	inch	mm	lbs	g
UL04Q2C7	9/16-18	0.75	19	0.67	17	2.24	57	0.14	65
UL06Q2C7	11/16-16	0.87	22	0.75	19	2.48	63	0.23	105
UL08Q2C7	13/16-16	1.06	27	0.87	22	2.64	67	0.32	145
UL10Q2H27C7	1-14	1.26	32	1.06	27	3.07	78	0.51	230

Standard product — Material: SS or SC equivalent steel, Surface: Zinc plating or chromate treatment

## Q2R4

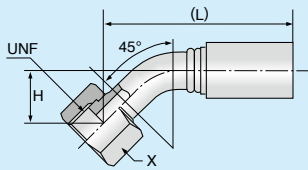

Female O-Ring Face Seal

Catalog Number	W Thread	X		H		(L)		Weight	
		inch	mm	inch	mm	inch	mm	lbs	g
UL04Q2R4	9/16-18	0.75	19	0.43	11	2.87	73	0.16	75
UL06Q2R4	1 1/16-12	0.87	22	0.83	21	3.50	89	0.30	135
UL08Q2R4N22	1 3/16-12	1.06	27	0.87	22	3.11	79	0.37	170
UL10Q2R4N26	1-14	1.26	32	1.02	26	3.82	97	0.61	275
UL1012Q2R408	1 3/16-12	1.42	36	1.02	26	4.02	102	0.66	300
UL12Q2R4	1 3/16-12	1.42	36	1.02	26	3.94	100	0.76	345
UX12Q2R4	1 3/16-12	1.42	36	1.02	26	3.86	98	0.78	355
UL16Q2R421	1 7/16-12	1.61	41	1.10	28	4.57	116	1.20	545
UX16Q2R4	1 7/16-12	1.61	41	1.18	30	4.80	122	1.22	555

## Q2R9

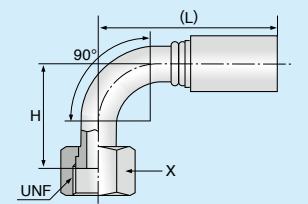

Female O-Ring Face Seal

Catalog Number	W Thread	X		H		(L)		Weight	
		inch	mm	inch	mm	inch	mm	lbs	g
UL04Q2R9	9/16-18	0.75	19	0.91	23	2.36	60	0.17	75
UL06Q2R9	1 1/16-12	0.87	22	1.29	38	2.64	67	0.30	135
UL08Q2R9	1 3/16-12	1.06	27	1.69	43	2.95	75	0.41	185
UL10Q2R9	1-14	1.26	32	2.17	55	3.62	92	0.68	310
UL1012Q2R9N58	1 3/16-12	1.42	36	1.02	26	3.58	91	0.75	340
UL12Q2R9	1 3/16-12	1.42	36	2.28	58	3.62	92	0.61	380
UX12Q2R9	1 3/16-12	1.42	36	2.28	58	3.58	91	0.85	385
UL16Q2R9	1 7/16-12	1.61	41	2.64	67	4.49	114	1.33	605
UX16Q2R9	1 7/16-12	1.61	41	2.64	67	4.49	114	1.37	620

## K

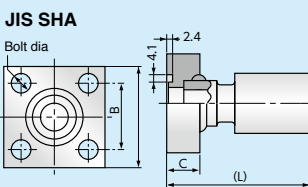

JIS B 2291 21MPa (210kgf/cm<sup>2</sup>) Flange

Catalog Number	A φ		B		C		(L)		Bolt	Bolt dia		Weight	
	inch	mm	inch	mm	inch	mm	inch	mm		inch	mm	lbs	g
UL08K15	2.48	63	1.57	40	0.87	22	3.11	79	M10	0.43	11	1.50	680
UL12K20	2.68	68	1.77	45	0.87	22	3.62	92	M10	0.43	11	1.85	840
UX12K20	2.68	68	1.77	45	0.87	22	3.62	92	M10	0.43	11	2.03	920
UL16K25	3.15	80	2.09	53	1.10	28	3.90	99	M12	0.51	13	3.44	1,560
UX16K25	3.15	80	2.09	53	1.10	28	3.90	99	M12	0.51	13	3.47	1,575

## K2

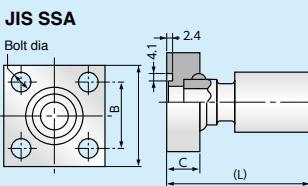

JIS B 2291 21MPa (210kgf/cm<sup>2</sup>) Flange

Catalog Number	A φ		B		C		(L)		Bolt	Bolt dia		Weight	
	inch	mm	inch	mm	inch	mm	inch	mm		inch	mm	lbs	g
UL08K215	2.13	54	1.42	36	0.87	22	3.11	79	M10	0.43	11	1.10	500
UL12K220	2.28	58	1.57	40	0.87	22	3.62	92	M10	0.43	11	1.44	655
UX12K220	2.28	58	1.57	40	0.87	22	3.62	92	M10	0.43	11	1.54	700
UL16K225	2.68	68	1.89	48	1.10	28	3.90	99	M12	0.51	13	2.36	1,070
UX16K225	2.68	68	1.89	48	1.10	28	3.90	99	M12	0.51	13	2.76	1,250

Standard product — Material: SS or SC equivalent steel, Surface: Zinc plating or chromate treatment

# Couplings UB / UZ series

**R**

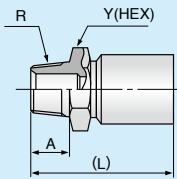

Male British Tapered Pipe Thread (BSPT)

Catalog Number	W Thread	Y		A		(L)		Weight	
		inch	mm	inch	mm	inch	mm	lbs	g
UZ04R	1/4	0.67	17	0.51	13	1.97	50	0.11	50
UB06R	3/8	0.75	19	0.59	15	2.28	58	0.19	85
UB08R	1/2	0.87	22	0.71	18	2.52	64	0.28	125
UZ08R	1/2	0.87	22	0.71	18	2.52	64	0.28	125
UB1012R	3/4	1.18	30	0.79	20	3.07	78	0.49	220
UB12R	3/4	1.18	30	0.79	20	3.35	85	0.63	285
UB16R	1	1.42	36	0.87	22	3.66	93	0.95	430
UZ20R	1 1/4	1.81	46	0.99	25.2	4.80	122	1.91	865

**F**

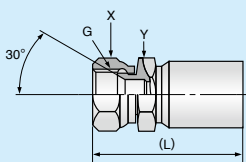

Female Japanese Industrial Pipe Thread (JIS) Female 30° Seat

Catalog Number	W Thread	X		Y		(L)		Weight	
		inch	mm	inch	mm	inch	mm	lbs	g
UZ04F	1/4	0.75	19	0.67	17	0.12	56	0.15	70
UB06F	3/8	0.87	22	0.75	19	0.14	62	0.22	100
UB08F	1/2	1.06	27	0.87	22	0.15	67	0.32	145
UZ08F	1/2	1.06	27	0.87	22	2.64	67	0.32	145
UB1012F	3/4	1.42	36	1.18	30	0.18	83	0.64	290
UB12F	3/4	1.42	36	1.18	30	0.20	91	0.79	360
UB16F	1	1.61	41	1.42	36	0.22	99	1.14	515
UZ20F	1 1/4	1.97	50	1.81	46	5.04	128	2.13	965

**C**

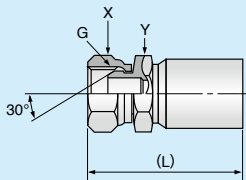

Female British Parallel Pipe Thread Male 30° Seat (BSPOR)

Catalog Number	W Thread	X		Y		(L)		Weight	
		inch	mm	inch	mm	inch	mm	lbs	g
UZ04C	1/4	0.75	19	0.67	17	2.20	56	0.15	70
UB06C	3/8	0.87	22	0.75	19	2.44	62	0.23	105
UB08C	1/2	1.06	27	0.87	22	2.64	67	0.33	150
UZ08C	1/2	1.06	27	0.87	22	2.64	67	0.33	150
UB1012C	3/4	1.42	36	1.18	30	3.27	83	0.65	295
UB1008CH27	1/2	1.06	27	1.06	27	3.03	77	0.46	210
UB12C	3/4	1.42	36	1.18	30	3.54	91	0.80	365
UB16C	1	1.61	41	1.42	36	3.90	99	1.15	520
UZ20C	1 1/4	1.97	50	1.81	46	5.04	128	2.16	980

**CR4**

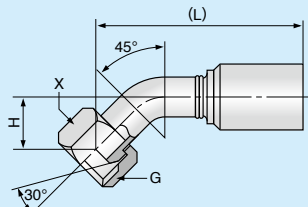

Female British Parallel Pipe Thread Male 30° Seat (BSPOR)

Catalog Number	W Thread	X		H		(L)		Weight	
		inch	mm	inch	mm	inch	mm	lbs	g
UZ04CR4	1/4	0.75	19	0.94	24	3.03	77	0.17	75
UB06CR4	3/8	0.87	22	1.02	26	3.43	87	0.28	125
UB08CR4	1/2	1.06	27	0.87	22	4.72	120	0.46	210
UZ08CR4	1/2	1.06	27	0.87	22	4.41	112	0.46	210
UB1012CR4	3/4	1.42	36	1.14	29	3.98	101	0.76	345
UB12CR4	3/4	1.42	36	1.14	29	4.41	112	0.91	415
UB16CR4	1	1.61	41	1.30	33	5.16	131	1.41	640
UZ20CR4	1 1/4	1.97	50	1.49	37.9	6.30	160	2.66	1,205

**CR6**

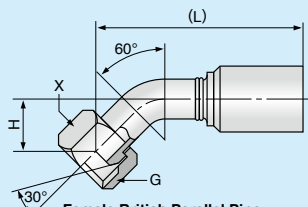

Female British Parallel Pipe Thread Male 30° Seat (BSPOR)

Catalog Number	W Thread	X		H		(L)		Weight	
		inch	mm	inch	mm	inch	mm	lbs	g
UZ04CR6N16	1/4	0.75	19	0.63	16	2.64	67	0.18	80
UB06CR6N27	3/8	0.87	22	1.06	27	3.31	84	0.26	120

**CR9**

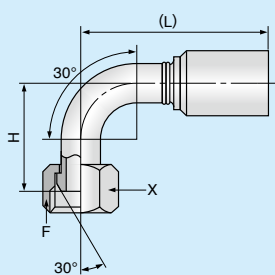

Female British Parallel Pipe Thread Male 30° Seat (BSPOR)

Catalog Number	W Thread	X		H		(L)		Weight	
		inch	mm	inch	mm	inch	mm	lbs	g
UZ04CR9	1/4	0.75	19	0.94	24	2.36	60	0.17	75
UB06CR9	3/8	0.87	22	1.50	38	2.64	67	0.28	125
UB08CR9	1/2	1.06	27	1.81	46	3.70	94	0.46	210
UZ08CR9	1/2	1.06	27	1.81	46	3.39	86	0.46	210
UB1012CR9	3/4	1.42	36	2.36	60	3.74	95	0.84	380
UB12CR9	3/4	1.42	36	2.36	60	4.02	102	0.98	445
UB16CR9	1	1.61	41	2.76	70	4.72	120	1.55	705
UZ20CR9	1 1/4	1.97	50	3.15	80	5.83	148	2.92	1,325

# S

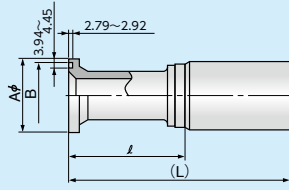

Flange Head S CODE 61 Flange

Catalog Number	Aφ		B		φ		(L)		Weight	
	inch	mm	inch	mm	inch	mm	inch	mm	lbs	g
UB08S	1.18	30	1.02	26	1.38	35	2.83	72	0.30	135
UB0812S	1.50	38	1.26	32	1.42	36	2.87	73	0.35	160
UZ08S	1.19	30.20	1.005~1.000	25.53~25.40	1.38	35	2.83	72	0.31	140
UB1012S	1.50	38	1.26	32	1.38	35	3.27	83	0.51	230
UB12S	1.50	38	1.26	32	1.38	35	3.54	90	0.67	305
UB1208S	1.18	30	0.98	25	1.81	46	4.02	102	0.64	290
UB1216S	1.77	45	1.57	40	1.38	35	3.54	90	0.73	330
UB16S	1.73	44	1.57	40	1.38	35	3.66	93	0.96	435
UB1612S	1.50	38	1.26	32	1.38	35	3.66	93	0.89	405
UB1620S	2.01	51	1.77	45	1.38	35	3.66	93	1.01	460
UB20S	2.00	50.80	1.755~1.750	44.58~44.45	1.74	44.1	4.84	123	2.09	950
UZ20S	2.00	50.80	1.755~1.750	44.58~44.45	1.62	41.1	4.84	123	2.00	905

# SR4

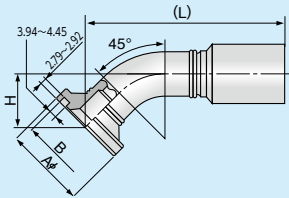

Flange Head S CODE 61 Flange

Catalog Number	Aφ		B		H		(L)		Weight	
	inch	mm	inch	mm	inch	mm	inch	mm	lbs	g
UB08SR4	1.18	30	0.98	25	0.79	20	3.03	77	0.32	145
UB0812SR4N28	1.50	38	1.26	32	1.10	28	2.44	62	0.44	200
UB1008SR4N28	1.18	30	0.98	25	1.10	28	3.90	99	0.49	220
UZ08SR4	1.19	30.20	1.005~1.000	25.53~25.40	0.79	20	3.03	77	0.32	145
UB1012SR4	1.50	38	1.26	32	0.98	25	4.57	116	0.67	305
UB12SR4	1.50	38	1.26	32	0.98	25	4.25	108	0.77	350
UB12SR4N52	1.50	38	1.26	32	2.05	52	5.55	141	0.93	420
UB1208SR4N25	1.18	30	0.98	25	0.98	25	4.33	110	0.68	310
UB1216SR4N28	1.77	45	1.57	40	1.10	28	4.49	114	0.86	390
UB16SR4	1.73	44	1.57	40	1.10	28	4.61	117	1.16	525
UB16SR4N40	1.77	45	1.57	40	1.57	40	5.08	129	1.22	555
UB1612SR4N52	1.50	38	1.26	32	2.05	52	5.87	149	1.27	575
UB1620SR4N28	2.01	51	1.77	45	1.10	28	4.61	117	1.21	550
UB20SR4	2.00	50.80	1.755~1.750	44.58~44.45	1.18	30	5.63	143	2.05	930
UZ20SR4	2.00	50.80	1.755~1.750	44.58~44.45	1.18	30	5.63	143	1.96	890

# SR9

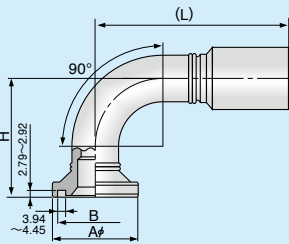

Flange Head S CODE 61 Flange

Catalog Number	Aφ		B		H		(L)		Weight	
	inch	mm	inch	mm	inch	mm	inch	mm	lbs	g
UB08SR9	1.18	30	0.98	25	1.61	41	2.83	72	0.35	160
UB0812SR9N55	1.50	38	1.25	32	2.17	55	3.39	86	0.47	215
UB1008SR9	1.18	30	1.00	25	1.65	42	3.27	83	0.47	215
UB08SR970	1.19	30.20	1.005~1.000	25.53~25.40	3.54	90	3.43	87	0.68	310
UB08SR9N60	1.19	30.20	1.005~1.000	25.53~25.40	2.36	60	3.39	86	0.43	195
UZ08SR9	1.19	30.20	1.005~1.000	25.53~25.40	1.61	41	2.83	72	0.35	160
UB1012SR9	1.50	38	1.25	32	2.13	54	3.66	93	0.64	290
UB1008SR9N90	1.19	30.20	1.005~1.000	25.53~25.40	3.54	90	3.27	83	0.58	265
UB12SR9	1.50	38	1.25	32	2.13	54	3.98	101	0.86	390
UB12SR9N100	1.50	38	1.25	32	3.94	100	5.55	141	1.18	535
UB12SR9N150	1.50	38	1.56	40	5.91	150	5.55	141	1.36	615
UB1208SR9N52	1.18	30	1.00	25	2.05	52	3.94	100	0.73	330
UB1216SR9	1.73	44	1.56	40	2.36	60	3.98	101	0.94	425
UB1216SR9N90	1.77	45	1.56	40	3.54	90	3.98	101	1.05	475
UB12SR9N150	1.50	38.10	1.255~1.250	31.88~31.75	5.91	150	5.55	141	1.36	615
UB16SR9	1.73	44	1.56	40	2.36	60	4.45	113	1.27	575
UB16SR9N98	1.77	45	1.56	40	3.86	98	4.45	113	1.48	670
UB16SR9N120	1.77	45	1.56	40	4.72	120	4.45	113	1.58	715
UB1612SR9N60	1.50	38	1.25	32	2.36	60	4.45	113	1.19	540
UB1620SR9	2.01	51	1.73	44	2.64	67	4.49	114	1.38	625
UB16SR9N90	1.75	44.45	1.565~1.560	39.75~39.62	3.54	90	4.45	113	1.43	650
UB20SR9	2.00	50.80	1.755~1.750	44.58~44.45	2.64	67	5.75	146	2.37	1,075
UZ20SR9	2.00	50.80	1.755~1.750	44.58~44.45	2.64	67	5.75	146	2.28	1,035

# H

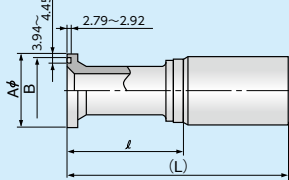

Flange Head H CODE 62 Flange

Catalog Number	Aφ		B		φ		(L)		Weight	
	inch	mm	inch	mm	inch	mm	inch	mm	lbs	g
UB08H	1.26	32	1.02	26	1.57	40	2.99	76	0.37	170
UB1012H	1.61	41	1.26	32	1.38	35	2.87	73	0.53	240
UB12H	1.61	41	1.26	32	1.38	35	3.54	90	0.71	320
UB1216H	1.89	48	1.57	40	1.65	42	3.82	97	0.85	385
UB16H	1.89	48	1.57	40	1.50	38	3.82	97	1.06	480
UB1612H	1.50	38	1.26	32	1.34	34	3.62	92	0.94	425
UB1620H	2.13	54	1.77	45	1.65	42	3.94	100	1.20	545
UB20H	2.13	53.98	1.755~1.750	44.58~44.45	2.00	50.8	5.12	130	2.40	1,090
UZ20H	2.13	53.98	1.755~1.750	44.58~44.45	2.00	50.8	5.12	130	2.31	1,050

# Couplings UB / UZ series

**HR4**

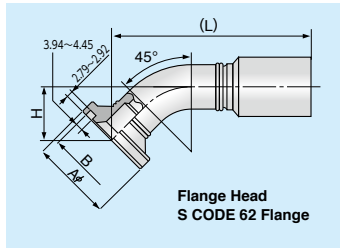

Catalog Number	Aφ		B		H		(L)		Weight	
	inch	mm	inch	mm	inch	mm	inch	mm	lbs	g
UB08HR4	1.26	32	0.94	24	0.83	21	3.11	79	0.35	160
UB12HR4	1.61	41	1.26	32	1.02	26	4.33	110	0.83	375
UB1216HR4N52	1.89	48	1.57	40	2.05	52	5.04	128	1.11	505
UB16HR4	1.89	48	1.57	40	1.34	34	5.00	127	1.25	565
UB1620HR4N40	2.13	54	1.77	45	1.57	40	5.87	149	1.91	865
UB20HR4	2.13	53.98	1.755~1.750	44.58~44.45	1.38	35	6.22	158	2.74	1,245
UZ20HR4	2.13	53.98	1.755~1.750	44.58~44.45	1.38	35	6.22	158	2.66	1,205

**HR9**

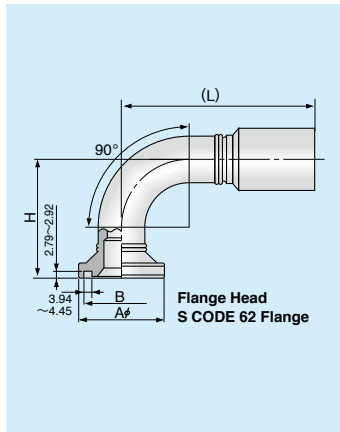

Catalog Number	Aφ		B		H		(L)		Weight	
	inch	mm	inch	mm	inch	mm	inch	mm	lbs	g
UB08HR9	1.26	32	0.98	25	1.69	43	2.83	72	0.39	175
UB1012HR9N55	1.61	41	1.26	32	2.17	55	3.98	101	0.73	330
UB1012HR9	1.63	41.28	1.255~1.250	31.88~31.75	2.28	58	3.98	101	0.74	335
UB12HR9	1.61	41	1.26	32	2.28	58	3.98	101	0.90	410
UB12HR9N100	1.61	41	1.26	32	3.94	100	4.06	103	1.09	495
UB1216HR9N73	1.89	48	1.57	40	2.87	73	4.33	110	1.12	510
UB16HR9	1.89	48	1.57	40	2.87	73	4.45	113	1.41	640
UB16HR9N90	1.89	48	1.57	40	3.54	90	4.45	113	1.51	685
UB16HR9N115	1.89	48	1.57	40	4.53	115	4.45	113	1.63	740
UB1620HR9N66	2.13	54	1.77	45	2.60	66	4.45	113	1.52	690
UB1620HR9N90	2.13	54	1.77	45	3.54	90	4.45	113	1.64	745
UB16HR917	1.88	47.63	1.565~1.560	39.75~39.62	3.94	100	4.57	116	1.75	795
UB20HR9	2.13	53.98	1.565~1.560	44.58~44.45	3.90	99	6.02	153	3.16	1,435
UZ20HR9	2.13	53.98	1.565~1.560	44.58~44.45	3.90	99	6.02	153	3.06	1,390

**G**

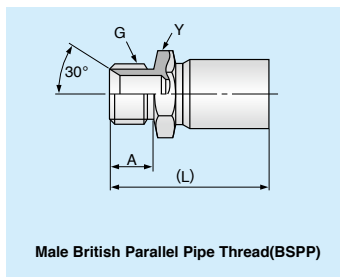

Catalog Number	Thread	Y		A		(L)		Weight	
		inch	mm	inch	mm	inch	mm	lbs	g
UZ04G	1/4	0.67	17	0.51	13	1.97	50	0.11	50
UB06G	3/8	0.75	19	0.59	15	2.28	58	0.19	85
UB08G	1/2	0.87	22	0.71	18	2.52	64	0.26	120
UZ08G	1/2	0.87	22	0.71	18	2.52	64	0.26	120
UB1012G	3/4	1.18	30	0.79	20	3.07	78	0.47	215
UB12G	3/4	1.18	30	0.79	20	3.35	85	0.62	280
UB16G	1	1.42	36	0.87	22	3.66	93	0.94	425
UZ20G	1 1/4	1.81	46	0.99	25.2	4.80	122	1.90	860

**F4**

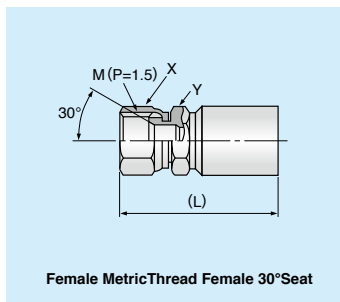

Catalog Number	Thread	X		Y		(L)		Weight	
		inch	mm	inch	mm	inch	mm	lbs	g
UZ04F4	M14x1.5	0.75	19	0.67	17	2.24	57	0.15	70
UB06F4U24	M18x1.5	0.94	24	0.75	19	2.52	64	0.24	110
UB06F4	M18x1.5	0.87	22	0.75	19	2.52	64	0.22	100
UB08F4	M22x1.5	1.06	27	0.87	22	2.76	70	0.33	150
UZ08F4	M22x1.5	1.06	27	0.87	22	2.76	70	0.33	150
UB10F4	M24x1.5	1.26	32	1.18	30	3.31	84	0.60	270
UB12F4	M30x1.5	1.42	36	1.18	30	3.74	95	0.78	355
UB16F4	M33x1.5	1.61	41	1.61	41	4.17	106	1.20	545
UZ20F4	M36x1.5	1.97	50	1.81	46	5.12	130	1.76	800

**F2**

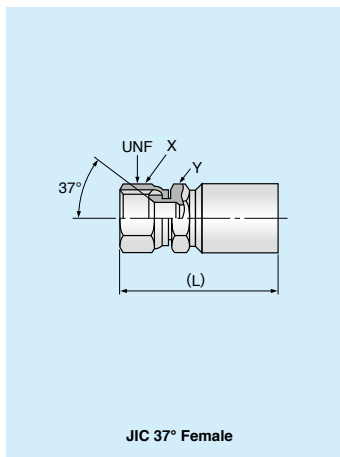

Catalog Number	Thread	X		Y		(L)		Weight	
		inch	mm	inch	mm	inch	mm	lbs	g
UZ04F2	7/16-20	0.75	19	0.67	17	2.17	55	0.14	65
UZ0406F2	9/16-18	0.87	22	0.75	19	2.32	59	0.19	85
UB06F2	9/16-18	0.87	22	0.75	19	2.44	62	0.23	105
UB0608F2	3/4-16	1.06	27	0.87	22	2.56	65	0.31	140
UB08F2	3/4-16	1.06	27	0.87	22	2.64	67	0.35	160
UB0810F2	7/8-14	1.06	27	0.87	22	2.72	69	0.40	145
UZ08F2	3/4-16	1.06	27	0.87	22	2.64	67	0.35	160
UZ0810F2	7/8-14	1.06	27	0.87	22	2.72	69	0.40	145
UB0812F2	1 1/16-12	1.42	36	1.18	30	2.95	75	0.57	260
UB10F2	7/8-14	1.26	32	1.18	30	3.19	81	0.59	270
UB1012F2	1 1/16-12	1.42	36	1.18	30	3.27	83	0.66	300
UB12F2	1 1/16-12	1.42	36	1.18	30	3.58	91	0.79	360
UB16F2	1 5/16-12	1.61	41	1.42	36	3.86	98	1.12	510
UB1612F2	1 1/16-12	1.42	36	1.42	36	3.70	94	1.08	490
UZ20F2	1 5/8-12	1.97	50	1.81	46	5.04	128	2.13	965

Standard product — Material: SS or SC equivalent steel, Surface: Zinc plating or chromate treatment

## F2R4

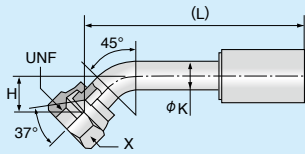

JIC 37° Female

Catalog Number	Thread	X		H		(L)		Weight	
		inch	mm	inch	mm	inch	mm	lbs	g
UZ04F2R422	7/16-20	0.75	19	0.55	14	3.03	77	0.15	70
UB06F2R437	9/16-18	0.87	22	0.87	22	3.62	92	0.29	130
UB08F2R4N18	3/4-16	1.06	27	0.71	18	4.25	108	0.44	200
UB08F2R4N23	3/4-16	0.87	22	0.94	24	4.49	114	0.44	200
UZ08F2R4N18	3/4-16	1.06	27	0.71	18	4.25	108	0.44	200
UZ08F2R4N23	3/4-16	0.87	22	0.94	23.9	4.49	114	0.44	200
UB12F2R4N45	1 1/16-12	1.42	36	1.38	35	5.04	128	1.11	505
UB16F2R409	1 5/16-12	1.61	41	1.57	40	5.87	149	1.91	865
UZ20F2R4N38	1 5/8-12	2.00	50.8	1.50	38.2	7.83	199	3.04	1,380

## F2R9

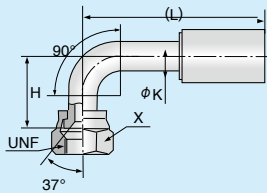

JIC 37° Female

Catalog Number	Thread	X		H		(L)		Weight	
		inch	mm	inch	mm	inch	mm	lbs	g
UZ04F2R9N25	7/16-20	0.75	19	0.98	25	2.60	66	0.17	75
UB06F2R914	9/16-18	0.87	22	1.18	30	3.46	88	0.28	125
UB08F2R9N39	3/4-16	1.06	27	1.54	39	3.70	94	0.35	160
UZ08F2R9N39	3/4-16	1.06	27	1.54	39.2	3.70	94	0.35	160
UB08F2R9N50	3/4-16	1.06	27	1.54	39	3.50	89	0.35	160
UZ08F2R9N50	3/4-16	1.06	27	1.54	39	3.50	89	0.47	215
UB0810F2R986	7/18-14	1.06	27	2.17	55	3.70	94	0.51	230
UB10F2R931	7/8-14	1.06	27	2.36	60	3.46	88	0.58	265
UB12F2R9N78	1 1/16-12	1.42	36	2.52	64	4.45	113	1.20	545
UB16F2R9	1 5/16-12	1.50	38	2.48	63	4.49	114	1.28	580
UZ20F2R9N78	1 5/8-12	2.00	50.8	3.07	78	6.89	175	3.13	1,420

## R1

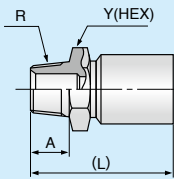

NPTF Male

Catalog Number	Thread	Y		A		(L)		Weight	
		inch	mm	inch	mm	inch	mm	lbs	g
UZ04R1	1/4	0.67	17	0.56	14.3	2.05	52	0.11	50
UB0406R1	3/8	0.75	19	0.56	14.3	2.13	54	0.14	65
UB06R1	3/8	0.75	19	0.56	14.3	2.24	57	0.19	85
UB0608R1	1/2	0.87	22	0.75	19.0	2.48	63	0.24	110
UB08R1	1/2	0.87	22	0.75	19.0	2.56	65	0.28	125
UB1012R1	3/4	1.18	30	0.75	19.0	2.87	73	0.49	220
UB12R1	3/4	1.18	30	0.75	19.0	2.99	76	0.63	285
UB16R1	1	1.42	36	0.94	23.9	3.50	89	0.97	440

## Q

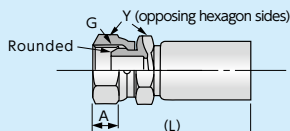

Equipped with safety hole

Catalog Number	Thread	Y		A		(L)		Weight	
		inch	mm	inch	mm	inch	mm	lbs	g
UB08Q	1/2	1.06	27	0.43	11	2.64	67	0.37	170

## Q2

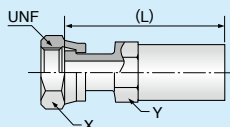

Female O-Ring Face Seal

Catalog Number	Thread	X		Y		(L)		Weight	
		inch	mm	inch	mm	inch	mm	lbs	g
UZ04Q2	9/16-18	0.75	19	0.67	17	2.24	57	0.17	75
UZ04Q2C7	9/16-18	0.75	19	0.67	17	2.24	57	0.15	70
UB06Q2	11/16-16	0.87	22	0.75	19	2.48	63	0.25	115
UB06Q2C7	11/16-16	0.87	22	0.75	19	2.48	63	0.23	105
UB08Q2	13/16-16	1.06	27	0.87	22	2.64	67	0.36	165
UB08Q2C7	13/16-16	1.06	27	0.87	22	2.64	67	0.34	155
UZ08Q2	13/16-16	1.06	27	0.87	22	2.64	67	0.36	165
UB10Q2	1-14	1.26	32	1.18	30	3.23	82	0.63	285
UB10Q2H27	1-14	1.26	32	1.06	27	3.15	80	0.58	265
UB1012Q2	1 3/16-12	1.42	36	1.18	30	3.23	82	0.67	305
UB12Q2	1 3/16-12	1.42	36	1.18	30	3.54	90	0.83	375
UB1216Q2	1 7/16-12	1.61	41	1.42	36	3.86	98	1.04	470
UB16Q2	1 7/16-12	1.61	41	1.42	36	3.98	101	1.23	560
UZ20Q2	1 11/16-12	1.97	50	1.81	46	4.92	125	2.34	1,060
UB20Q2	1 11/16-12	1.97	50	1.97	50	5.16	131	3.00	1,360

## Q2C7

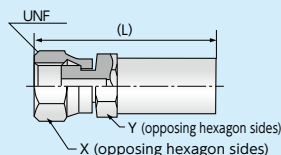

Short type Flat face

Catalog Number	Thread	X		Y		(L)		Weight	
		inch	mm	inch	mm	inch	mm	lbs	g
UZ04Q2C7	9/16-18	0.75	19	0.67	17	2.24	57	0.15	70
UB06Q2C7	11/16-16	0.87	22	0.75	19	2.48	63	0.23	105
UB08Q2C7	13/16-16	1.06	27	0.87	22	2.64	67	0.34	155
UZ08Q2C7	13/16-16	1.06	27	0.87	22	2.64	67	0.34	155
UB10Q2H27C7	1-14	1.26	32	1.06	27	3.23	82	0.56	255

Standard product — Material: SS or SC equivalent steel, Surface: Zinc plating or chromate treatment

# Couplings UB / UZ series

## Q2R4

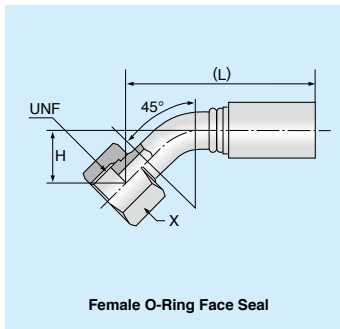

Catalog Number	W Thread	X		H		(L)		Weight	
		inch	mm	inch	mm	inch	mm	lbs	g
UZ04Q2R4	9/16-18	0.75	19	0.43	11	2.87	73	0.17	75
UB06Q2R4	11/16-16	0.87	22	0.83	21	3.50	89	0.31	140
UB08Q2R4	13/16-16	1.06	27	0.87	22	3.11	79	0.39	175
UZ08Q2R4N22	13/16-16	1.06	27	0.87	22	3.11	79	0.39	175
UB10Q2R4N26	1-14	1.26	32	1.02	26	0.43	11	0.66	300
UB1012Q2R408	1 3/16-12	1.42	36	1.02	26	4.17	106	0.72	325
UB12Q2R4	1 3/16-12	1.26	36	1.02	26	4.17	106	0.86	390
UB16Q2R4	1 7/16-12	1.61	41	1.18	30	5.04	128	1.33	605
UB20Q2R4N40	1 11/16-12	1.97	50	1.57	40	6.22	158	2.29	1,040
UZ20Q2R4	1 11/16-12	1.97	50	1.57	40	6.22	158	2.67	1,210

## Q2R9

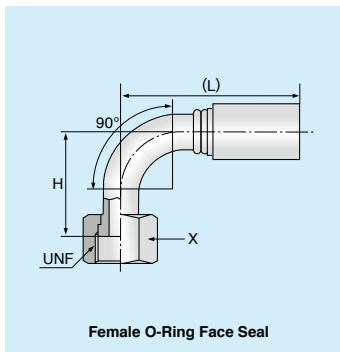

Catalog Number	W Thread	X		H		(L)		Weight	
		inch	mm	inch	mm	inch	mm	lbs	g
UZ04Q2R9	9/16-18	0.75	19	0.91	23	2.36	60	0.18	80
UB06Q2R9	11/16-16	0.87	22	1.50	38	2.64	67	0.31	140
UB08Q2R9	13/16-16	1.06	27	1.69	43	2.95	75	0.43	195
UZ08Q2R9	13/16-16	1.06	27	1.69	43	2.95	75	0.43	195
UB10Q2R9	1-14	1.26	32	2.17	55	3.78	96	0.73	330
UB1012Q2R9N58	1 3/16-12	1.42	36	2.28	58	3.70	94	0.80	365
UB12Q2R9	1 3/16-12	1.42	36	2.28	58	3.90	99	0.94	425
UB12Q2R9N73	1 3/16-12	1.42	36	2.87	73	3.90	99	0.97	440
UB16Q2R9	1 7/16-12	1.61	41	2.64	67	4.72	120	1.48	670
UB20Q2R9N100	1 11/16-12	1.97	50	3.94	100	6.02	153	2.43	1,100
UZ20Q2R9	1 11/16-12	1.97	50	2.91	74	6.02	153	2.93	1,330

## K

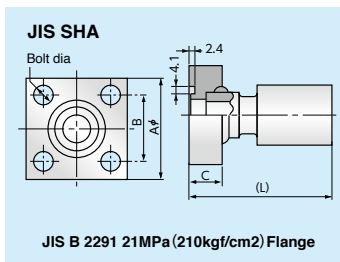

Catalog Number	Aφ		B		C		(L)		Bolt	Bolt dia		Weight	
	inch	mm	inch	mm	inch	mm	inch	mm		inch	mm	lbs	g
UB08K15	2.48	63	1.57	40	0.87	22	3.11	79	M10	0.43	11	1.52	690
UZ08K15	2.48	63	1.57	40	0.87	22	3.11	79	M10	0.43	11	1.52	690
UB12K20	2.68	68	1.77	45	0.87	22	3.94	100	M10	0.43	11	2.03	920
UB16K25	3.15	80	2.09	53	1.10	28	4.13	105	M12	0.51	13	3.58	1,625
UB20K32	3.54	90	2.48	63	1.10	28	5.43	138	M12	0.51	13	5.36	2,430
UZ20K32	3.54	90	2.48	63	1.10	28	5.43	138	M12	0.51	13	5.27	2,390

## K1

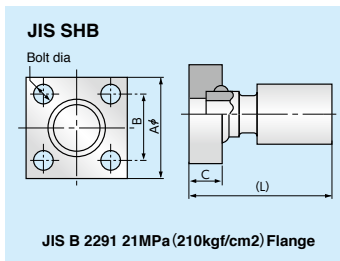

Catalog Number	Aφ		B		C		(L)		Bolt	Bolt dia		Weight	
	inch	mm	inch	mm	inch	mm	inch	mm		inch	mm	lbs	g
UB08K115	2.48	63	1.57	40	0.87	22	3.11	79	M10	0.43	11	1.52	690
UZ08K115	2.48	63	1.57	40	0.87	22	3.11	79	M10	0.43	11	1.52	690
UB12K120	2.68	68	1.77	45	0.87	22	3.94	100	M12	0.51	13	2.09	950
UB16K125	3.15	80	2.09	53	1.10	28	4.13	105	M12	0.51	13	3.40	1,540
UB20K132	3.54	90	2.48	63	1.10	28	5.43	138	M12	0.51	13	5.40	2,450
UZ20K132	3.54	90	2.48	63	1.10	28	5.43	138	M12	0.51	13	5.29	2,400

## K2

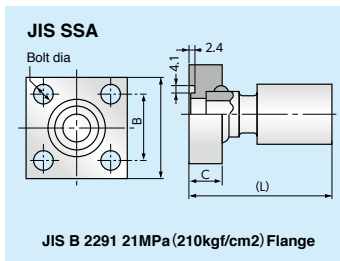

Catalog Number	Aφ		B		C		(L)		Bolt	Bolt dia		Weight	
	inch	mm	inch	mm	inch	mm	inch	mm		inch	mm	lbs	g
UB08K215	2.13	54	1.42	36	0.87	22	3.11	79	M10	0.43	11	1.37	620
UZ08K215	2.13	54	1.42	36	0.87	22	3.11	79	M10	0.43	11	1.37	620
UB12K220	2.28	58	1.57	40	0.87	22	3.94	100	M10	0.43	11	1.54	700
UB16K225	2.68	68	1.89	48	1.10	28	4.13	105	M12	0.51	13	2.51	1,140
UB20K232	2.99	76	2.20	56	1.10	28	5.43	138	M12	0.51	13	4.28	1,940
UZ20K232	2.99	76	2.20	56	1.10	28	5.43	138	M12	0.51	13	4.19	1,900

## K3

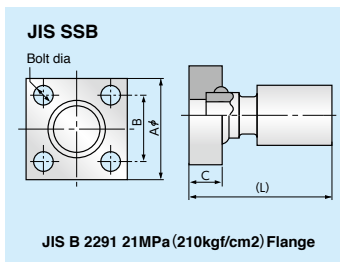

Catalog Number	Aφ		B		C		(L)		Bolt	Weight	
	inch	mm	inch	mm	inch	mm	inch	mm		lbs	g
UB08K315	2.13	54	1.42	36	0.87	22	3.11	79	M10	1.21	550
UZ08K315	2.13	54	1.42	36	0.87	22	3.11	79	M10	1.21	550
UB12K320	2.28	58	1.57	40	0.87	22	3.94	100	M10	1.68	760
UB16K325	2.68	68	1.89	48	1.10	28	4.13	105	M12	2.62	1,190
UB20K332	2.99	76	2.20	56	1.10	28	5.43	138	M12	4.37	1,980
UZ20K332	2.99	76	2.20	56	1.10	28	5.43	138	M12	4.25	1,930

Standard product — Material: SS or SC equivalent steel, Surface: Zinc plating or chromate treatment



# K4

## JIS LSA

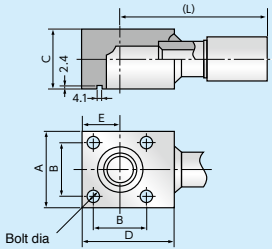

JIS B 2291 20.5MPa Tube Flange

Catalog Number	A $\phi$		B		C		D		E		(L)		Bolt	Bolt dia		Weight	
	inch	mm	inch	mm	inch	mm	inch	mm	inch	mm	inch	mm		inch	mm	inch	mm
<b>UB08K415</b>	2.13	54	1.42	36	1.57	40	2.48	63	1.06	27	3.66	93	M10	0.43	11	2.09	950
<b>UZ08K415</b>	2.13	54	1.42	36	1.57	40	2.48	63	1.06	27	3.66	93	M10	0.43	11	2.09	950
<b>UB12K420</b>	2.28	58	1.57	40	1.77	45	2.76	70	1.14	29	4.69	119	M10	0.43	11	3.13	1,420
<b>UB16K425</b>	2.68	68	1.89	48	1.97	50	3.23	82	1.34	34	4.92	125	M12	0.51	13	4.50	2,040
<b>UB20K432</b>	2.99	76	2.20	56	2.48	63	3.62	92	1.50	38	6.46	164	M12	0.51	13	7.80	3,540
<b>UZ20K432</b>	2.99	76	2.20	56	2.48	63	3.62	92	1.50	38	6.46	164	M12	0.51	13	7.69	3,490

# KR9

## JIS SHA

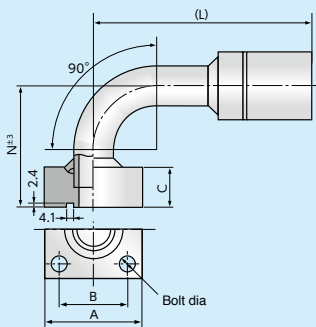

JIS B 2291 20.5MPa Tube Flange

Catalog Number	A $\phi$		B		C		N		(L)		Bolt	Bolt dia		Weight	
	inch	mm	inch	mm	inch	mm	inch	mm	inch	mm		inch	mm	inch	mm
<b>UB08K15R9N67</b>	2.48	63	1.57	40	0.87	22	2.64	67	4.76	121	M10	0.43	11	1.98	900
<b>UZ08K15R9N67</b>	2.48	63	1.57	40	0.87	22	2.64	67	4.76	121	M10	0.43	11	1.98	900
<b>UB12K20R9N75</b>	2.68	68	1.77	45	0.87	22	2.95	75	6.06	154	M10	0.43	11	2.98	1,350
<b>UB16K25R9N93</b>	3.15	80	2.09	53	1.10	28	3.66	93	6.93	176	M12	0.51	13	4.81	2,180
<b>UB20K32R9</b>	3.54	90	2.48	63	1.10	28	4.25	108	8.58	218	M12	0.51	13	7.41	3,360
<b>UZ20K32R9N108</b>	3.54	90	2.48	63	1.10	28	4.25	108	8.58	218	M12	0.51	13	7.30	3,310

# K1R9

## JIS SHA

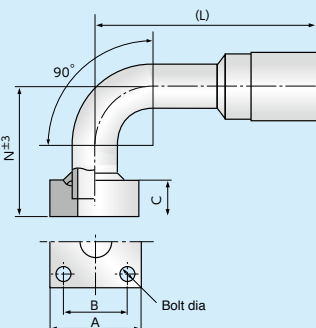

JIS B 2291 20.5MPa Tube Flange

Catalog Number	A $\phi$		B		C		N		(L)		Bolt	Bolt dia		Weight	
	inch	mm	inch	mm	inch	mm	inch	mm	inch	mm		inch	mm	inch	mm
<b>UB08K115R928</b>	2.48	63	1.57	40	0.87	22	2.64	67	4.76	121	M10	0.43	11	1.96	890
<b>UZ08K115R928</b>	2.48	63	1.57	40	0.87	22	2.64	67	4.76	121	M10	0.43	11	1.96	890
<b>UB12K120R9N75</b>	2.68	68	1.77	45	0.87	22	2.95	75	6.06	154	M12	0.51	13	3.13	1,420
<b>UB16K125R9N100</b>	3.15	80	2.09	53	1.10	28	3.94	100	6.93	176	M12	0.51	13	4.76	2,160
<b>UB20K132R9N108</b>	3.54	90	2.48	63	1.10	28	4.25	108	8.58	218	M12	0.51	13	7.43	3,370
<b>UZ20K132R9N108</b>	3.54	90	2.48	63	1.10	28	4.25	108	8.58	218	M12	0.51	13	7.32	3,320

# K2R9

## JIS SSA

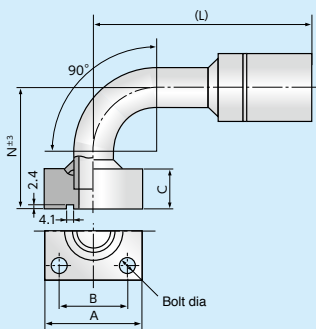

JIS B 2291 20.5MPa Tube Flange

Catalog Number	A $\phi$		B		C		N		(L)		Bolt	Bolt dia		Weight	
	inch	mm	inch	mm	inch	mm	inch	mm	inch	mm		inch	mm	inch	mm
<b>UB08K215R915</b>	2.13	54	1.42	36	0.87	22	2.64	67	4.76	121	M10	0.43	11	1.68	760
<b>UZ08K215R915</b>	2.13	54	1.42	36	0.87	22	2.64	67	4.76	121	M10	0.43	11	1.68	760
<b>UB12K220R969</b>	2.28	58	1.57	40	0.87	22	2.95	75	6.06	154	M10	0.43	11	2.58	1,170
<b>UB16K225R926</b>	2.68	68	1.89	48	1.10	28	3.66	93	6.93	176	M12	0.51	13	3.97	1,800
<b>UB20K232R9N108</b>	2.99	76	2.20	56	1.10	28	4.25	108	8.58	218	M12	0.51	13	6.28	2,850
<b>UZ20K232R9N108</b>	2.99	76	2.20	56	1.10	28	4.25	108	8.58	218	M12	0.51	13	6.17	2,800

Standard product — Material: SS or SC equivalent steel, Surface: Zinc plating or chromate treatment

# Couplings UB / UZ series

**K3R9**

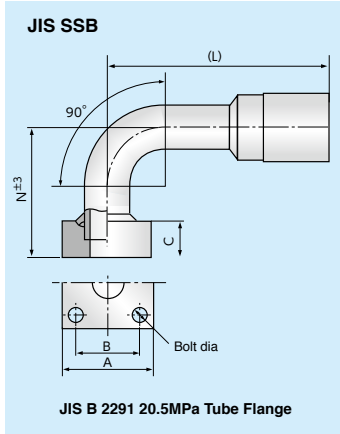

Catalog Number	A $\phi$		B		C		N		(L)		Bolt	Weight	
	inch	mm	inch	mm	inch	mm	inch	mm	inch	mm		lbs	g
UB08K315R9N67	2.13	54	1.42	36	0.87	22	2.64	67	4.76	121	M10	1.68	760
UZ08K315R9N67	2.13	54	1.42	36	0.87	22	2.64	67	4.76	121	M10	1.68	760
UB12K320R9N75	2.28	58	1.57	40	0.87	22	2.95	75	6.06	154	M10	2.49	1,130
UB16K325R9N90	2.68	68	1.89	48	1.10	28	3.54	90	6.93	176	M12	4.06	1,840
UB20K332R9N108	2.99	76	2.20	56	1.10	28	4.25	108	8.58	218	M12	6.28	2,850
UZ20K332R9N108	2.99	76	2.20	56	1.10	28	4.25	108	8.58	218	M12	6.28	2,850

**A1**

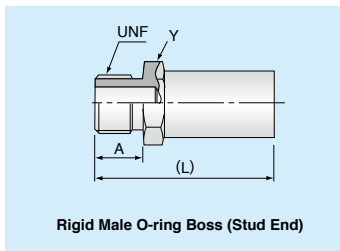

Catalog Number	Y		A		(L)		Weight	
	inch	mm	inch	mm	inch	mm	lbs	g
UZ04A1	0.67	17	3.62	9.2	1.85	47	0.11	50
UZ0406A1	0.75	19	3.90	9.9	1.97	50	0.11	60
UB06A1	0.75	19	3.90	9.9	2.07	53	0.18	80
UB0608A1	0.87	22	4.37	11.1	2.07	53	0.20	90
UB08A1	0.87	22	4.37	11.1	2.17	55	0.24	110
UB0810A1	1.06	27	5.00	12.7	2.32	59	0.31	140
UB10A1	1.06	27	5.00	12.7	2.32	59	0.44	200

**A9**

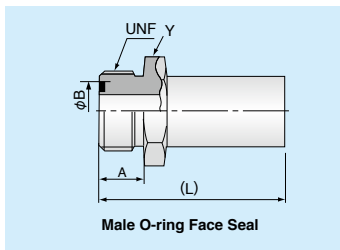

Catalog Number	Y		A		(L)		Weight	
	inch	mm	inch	mm	inch	mm	lbs	g
UZ04A9X604	0.75	19	0.47	12.0	2.09	53	2.56	65
UB06A9X604	0.75	19	0.43	11.0	2.09	53	0.19	85
UB08A9X604	0.87	22	0.51	13.0	2.36	60	0.28	125
UB10A9X604	1.06	27	0.61	15.5	2.91	74	0.46	210
UB12A9X604	1.26	32	0.67	17.0	3.27	83	0.72	325
UB16A9X604	1.61	41	0.69	17.5	3.50	89	1.09	495

Standard product — Material: SS or SC equivalent steel, Surface: Zinc plating or chromate treatment

# Couplings HW / KH / KN / KD / EX series

R

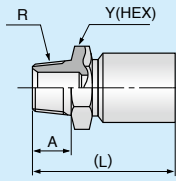

Male British Tapered Pipe Thread (BSPT)

Catalog Number	W Thread	Y		A		(L)		w Weight	
		inch	mm	inch	mm	inch	mm	lbs	g
KH06R	3/8	0.75	19	0.59	15	2.68	68	0.24	110
HW24R	1 1/2	1.97	50	0.98	25	4.69	119	2.14	970
HW32R	2	2.56	65	1.14	29	5.94	151	3.90	1,770

F

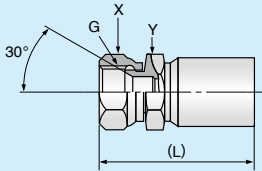

Female Japanese Industrial Pipe Thread (JIS) Female 30° Seat

Catalog Number	W Thread	X		Y		(L)		w Weight	
		inch	mm	inch	mm	inch	mm	lbs	g
HW24F	1 1/2	2.17	55	1.97	50	5.04	128	2.41	1,095
HW32F	2	2.76	70	2.56	65	6.26	159	4.31	1,955

C

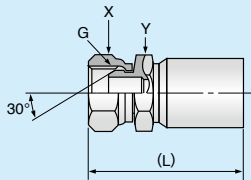

Female British Parallel Pipe Thread Male 30° Seat (BSPOR)

Catalog Number	W Thread	X		Y		(L)		w Weight	
		inch	mm	inch	mm	inch	mm	lbs	g
KH1416C	1	1.61	41	1.42	36	3.82	97	1.09	495
HW24C	1 1/2	2.17	55	1.97	50	5.04	128	2.49	1,130
HW32C	2	2.76	70	2.56	65	6.26	159	4.44	2,015

CR4

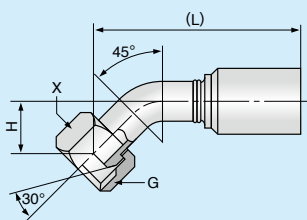

Female British Parallel Pipe Thread Male 30° Seat (BSPOR)

Catalog Number	W Thread	X		H		(L)		w Weight	
		inch	mm	inch	mm	inch	mm	lbs	g
HW24CR4N52	1 1/2	2.17	55	2.05	52	8.74	222	3.59	1,630
HW32CR4N69	2	2.76	70	2.72	69	10.35	263	6.40	2,905

CR9

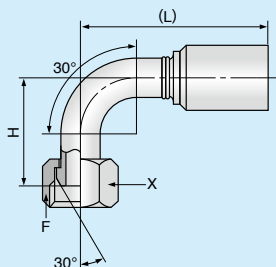

Female British Parallel Pipe Thread Male 30° Seat (BSPOR)

Catalog Number	W Thread	X		H		(L)		w Weight	
		inch	mm	inch	mm	inch	mm	lbs	g
HW24CR9N103	1 1/2	2.17	55	4.06	103	5.63	143	4.19	1,900
HW32CR920	2	2.76	70	5.91	150	8.46	215	7.14	3,240

Q

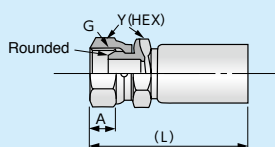

Equipped with safety hole

Catalog Number	W Thread	Y		A		(L)		w Weight	
		inch	mm	inch	mm	inch	mm	lbs	g
KH06QH22	3/8	0.87	22	0.39	10	2.83	72	0.29	130

Standard product — Material: SS or SC equivalent steel, Surface: Zinc plating or chromate treatment

# Couplings HW / KH / KN / KD / EX series

S

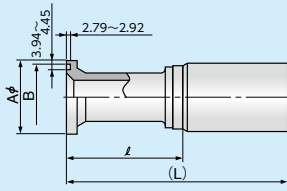

Flange Head S CODE 61 Flange

Catalog Number	Aφ		B		Q		(L)		Weight	
	inch	mm	inch	mm	inch	mm	inch	mm	lbs	g
HW24S	2.36	60	2.13	54	1.73	44	4.65	118	2.04	925
KN24S	2.36	60	2.13	54	3.11	79	7.87	200	4.17	1,890
HW32S	2.80	71	2.48	63	2.01	51	5.91	150	3.57	1,620
KN32S	2.80	71	2.48	63	2.01	51	6.81	173	5.20	2,360

SR4

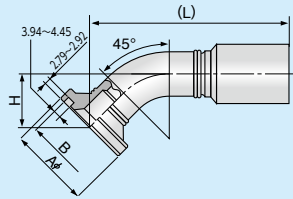

Flange Head S CODE 61 Flange

Catalog Number	Aφ		B		H		(L)		Weight	
	inch	mm	inch	mm	inch	mm	inch	mm	lbs	g
HW24SR4	2.36	60	2.13	54	1.46	37	6.18	157	2.46	1,115
KN24SR4	2.36	60	2.13	54	1.46	37	7.95	202	4.34	1,970
HW32SR4N56	2.80	71	2.48	63	2.21	56	9.37	238	5.10	2,315
KN32SR4N56	2.80	71	2.48	63	2.21	56	10.31	262	6.70	3,040

SR9

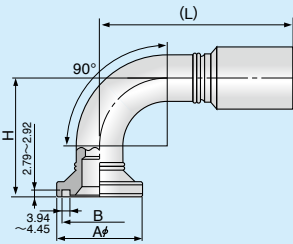

Flange Head S CODE 61 Flange

Catalog Number	Aφ		B		H		(L)		Weight	
	inch	mm	inch	mm	inch	mm	inch	mm	lbs	g
HW24SR9	2.36	60	2.13	54	3.15	80	5.83	148	2.79	1,265
KN24SR9	2.36	60	2.13	54	3.15	80	8.23	209	5.97	2,710
HW2420SR9N67	1.77	45	1.54	39	2.68	68	6.77	172	2.45	1,110
HW32SR9	2.80	71	2.48	63	4.53	115	8.46	215	5.57	2,525
KN32SR9	2.80	71	2.48	63	4.53	115	9.21	234	7.24	3,285

H

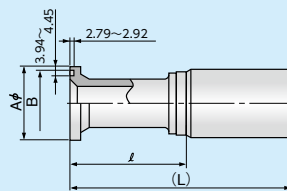

Flange Head H CODE 62 Flange

Catalog Number	Aφ		B		Q		(L)		Weight	
	inch	mm	inch	mm	inch	mm	inch	mm	lbs	g
HW24H	2.52	64	2.13	54	2.17	55	5.08	129	2.36	1,070
KN24H	2.52	64	2.13	54	3.54	90	7.87	200	4.49	2,035
EX32H	3.11	79	2.48	63	3.94	100	8.07	205	7.89	3,580
HW32H	3.11	79	2.48	63	2.72	69	6.65	169	4.30	1,950
KD32H	3.11	79	2.48	63	2.72	69	7.36	187	6.11	2,770
KN32H	3.11	79	2.48	63	2.72	69	7.52	191	5.95	2,700

HR4

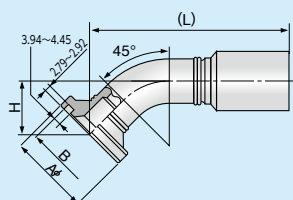

Flange Head S CODE 62 Flange

Catalog Number	Aφ		X		H		(L)		Weight	
	inch	mm	inch	mm	inch	mm	inch	mm	lbs	g
HW24HR4	2.52	64	2.13	54	1.81	46	6.22	158	2.76	1,250
KN24HR4	2.52	64	2.13	54	1.81	46	8.31	211	4.72	2,140
KN24HR4N80	2.52	64	2.13	54	3.15	80	9.21	234	5.21	2,365
HW32HR4N67	3.11	79	2.48	63	2.64	67	9.80	249	5.76	2,615
KD32HR4N69	3.11	79	2.48	63	2.76	70	10.67	271	7.66	3,475
EX32HR4N106	3.11	79	2.48	63	4.21	107	13.74	349	11.32	5,135

Standard product — Material: SS or SC equivalent steel, Surface: Zinc plating or chromate treatment

**HR9**

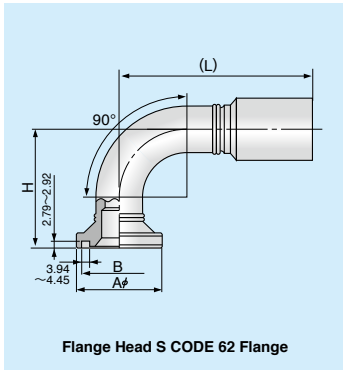

Catalog Number	Aφ		B		H		(L)		Weight	
	inch	mm	inch	mm	inch	mm	inch	mm	lbs	g
<b>KN24HR9</b>	2.52	64	2.13	54	4.72	120	7.80	198	5.49	2,490
<b>HW24HR9N91</b>	2.52	64	2.13	54	3.58	91	5.83	148	3.11	1,410
<b>HW32HR9</b>	3.11	79	2.48	63	5.35	136	8.78	223	6.45	2,925
<b>EX32HR9N155</b>	3.11	79	2.48	63	6.10	155	11.38	289	11.63	5,275
<b>KD32HR903</b>	3.11	79	2.48	63	5.35	136	9.21	234	8.16	3,700

**G**

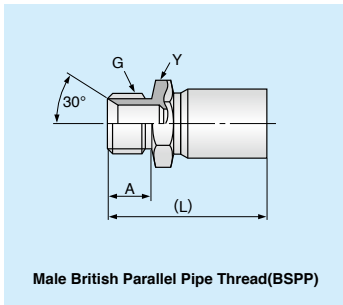

Catalog Number	Thread	Y		A		(L)		Weight	
		inch	mm	inch	mm	inch	mm	lbs	g
<b>KH1416G</b>	1	1.42	36	1.26	32	3.58	91	0.88	400
<b>HW24G</b>	1 1/2	1.97	50	0.98	25	4.69	119	2.11	955
<b>HW32G</b>	2	2.56	65	1.14	29	5.94	151	3.73	1,690

**K**

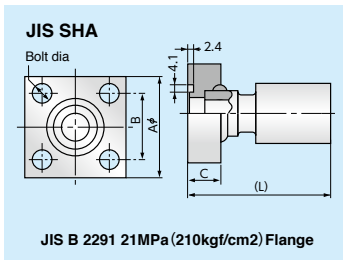

Catalog Number	Aφ		B		C		(L)		Bolt	Bolt dia		Weight	
	inch	mm	inch	mm	inch	mm	inch	mm		inch	mm	lbs	g
<b>HW24K40</b>	3.94	100	2.76	70	1.42	36	5.47	139	M16	0.71	18	8.07	3,660
<b>HW32K50</b>	4.41	112	3.15	80	1.42	36	7.60	193	M16	0.71	18	9.74	4,420
<b>KN32K50</b>	4.41	112	3.15	80	1.42	36	8.27	210	M16	0.71	18	11.62	5,270

**K1**

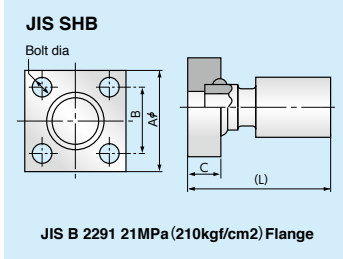

Catalog Number	Aφ		B		C		(L)		Bolt	Bolt dia		Weight	
	inch	mm	inch	mm	inch	mm	inch	mm		inch	mm	lbs	g
<b>HW24K140</b>	3.94	100	2.76	70	1.42	36	5.47	139	M16	0.71	18	6.81	3,090
<b>HW32K150</b>	4.41	112	3.15	80	1.42	36	7.60	193	M16	0.71	18	10.07	4,570
<b>KN32K150</b>	4.41	112	3.15	80	1.42	36	8.27	210	M16	0.71	18	11.53	5,230

Standard product — Material: SS or SC equivalent steel, Surface: Zinc plating or chromate treatment

# Couplings HW / KH / KN / KD / EX series

**K2**

**JIS SSA**

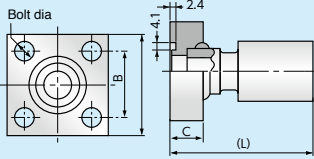

JIS B 2291 21MPa (210kgf/cm<sup>2</sup>) Flange

Catalog Number	A $\phi$		B		C		(L)		Bolt	Bolt dia		Weight	
	inch	mm	inch	mm	inch	mm	inch	mm		inch	mm	lbs	g
<b>HW24K240</b>	3.62	92	2.56	65	1.42	36	5.47	139	M16	0.71	18	7.50	3,400
<b>HW32K250</b>	3.94	100	2.87	73	1.42	36	7.60	193	M16	0.71	18	8.77	3,980
<b>KN32K250</b>	3.94	100	2.87	73	1.42	36	8.27	210	M16	0.71	18	9.99	4,530

**K3**

**JIS SSB**

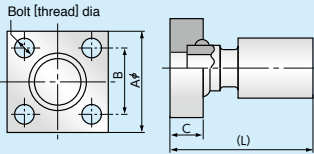

JIS B 2291 21MPa (210kgf/cm<sup>2</sup>) Flange

Catalog Number	A $\phi$		B		C		(L)		Bolt	Weight	
	inch	mm	inch	mm	inch	mm	inch	mm		lbs	g
<b>HW24K340</b>	3.62	92	2.56	65	1.42	36	5.47	139	M16	6.19	2,810
<b>HW32K350</b>	3.94	100	2.87	73	1.42	36	7.60	193	M16	8.75	3,970
<b>KN32K350</b>	3.94	100	2.87	73	1.42	36	8.27	210	M16	10.16	4,610

**K4**

**JIS LSA**

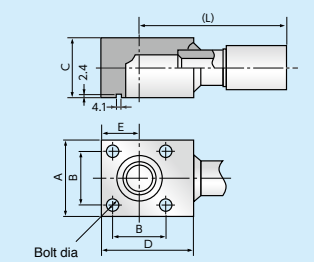

JIS B 2291 20.5MPa Tube Flange

Catalog Number	A $\phi$		B		C		D		E		(L)	Bolt	Bolt dia		Weight		
	inch	mm	inch	mm	inch	mm	inch	mm	inch	mm			inch	mm	inch	mm	lbs
<b>HW24K440</b>	3.62	92	2.56	65	2.80	71	4.33	110	1.81	46	7.52	191	M16	0.71	18	11.40	5,170
<b>HW32K450</b>	3.94	100	2.87	73	3.35	85	4.92	125	1.97	50	9.13	232	M16	0.71	18	17.39	7,890
<b>KN32K450</b>	3.94	100	2.87	73	3.35	85	4.92	125	1.97	50	9.80	249	M16	0.71	18	18.69	8,480

**KR9**

**JIS SHA**

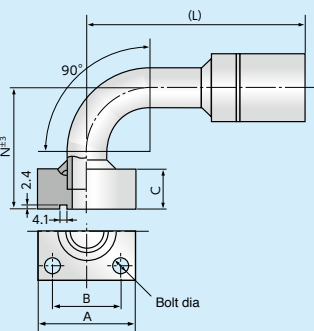

JIS B 2291 20.5MPa Tube Flange

Catalog Number	A $\phi$		B		C		N		(L)		Bolt	Bolt dia		Weight	
	inch	mm	inch	mm	inch	mm	inch	mm	inch	mm		inch	mm	inch	mm
<b>HW24K40R911</b>	3.94	100	2.76	70	1.42	36	5.12	130	7.32	186	M16	0.71	18	8.77	3,980
<b>HW32K50R906</b>	4.41	112	3.15	80	1.42	36	5.94	151	10.35	263	M16	0.71	18	13.67	6,200
<b>KN32K50R907</b>	4.41	112	3.15	80	1.42	36	5.94	151	10.83	275	M16	0.71	18	15.04	6,820

Standard product — Material: SS or SC equivalent steel, Surface: Zinc plating or chromate treatment

**K1R9**

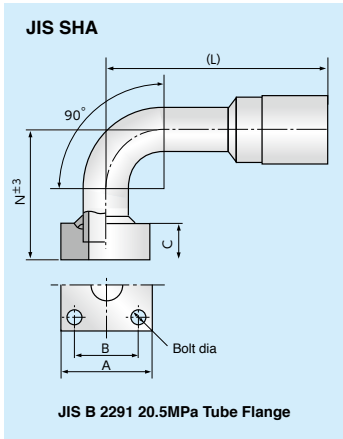

Catalog Number	A $\phi$		B		C		N		(L)		Bolt	Bolt dia		Weight	
	inch	mm	inch	mm	inch	mm	inch	mm	inch	mm		inch	mm	inch	mm
HW24K140R9N130	3.94	100	2.76	70	1.42	36	5.12	130	7.32	186	M16	0.71	18	8.64	3,920
HW32K150R927	4.41	112	3.15	80	1.42	36	5.94	151	10.35	263	M16	0.71	18	13.60	6,170
KN32K150R916	4.41	112	3.15	80	1.42	36	5.94	151	10.83	275	M16	0.71	18	14.97	6,790

**K2R9**

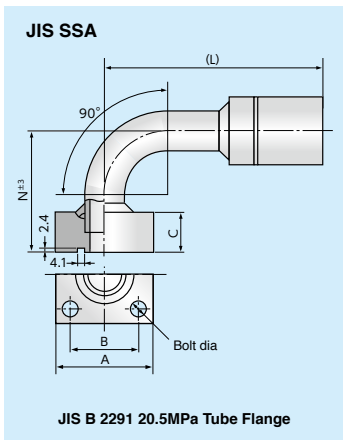

Catalog Number	A $\phi$		B		C		N		(L)		Bolt	Bolt dia		Weight	
	inch	mm	inch	mm	inch	mm	inch	mm	inch	mm		inch	mm	inch	mm
HW24K240R913	3.62	92	2.56	65	1.42	36	5.12	130	7.32	186	M16	0.71	18	7.56	3,430
HW32K250R925	3.94	100	2.87	73	1.42	36	5.94	151	10.35	263	M16	0.71	18	12.06	5,470
KN32K250R913	3.94	100	2.87	73	1.42	36	5.93	150.5	10.79	274	M16	0.71	18	13.43	6,090

**K3R9**

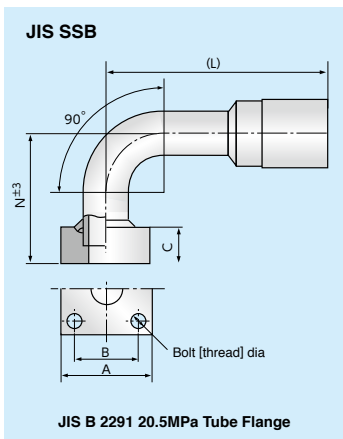

Catalog Number	A $\phi$		B		C		N		(L)		Bolt	Weight	
	inch	mm	inch	mm	inch	mm	inch	mm	inch	mm		lbs	g
HW24K340R9N130	3.62	92	2.56	65	1.42	36	5.12	130	7.32	186	M16	7.87	3,570
HW32K350R9N151	3.94	100	2.87	73	1.42	36	5.94	151	10.35	263	M16	12.79	5,800
KN32K350R9N151	3.94	100	2.87	73	1.42	36	5.94	151	10.83	275	M16	14.18	6,430

**Q2**

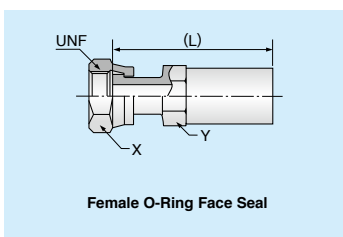

Catalog Number	Thread	X		Y		(L)		Weight	
		inch	mm	inch	mm	inch	mm	lbs	g
HW24Q2	2-12	2.17	55	2.17	55	5.00	127	2.94	1,335
KN24Q2	2-12	2.17	55	2.17	55	6.10	155	4.42	2,005

Standard product — Material: SS or SC equivalent steel, Surface: Zinc plating or chromate treatment

# Couplings HW / KH / KN / KD / EX series

**Q2R9**

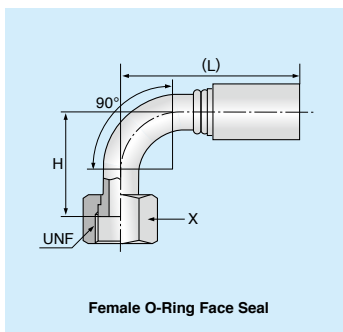

Catalog Number	W Thread	X		H		(L)		Weight	
		inch	mm	inch	mm	inch	mm	lbs	g
HW24Q2R9	2-12	1.97	50	3.58	91	5.51	140	4.02	1,825

**F2**

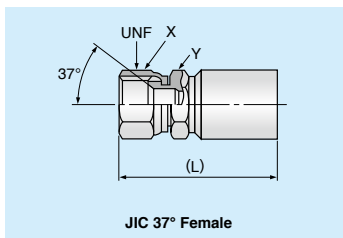

Catalog Number	W Thread	X		Y		(L)		Weight	
		inch	mm	inch	mm	inch	mm	lbs	g
HW24F2	1 5/8-12	2.17	55	2.17	55	5.35	136	2.92	1,325
HW32F2	1 5/8-12	2.95	75	2.95	75	6.65	169	5.75	2,610

Standard product — Material: SS or SC equivalent steel, Surface: Zinc plating or chromate treatment



# Couplings EA / EC / EK / GA / GB / UF / UG / ZP series

R

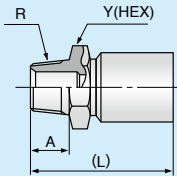

Male British Tapered Pipe Thread (BSPT)

Catalog Number	Thread	Y		A		(L)		Weight	
		inch	mm	inch	mm	inch	mm	lbs	g
EA0304R	1/4	0.75	19	0.51	13	1.89	48	0.10	45
EC0304R	1/4	0.75	19	0.51	13	1.93	49	0.11	50
EK04R	1/4	0.75	19	0.51	13	2.87	73	0.23	105
GA04R	1/4	0.67	17	0.51	13	1.97	50	0.10	45
GB04R	1/4	0.67	17	0.51	13	1.97	50	0.11	50
ZP0406R	3/8	0.75	19	0.47	12	2.36	60	0.19	85
ZP0406RH22	3/8	0.87	22	0.47	12	2.40	61	0.19	85
EK06R	3/8	0.87	22	0.59	15	3.11	79	0.31	140
GA06R	3/8	0.75	19	0.59	15	2.28	58	0.17	75
UF06R	3/8	0.75	19	0.59	15	2.24	57	0.20	90
UG06R	3/8	0.75	19	0.59	15	2.28	58	0.21	95
EK08R	1/2	1.06	27	0.71	18	3.54	90	0.49	220
UF08R	1/2	0.87	22	0.71	18	2.52	64	0.29	130
UG08R	1/2	0.87	22	0.71	18	2.64	67	0.28	125
GB12R	3/4	1.18	30	0.79	20	3.35	85	0.62	280
UG12R	3/4	1.18	30	0.79	20	2.99	76	0.56	255
GB16R	1	1.42	36	0.87	22	3.66	93	0.95	430
UG16R	1	1.42	36	0.87	22	3.39	86	0.87	395
EC24R	1 1/2	1.97	50	0.98	25	4.69	119	1.98	900
EC32R	2	2.56	65	1.14	29	5.94	151	3.51	1,590

F

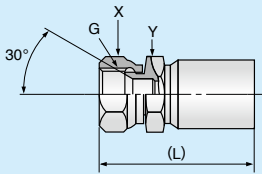

Female Japanese Industrial Pipe Thread (JIS) Female 30° Seat

Catalog Number	Thread	X		Y		(L)		Weight	
		inch	mm	inch	mm	inch	mm	lbs	g
EA0304F	1/4	0.75	19	0.75	19	2.09	53	0.13	60
EC0304F	1/4	0.75	19	0.75	19	2.13	54	0.15	70
GA04F	1/4	0.75	19	0.67	17	2.20	56	0.14	65
GB04F	1/4	0.75	19	0.67	17	2.20	56	0.14	65
GA06F	3/8	0.87	22	0.75	19	2.44	62	0.20	90
UF06F	3/8	0.87	22	0.75	19	2.40	61	0.23	105
UG06F	3/8	0.87	22	0.75	19	2.52	64	0.24	110
UF08F	1/2	1.06	27	0.87	22	2.64	67	0.33	150
UG08F	1/2	1.06	27	0.87	22	2.76	70	0.33	150
GB12F	3/4	1.42	36	1.18	30	3.58	91	0.78	355
UG12F	3/4	1.42	36	1.18	30	3.19	81	0.73	330
GB16F	1	1.61	41	1.42	36	3.90	99	1.14	515
UG16F	1	1.61	41	1.42	36	3.62	92	1.06	480
EC24F	1 1/2	2.17	55	1.97	50	5.04	128	2.23	1,010
EC32F	2	2.76	70	2.56	65	6.26	159	4.02	1,825

Q

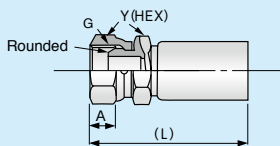

Equipped with safety hole

Catalog Number	Thread	Y		A		(L)		Weight	
		inch	mm	inch	mm	inch	mm	lbs	g
ZP04Q	1/4	0.75	19	0.39	10	2.52	64	0.19	85
EK04Q	1/4	0.75	19	0.39	10	3.11	79	0.27	123
EK06Q	3/8	0.87	22	0.39	10	3.11	79	0.32	146
EK08Q	1/2	1.06	27	0.43	11	3.43	87	0.50	227

Standard product — Material: SS or SC equivalent steel, Surface: Zinc plating or chromate treatment

# Couplings EA / EC / EK / GA / GB / UF / UG / ZP series

**C**

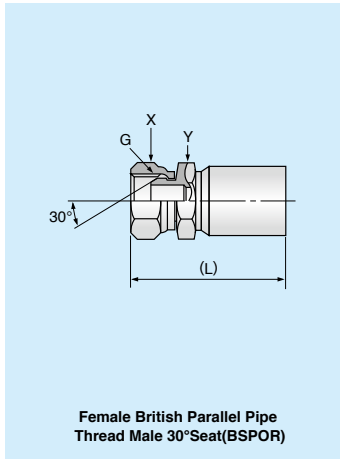

Catalog Number	W Thread	X		Y		(L)		Weight	
		inch	mm	inch	mm	inch	mm	lbs	g
EA0304C	1/4	0.75	19	0.75	19	2.09	53	0.13	60
EC0304C	1/4	0.75	19	0.75	19	2.13	54	0.15	70
GA04C	1/4	0.75	19	0.67	17	2.20	56	0.14	65
GB04C	1/4	0.75	19	0.67	17	2.20	56	0.14	65
GA06C	3/8	0.87	22	0.75	19	2.44	62	0.20	90
UF06C	3/8	0.87	22	0.75	19	2.44	62	0.23	105
UG06C	3/8	0.87	22	0.75	19	2.44	62	0.24	110
UF08C	1/2	1.06	27	0.87	22	2.64	67	0.34	155
UG08C	1/2	1.06	27	0.87	22	2.76	70	0.33	150
GB12C	3/4	1.42	36	1.18	30	3.54	90	0.79	360
UG12C	3/4	1.42	36	1.18	30	3.19	81	0.74	335
GB16C	1	1.61	41	1.42	36	3.66	93	1.15	520
UG16C	1	1.61	41	1.42	36	3.62	92	1.07	485
EC24C	1 1/2	2.17	55	1.97	50	5.04	128	2.28	1,035
EC32C	2	2.76	70	2.56	65	6.26	159	4.08	1,850

**CR4**

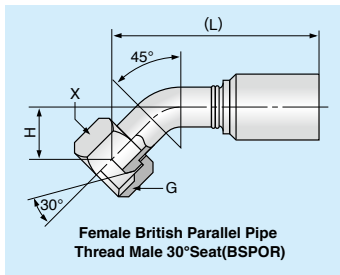

Catalog Number	W Thread	X		H		(L)		Weight	
		inch	mm	inch	mm	inch	mm	lbs	g
GA04CR4	1/4	0.75	19	0.94	24	3.03	77	0.17	75
GB04CR4	1/4	0.75	19	0.94	24	3.03	77	0.17	75

**CR9**

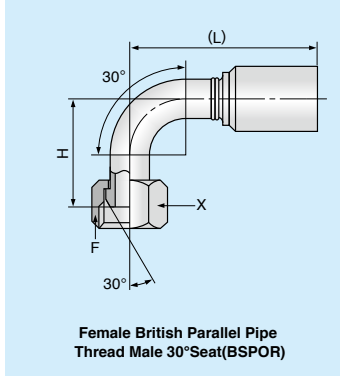

Catalog Number	W Thread	X		H		(L)		Weight	
		inch	mm	inch	mm	inch	mm	lbs	g
GA04CR9	1/4	0.75	19	0.94	24	2.36	60	0.15	70
GB04CR9	1/4	0.75	19	0.94	24	2.36	60	0.15	70
GA06CR9	3/8	0.87	22	1.50	38	2.64	67	0.25	115
UF06CR9	3/8	0.87	22	1.50	38	2.64	67	0.29	130
UG06CR9	3/8	0.87	22	1.50	38	2.76	70	0.30	135
UF08CR9	1/2	1.06	27	1.81	46	3.39	86	0.46	210
UG08CR9	1/2	1.06	27	1.81	46	3.50	89	0.45	205
GB12CR9	3/4	1.42	36	2.36	60	4.02	102	0.97	440
UG12CR9	3/4	1.42	36	2.36	60	3.66	93	0.91	415
UG16CR9	1	1.61	41	2.76	70	4.65	118	1.49	675
EC24CR9	1 1/2	2.17	55	4.13	105	7.24	184	3.13	1,420
EC32CR9	2	2.76	70	5.91	150	8.46	215	7.10	3,220

Standard product — Material: SS or SC equivalent steel, Surface: Zinc plating or chromate treatment

**S**

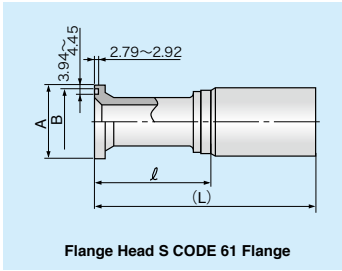

Flange Head S CODE 61 Flange

Catalog Number	A $\phi$		B		$\phi$		(L)		Weight	
	inch	mm	inch	mm	inch	mm	inch	mm	lbs	g
GB12S	1.50	38.10	1.255~1.250	31.88~31.75	1.38	35	3.54	90	0.66	300
GB16S	1.75	44.45	1.565~1.560	39.75~39.62	1.38	35	3.66	93	0.96	435
EC24S	2.37	60.32	2.125~2.115	53.98~53.72	1.73	44	4.69	119	1.74	790
EC32S	2.81	71.42	2.500~2.490	63.50~63.25	1.97	50	5.91	150	3.59	1,630

**SR9**

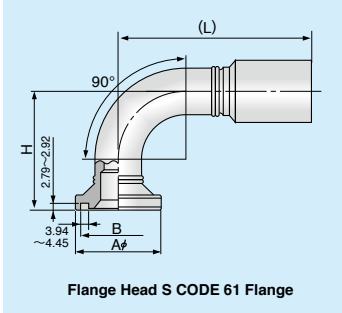

Flange Head S CODE 61 Flange

Catalog Number	A $\phi$		B		H		(L)		Weight	
	inch	mm	inch	mm	inch	mm	inch	mm	lbs	g
GB12SR9	1.50	38.10	1.255~1.250	31.88~31.75	2.13	54	3.94	100	0.85	385
GB16SR9	1.75	44.45	1.565~1.560	39.75~39.62	2.36	60	4.45	113	1.27	575

**H**

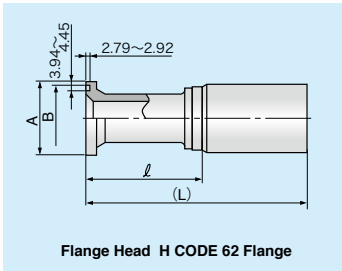

Flange Head H CODE 62 Flange

Catalog Number	A $\phi$		B		$\phi$		(L)		Weight	
	inch	mm	inch	mm	inch	mm	inch	mm	lbs	g
GB12H	1.62	41.28	1.255~1.250	31.88~31.75	1.38	35	3.54	90	0.69	315
GB16H	1.87	47.63	1.565~1.560	39.75~39.62	1.50	38	3.82	97	1.06	480

**HR9**

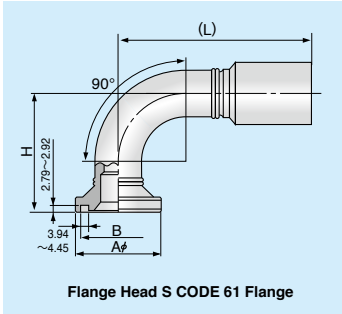

Flange Head S CODE 61 Flange

Catalog Number	A $\phi$		B		H		(L)		Weight	
	inch	mm	inch	mm	inch	mm	inch	mm	lbs	g
GB12HR9	1.62	41.28	1.255~1.250	31.88~31.75	2.28	58	3.98	101	0.90	410
GB16HR9	1.87	47.63	1.565~1.560	39.75~39.62	2.87	73	4.45	113	1.41	640

**G**

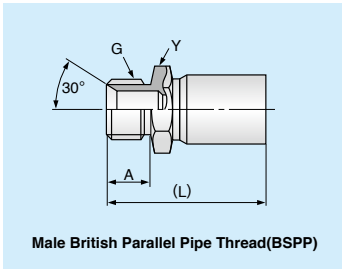

Male British Parallel Pipe Thread (BSPP)

Catalog Number	Thread	Y		A		(L)		Weight	
		inch	mm	inch	mm	inch	mm	lbs	g
GA04G	1/4	0.67	17	0.51	13	1.97	50	0.10	45
GB04G	1/4	0.67	17	0.51	13	1.97	50	0.11	50
GA06G	3/8	0.75	19	0.59	15	2.28	58	0.15	70
UF06G	3/8	0.75	19	0.59	15	2.24	57	0.20	90
UF08G	1/2	0.87	22	0.71	18	2.52	64	0.28	125
GB12G	3/4	1.18	30	0.79	20	2.99	76	0.61	275
UG12G	3/4	1.18	30	0.79	20	2.99	76	0.55	250
GB16G	1	1.42	36	0.87	22	3.66	93	0.95	430

Standard product — Material: SS or SC equivalent steel, Surface: Zinc plating or chromate treatment

# PASSTAGE LINE series

## PASSTAGE LINE

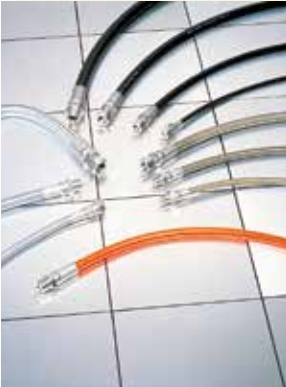

### 1 Small bending radius

Passtage series hose has 30% smaller minimum bending radius than equivalent rubber hose

### 2 Lightweight

Passtage series has 50% lighter weight than equivalent rubber hose.

### 3 Application-specific hoses available

The AG10 series for machine tools, the PS/PC series for paint sprays, and the WSH series for cleaning machines are available.

### 4 SELFIT series available for SPL and KF only

The SELFIT series, now patented in eight countries including Japan, is a line of push-type coupling systems for high-pressure hoses. They do not require a crimping machine. For details, refer to pages 54 to 58 and the "SELFIT" catalog.

#### Flexible architecture

#### KF·KG

- Compatible Fluid  
Mineral Oil
- Inner Tube  
Polyester
- Outer Cover  
Polyurethane
- Temperature Range: fluid  
-40°C to 100°C/  
-40°F to 212°F
- Temperature Range: ambient  
-40°C to 70°C/  
-40°F to 158°F

Catalog Number	I.D.		O.D.		Max.W.P.		Min.B.P.		Min.B.R.		Weight		Reinforcement	Compatible coupling/relevant page	
	inch	mm	inch	mm	psi	MPa	psi	MPa	inch	mm	lbs/ft	g/m		Factory-assembled	UNICRIMP-crimped
<b>KF04</b>	1/4	6.3	0.49	12.4	3,000	20.5	12,000	82.0	1.38	35	0.07	110	1P	JY/50	SY/50
<b>KF06</b>	3/8	9.5	0.65	16.6	2,500	17.0	10,000	68.0	1.77	45	0.11	160		SY/50	UX/30
<b>KF12</b>	1/2	12.7	0.81	20.6	2,000	14.0	8,000	56.0	2.56	65	0.17	250		SY/50	UX/30
<b>KG06</b>	3/8	9.5	0.68	17.2	3,000	20.5	12,000	82.0	2.17	55	0.13	190	2P	SY/50	SY/50
<b>KG08</b>	1/2	12.7	0.84	21.4	3,000	20.5	12,000	82.0	2.56	65	0.17	260		SY/50	SY/50

**Warning** If you use a SELFIT FR series coupling with the KF06 hose, the maximum working pressure is 16.0MPa. For details, refer to page 51. Pressurizing the KF06 hose to a working pressure exceeding the maximum could cause it to burst or blow the couplings off. ( In case SELFIT is used) Severe personal injury or death may result if these instructions are not followed.

#### Small Bending radius

#### SPL

- Compatible Fluid  
Mineral Oil
- Inner Tube  
Polyester
- Outer Cover  
Polyurethane
- Temperature Range: fluid  
-40°C to 100°C/-40°F to 212°F
- Temperature Range: ambient  
-40°C to 70°C/-40°F to 158°F

Catalog Number	I.D.		O.D.		Max.W.P.		Min.B.P.		Min.B.R.		Weight		Reinforcement	Compatible coupling/relevant page	
	inch	mm	inch	mm	psi	MPa	psi	MPa	inch	mm	lbs/ft	g/m		Factory-assembled	UNICRIMP-crimped
<b>SPL03</b>	3/16	4.8	0.36	9.2	2,000	14.0	8,000	56.0	0.79	20	0.03	50	1P	CG/50	SG/50
<b>SPL04</b>	1/4	6.3	0.42	10.6					1.38	35	0.04	60	2C	JG/50	
<b>SPL06</b>	3/8	9.5	0.60	15.2	2.17	55	0.08	120	1P	SG/50					
<b>SPL08</b>	1/2	12.7	0.75	19.0	1,500	10.5	6,000	42.0	2.76	70	0.11	170	1P	SG/50	SG/50

**Warning** One end of an SPL hose can be equipped with a crimped coupling and the other end with a SELFIT coupling. If an SPL hose is equipped with one of the SELFIT FS/FU series couplings, its maximum working pressure will be 10.5MPa, which is different from the pressure specified above. For details, refer to page 54. Pressurizing the SPL hose to a working pressure exceeding the maximum could cause it to burst or blow the couplings off. ( In case SELFIT is used) Severe personal injury or death may result if these instructions are not followed.

#### KA/KB

- Compatible Fluid  
Mineral Oil
- Inner Tube  
Nylon 12
- Outer Cover  
Polyurethane
- Temperature Range: fluid  
-40°C to 100°C/  
-40°F to 212°F
- Temperature Range: ambient  
-40°C to 70°C/  
-40°F to 158°F

Catalog Number	I.D.		O.D.		Max.W.P.		Min.B.P.		Min.B.R.		Weight		Reinforcement	Compatible coupling/relevant page	
	inch	mm	inch	mm	psi	MPa	psi	MPa	inch	mm	lbs/ft	g/m		Factory-assembled	UNICRIMP-crimped
<b>KA02</b>	1/8	3.2	0.31	7.9	2,800	19.5	11,200	78.0	0.47	12	0.03	50	1P	SY/50	SY/50
<b>KA03</b>	3/16	4.8	0.38	9.6	2,200	15.0	9,000	61.5	1.38	35	0.05	70		CY/50	CY/50
<b>KA04</b>	1/4	6.3	0.46	11.7	2,100	14.5	8,400	58.0	1.77	45	0.06	90		JY/50	SY(UL)/50(30)
<b>KA05</b>	5/16	7.9	0.54	13.7	1,700	12.0	6,800	48.0	2.36	60	0.07	110	1P	SY/50	SY(UL)/50
<b>KA06</b>	3/8	9.5	0.61	15.6	1,500	10.5	6,000	42.0	2.76	70	0.09	140		SY/50	UX/30
<b>KA08</b>	1/2	12.7	0.77	19.6	1,500	10.5	6,000	42.0	4.13	105	0.13	190		SY/50	UX/30
<b>KA12</b>	3/4	19.0	1.04	26.3	700	5.0	3,000	20.5	9.06	230	0.19	280	2P	CY/50	CY/50
<b>KB03</b>	3/16	4.8	0.43	10.8	3,700	25.5	15,000	103.0	1.38	35	0.06	90		JY/50	SY(UL)/50(30)
<b>KB04</b>	1/4	6.3	0.51	12.9	3,200	22.0	12,800	88.0	1.77	45	0.08	120		SY/50	UX/30
<b>KB05</b>	5/16	7.9	0.59	14.9	3,000	20.5	12,000	82.0	2.36	60	0.09	140	2P	SY/50	SY(UL)/50(30)
<b>KB06</b>	3/8	9.5	0.67	16.9	2,500	17.0	10,000	68.0	2.76	70	0.11	170		SY/50	UX/30
<b>KB08</b>	1/2	12.7	0.83	21.0	2,300	16.0	9,500	65.5	4.13	105	0.15	230		SY/50	UX/30
<b>KB12</b>	3/4	19.0	1.09	27.8	1,400	9.5	5,600	38.0	9.06	230	0.23	340	1P	SY/50	UX/30
<b>KB16</b>	1	25.4	1.41	35.7	1,100	7.5	4,400	30.0	11.42	290	0.35	520		SY/50	UX/30

■KB03 to KB12 are equivalent to ISO 3949 type R7 and SAE 100R7 hoses.  
■KG06 and KG08 are equivalent to SAE 100R18 hoses.

#### Reinforcing

1P

1 polyester braid

2C

2 textile spiral

2P

2 polyester braids

# Special Application Resin Hoses

## Resin Hoses For Machine Tools

- Compatible Fluid / Mineral Hydraulic Oil
- Inner Tube / Polyurethane
- Outer cover / Soft steel wire 1 braid

- Temperature Range: fluid / -40°C to 93°C / -40°F to 199.4°F
- Recommended Temperature Range: ambient / -40°C to 70°C / -40°F to 158°F

### AG10

Catalog Number	I.D.		O.D.		Max.W.P.		Min.B.P.		Min.B.R.		Weight		Reinforcement	Compatible coupling/relevant page	
	inch	mm	inch	mm	psi	MPa	psi	MPa	inch	mm	lbs/ft	g/m		Factory-assembled	UNICRIMP-cripped
AG1004	1/4	6.3	0.46	11.8	1,500	10.5	6,000	42.0	1.38	35	0.11	160	1P	JG/50	SG/50
AG1006	3/8	9.5	0.62	15.7					2.17	55	0.15	230		SG/50	
AG1008	1/2	12.7	0.78	19.8					2.76	70	0.24	350			

## PS For Paint Spray

- Compatible Fluid / Organic Solvent
- Inner Tube / Nylon 12
- Outer Cover / Polyurethane(PC), Soft Vinyl Chloride(PS)

- Temperature Range: fluid / -20°C to 80°C / -4°F to 176°F
- Temperature Range : ambient / -20°C to 40°C / -4°F to 104°F

### PS

Catalog Number	I.D.		O.D.		Max.W.P.		Min.B.P.		Min.B.R.		Weight		Reinforcement	Compatible coupling/relevant page	
	inch	mm	inch	mm	psi	MPa	psi	MPa	inch	mm	lbs/ft	g/m		Factory-assembled	UNICRIMP-cripped
PS03	3/16	4.8	0.39	10.0	4,500	31.0	13,500	93.0	1.38	35	0.08	120	1W (Stainless)	CY/50	
PS04	1/4	6.3	0.47	12.0	4,000	27.5	12,000	82.5	1.77	45	0.11	160		JY/50	
PS05	5/16	7.9	0.57	14.6	3,600	24.5	10,800	73.5	2.36	60	0.13	200		SY/50	

## WSH For Cleaning

- Compatible Fluid / Water
- Inner Tube / Special resin
- Outer cover / Polyurethane (red)

- Temperature Range: fluid / -40°C to 93°C / -40°F to 199.4°F
- Recommended Temperature Range: ambient / -40°C to 70°C / -40°F to 158°F

### WSH

Catalog Number	I.D.		O.D.		Max.W.P.		Min.B.P.		Min.B.R.		Weight		Reinforcement	Compatible coupling/relevant page	
	inch	mm	inch	mm	psi	MPa	psi	MPa	inch	mm	lbs/ft	g/m		Factory-assembled	UNICRIMP-cripped
WSH04	1/4	6.3	0.50	12.8	2,000	14.0	6,000	42.0	1.38	35	0.07	100	1P	JY/50	SY/50
WSH06	3/8	9.5	0.69	17.4					2.17	55	0.11	170		UY/50	UY/50

## JC 70 For Hydraulic Jack

- Compatible Fluid / Mineral Oil
- Inner Tube / Nylon 12
- Outer Cover / Polyurethane(Color:Orange)

- Temperature Range: fluid / -40°C to 70°C / -40°F to 158°F
- Temperature Range : ambient / -40°C to 70°C / -40°F to 158°F

### JC70

Catalog Number	I.D.		O.D.		Max.W.P.		Min.B.P.		Min.B.R.		Weight		Reinforcement	Compatible coupling/relevant page	
	inch	mm	inch	mm	psi	MPa	psi	MPa	inch	mm	lbs/ft	g/m		Factory-assembled	UNICRIMP-cripped
JC7003	3/16	4.8	0.52	13.1	9,900	68.6	20,000	137.2	2.76	70	0.09	130	3P	CW/50	

- Hoses for hydraulic jacks also include the PrimoLine series hoses, which are available in different sizes than those specified above. (Pages 59 to 63)
- JC7003 has excellent electrical insulation properties.

## SF For Steam

- Compatible Fluid / Mineral Oil
- Inner Tube / Nylon 12
- Outer Cover / Polyurethane(Color:Orange)

- Temperature Range: fluid / -40°C to 70°C / -40°F to 158°F
- Temperature Range : ambient / -40°C to 70°C / -40°F to 158°F

### SF

#### 2.0MPa

Catalog Number	I.D.		O.D.		Max.W.P.		Min.B.P.		Min.B.R.		Weight		Reinforcement	Compatible coupling/relevant page		
	inch	mm	inch	mm	psi	MPa	psi	MPa	inch	mm	lbs/ft	g/m		Factory-assembled	UNICRIMP-cripped	
SF04	1/4	6.3	0.39	9.9	300	2.0	8,000	56.0	2.56	65	0.07	110	1W (Stainless)	JG/50	SG/50	
SF06	3/8	9.5	0.54	13.6			6,000	42.0	3.94	100	0.11	170		SG/50		
SF08	1/2	12.7	0.65	16.4			5.32	135	0.14	210					SH/50	
SF10	5/8	15.9	0.79	20.1			4,000	28.0	6.69	170	0.19	280				

- \*SF hoses can handle steam as well as fluid. When using them for liquid, contact us for information about the temperature range and working pressure.

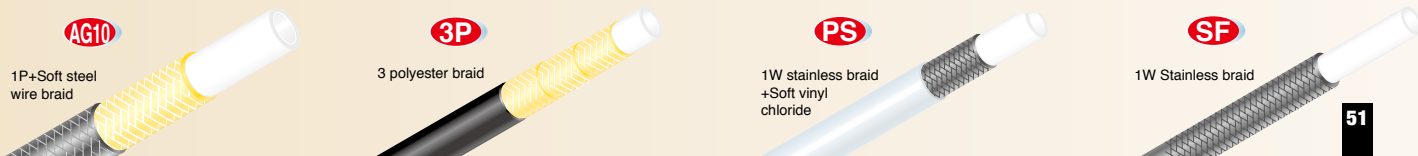

# Couplings CY / CW / JG / JY / SG / SH / SY / UY series

**R**

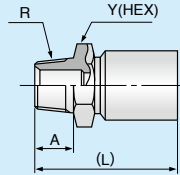

Male British Tapered Pipe Thread(BSPT)

Catalog Number	W Thread	Y		A		(L)		Weight	
		inch	mm	inch	mm	inch	mm	lbs	g
SY02R	1/8	0.55	14	0.39	10	1.46	37	0.03	15
CY0304R	1/4	0.75	17	0.51	13	1.77	45	0.09	40
CW0306R	3/8	0.87	22	0.59	15	2.36	60	0.11	50
JG04R	1/4	0.67	17	0.51	13	1.85	47	0.08	35
JY04R	1/4	0.67	17	0.51	13	1.89	48	0.10	45
SG04R	1/4	0.67	17	0.51	13	1.85	47	0.09	40
SY04R	1/4	0.67	17	0.51	13	1.89	48	0.10	45
SY0506R	3/8	0.75	19	0.59	15	2.52	64	0.14	65
SG06R	3/8	0.75	19	0.59	15	2.40	61	0.15	70
SY06R	3/8	0.75	19	0.59	15	2.52	64	0.19	85
UY06R	3/8	0.75	19	0.59	15	2.52	64	0.19	85
SG08R	1/2	0.87	22	0.71	18	2.87	73	0.25	115
SH08R	1/2	0.87	22	0.71	18	2.87	73	0.26	120
SY08R	1/2	0.87	22	0.71	18	2.87	73	0.31	140
SH1012R	3/4	1.26	32	0.79	20	2.83	72	0.36	165
SY12R	3/4	1.18	30	0.79	20	2.91	74	0.51	230
SH1416R	1	1.42	36	0.87	22	2.91	74	0.47	215
SY16R	1	1.42	36	0.87	22	3.50	89	0.82	370

**F**

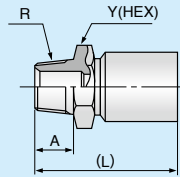

Male British Tapered Pipe Thread(BSPT)

Catalog Number	W Thread	X		Y		(L)		Weight	
		inch	mm	inch	mm	inch	mm	lbs	g
SY02F	1/8	0.55	14	0.55	14	1.69	43	0.06	25
CG0304F	1/4	0.75	19	0.75	17	2.09	53	0.10	45
CY0304F	1/4	0.75	19	0.75	17	1.97	50	0.11	50
JG04F	1/4	0.75	19	0.75	17	2.09	53	0.12	55
JY04F	1/4	0.75	19	0.75	17	2.13	54	0.13	60
SG04F	1/4	0.75	19	0.75	17	2.09	53	0.12	55
SY04F	1/4	0.75	19	0.75	17	2.13	54	0.13	60
SY0506F	3/8	0.87	22	0.87	17	2.36	60	0.17	75
SG06F	3/8	0.87	22	0.87	19	2.56	65	0.19	85
SY06F	3/8	0.87	22	0.87	19	2.68	68	0.22	100
UY06F	3/8	0.87	22	0.75	19	2.68	68	0.22	100
SG08F	1/2	1.06	27	1.06	22	2.87	73	0.30	135
SH08F	1/2	1.06	27	1.06	22	2.87	73	0.31	140
SY08F	1/2	1.06	27	1.06	22	2.99	76	0.35	160
SH1012F	3/4	1.42	36	1.42	32	3.03	77	0.53	240
SY12F	3/4	1.42	36	1.42	30	3.11	79	0.63	285
SH1416F	1	1.61	41	1.61	36	3.15	80	0.64	290
SY16F	1	1.61	41	1.61	36	3.74	95	0.99	450

Standard product — Material: SS or SC equivalent steel, Surface: Zinc plating or chromate treatment

**C**

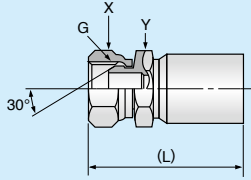

Female British Parallel Pipe Thread Male 30° Seat (BSPOR)

Catalog Number	W Thread	X		Y		(L)		w Weight	
		inch	mm	inch	mm	inch	mm	lbs	g
SY02C	1/8	0.55	14	0.55	14	1.65	42	0.06	25
CG0304C	1/4	0.75	19	0.75	17	1.97	50	0.10	45
CY0304CH17	1/4	0.75	19	0.67	17	2.09	53	0.11	50
SG0304C	1/4	0.75	19	0.67	17	1.97	50	0.11	50
JG04C	1/4	0.75	19	0.67	17	2.09	53	0.12	55
JY04C	1/4	0.75	19	0.67	17	2.13	54	0.13	60
SG04C	1/4	0.75	19	0.67	17	2.05	52	0.12	55
SY04C	1/4	0.75	19	0.67	17	2.13	54	0.13	60
SY0506C	3/8	0.87	22	0.67	17	2.32	59	0.17	75
SG06C	3/8	0.87	22	0.75	19	2.56	65	0.20	90
SY06C	3/8	0.87	22	0.75	19	2.68	68	0.22	100
UY06C	3/8	0.87	22	0.75	19	2.68	68	0.22	100
SG08C	1/2	1.06	27	0.87	22	2.87	73	0.31	140
SH08C	1/2	1.06	27	0.87	22	2.87	73	0.32	145
SY08C	1/2	1.06	27	0.87	22	2.99	76	0.36	165
SY12C	3/4	1.42	36	1.18	30	3.23	82	0.65	295
SY16C	1	1.42	41	1.42	36	3.74	95	0.97	440

**CR4**

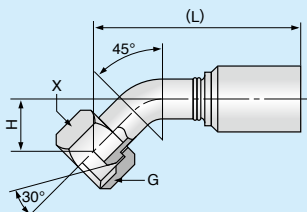

Female British Parallel Pipe Thread Male 30° Seat (BSPOR)

Catalog Number	W Thread	X		H		(L)		w Weight	
		inch	mm	inch	mm	inch	mm	lbs	g
CG0304CR4	1/4	0.75	19	0.94	24	2.72	69	0.12	55
JG04CR4	1/4	0.75	19	0.94	24	2.87	73	0.14	65
JY04CR4	1/4	0.75	19	0.94	24	2.60	66	0.15	70
SY04CR4	1/4	0.75	19	0.94	24	2.60	66	0.15	70
SG06CR4	3/8	0.87	22	1.02	26	4.29	109	0.25	115
SY06CR4	3/8	0.87	22	1.02	26	3.66	93	0.29	130
SY08CR4C6	1/2	1.06	27	0.87	22	5.16	131	0.51	230

**CR9**

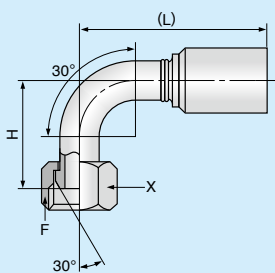

Female British Parallel Pipe Thread Male 30° Seat (BSPOR)

Catalog Number	W Thread	X		H		(L)		w Weight	
		inch	mm	inch	mm	inch	mm	lbs	g
CG0304CR9	1/4	0.75	19	0.94	24	2.05	52	0.11	50
JG04CR9	1/4	0.75	19	0.94	24	2.20	56	0.13	60
JY04CR9	1/4	0.75	19	0.94	24	2.28	58	0.14	65
SG04CR9	1/4	0.75	19	0.94	24	2.20	56	0.13	60
SY04CR9	1/4	0.75	19	0.94	24	2.28	58	0.14	65
SG06CR9	3/8	0.87	22	1.50	38	2.76	70	0.25	115
SY06CR9	3/8	0.87	22	1.50	38	2.87	73	0.29	130
SY08CR9C6	1/2	1.06	27	1.81	46	4.13	105	0.51	230
SG08CR9N46CJ	1/2	1.06	27	1.81	46	4.13	105	0.44	200

**C1**

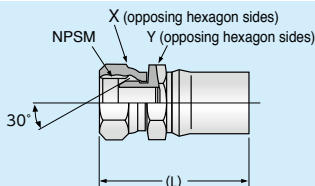

Male American Parallel Pipe Thread Male 30° Seat

Catalog Number	W Thread	X		Y		(L)		w Weight	
		inch	mm	inch	mm	inch	mm	lbs	g
CY0304C1	1/4	0.75	19	0.75	17	2.01	51	0.11	50
JY04C1	1/4	0.75	19	0.67	17	2.13	54	0.13	60
SY04C1	1/4	0.75	19	0.67	17	2.13	54	0.13	60
SY0506C1	3/8	0.87	22	0.67	17	2.32	59	0.17	75

Standard product – Material: SS or SC equivalent steel, Surface: Zinc plating or chromate treatment

# BRIDGESTONE SELFIT

## FT·FS·FU series

- Compatible fluid  
Mineral Oil
- Inner Tube (SPL)  
Polyester
- Outer Cover (SPL)  
Polyurethane
- Temperature Range : fluid  
-30°C to +80°C / -22°F to +176°F \*1
- Temperature Range : ambient  
-30°C to +70°C / -22°F to +158°F

## FR series

- Compatible Fluid  
Mineral Oil
- Inner Tube (SPL)  
Polyester
- Outer Cover (SPL)  
Polyurethane
- Temperature Range : fluid  
-30°C to +100°C / -22°F to +212°F \*2
- Temperature Range : ambient  
-30°C to +70°C / -22°F to +158°F

- 1 Repair on-site**
- 2 No crimpers required**
- 3 Easy piping work in limited area**
- 4 No external power source required**

\*1 You can use the SPL02 at 100°C / 212°F. If you use couplings FT04, FT06, or FT08 at 100°C / 212°F, the maximum working pressure is 10.5MPa.  
\*2 Note that the figure is different from those for KF series hoses assembled with crimping-type couplings.

## Applicable hose

SPL	Catalog Number	I.D.		O.D.		FT Max.W.D.		FS·FU Max.W.D.		Min.B.P.		Min.B.R.		Weight		Reinforcement
		inch	mm	inch	mm	psi	MPa	psi	MPa	psi	MPa	inch	mm	lbs/ft	g/m	
Maximum Working Pressure <b>10.5-20.5MPa</b> <b>1,500-3,000PSI</b>	SPL02	1/8	3.2	0.31	7.9	3,000	20.5 <sup>*3</sup>	—	—	12,000	82.0	0.47	12	0.03	50	1P
	SPL04	1/4	6.3	0.42	10.6	2,000	14.0	1,500	10.5	8,000	56.0	1.38	35	0.04	60	2C
	SPL06	3/8	9.5	0.60	15.2							2.17	55	0.08	120	1P
	SPL08	1/2	12.7	0.74	18.9	1,500	10.5	6,000	42.0	2.76	70	0.11	170			

\*3 The SPL02 can withstand a maximum shock pressure of 27.5MPa. For other hoses, do not exceed the maximum working pressure.

●The SPL02 and the other hoses have survived impulse testing performed 400,000 times using a flat waveform and a maximum shock pressure of 27.5MPa for SPL02, and under the maximum working pressure for the other hoses. ●Be careful when using the FS or FU series of Bridgestone SELFIT couplings. ●SPL series cut hoses are also available. They are SPL02/04/06 (20m hose: SPLXX-20, 100m hose: SPLXX-100) and the SPL08 (10m hose: SPL08-10, 50m hose: SPL08-50). ●Hoses and fittings cannot be recycled.

One end of an SPL hose can be equipped with a crimped coupling and the other end with a SELFIT coupling. The maximum working pressure and the minimum burst pressure for an SPL hose with these couplings are as specified above. Pressurizing this SPL hose to a working pressure exceeding the maximum could cause it to burst or blow the couplings off. Severe personal injury or death may result if these instructions are not followed.



## Couplings

### FT series [for only SPL]

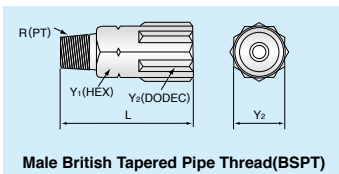

Catalog Number	Thread	Y1		Y2		(L)		Weight	
		inch	mm	inch	mm	inch	mm	lbs	g
FT02R	1/8	0.55	14	0.55	14	1.81	46	0.08	35
FT04R	1/4	0.67	17	0.67	17	1.85	47	0.11	50
FT06R	3/8	0.87	22	0.87	22	2.28	58	0.20	90
FT08R	1/2	1.06	27	1.06	27	2.64	67	0.35	160

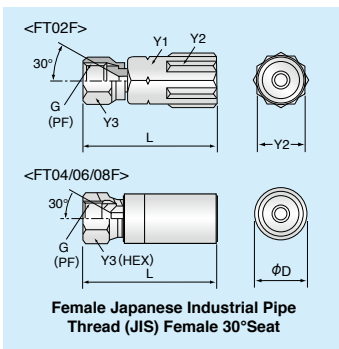

Catalog Number	Thread	Y1		Y2		Y3		φD <sup>*4</sup>		(L)		Weight	
		inch	mm	inch	mm	inch	mm	inch	mm	inch	mm	lbs	g
FT02F	1/8	0.55	14	0.55	14	0.55	14	—	—	2.05	52	0.09	40
FT04F	1/4	—	—	—	—	0.75	19	0.75	19	2.09	53	0.17	75
FT06F	3/8	—	—	—	—	0.87	22	0.94	24	2.44	62	0.24	110
FT08F	1/2	—	—	—	—	1.06	27	1.18	30	2.85	70	0.44	200

## Reinforcing



1 polyester braid



2 textile spiral



## Couplings

FS•FU series [for only SPL]

**R**

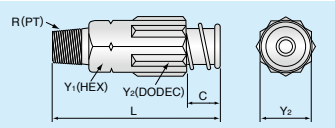

Male British Tapered Pipe Thread (BSPT)

Catalog Number	Thread	Y1		Y2		C		(L)		Weight	
		inch	mm	inch	mm	inch	mm	inch	mm	lbs	g
FS04R	1/4	0.67	17	0.67	17	0.39	10	2.24	57	0.11	50
FS06R	3/8	0.87	22	0.87	22	0.47	12	2.76	70	0.21	95
FS08R	1/2	1.06	27	1.06	27	0.51	13	3.15	80	0.40	180

**F**

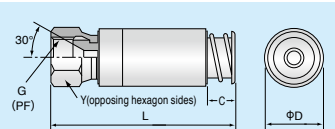

Female Japanese Industrial Pipe Thread (JIS) Female 30° Seat

Catalog Number	Thread	φD		Y		C		(L)		Weight	
		inch	mm	inch	mm	inch	mm	inch	mm	lbs	g
FU04R	1/4	0.75	19	0.75	19	0.39	10	2.48	63	0.17	75
FU06R	3/8	0.94	24	0.87	22	0.47	12	2.91	74	0.25	115
FU08R	1/2	1.18	30	1.06	27	0.51	13	3.23	82	0.45	205

## Adapters

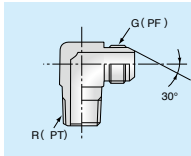

Catalog Number	Thread	Weight	
		lbs	g
8021RG02H14	1/8	0.07	30
8021RG04	1/4	0.11	50
8021RG06	3/8	0.22	100
8021RG08	1/2	0.35	160

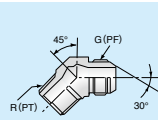

Catalog Number	Thread	Weight	
		lbs	g
8023RG02H14	1/8	0.07	30
8023RG04	1/4	0.11	50
8023RG06	3/8	0.18	80
8023RG08	1/2	0.26	120

## Applicable hose

<b>KF</b> Maximum Working Pressure <b>14.5-20.5MPa</b> <b>2,000-3,000PSI</b>														
	Catalog Number	I.D.		O.D.		Max.W.D.		Min.B.P.		Min.B.R.		Weight		Reinforcement
		inch	mm	inch	mm	psi	MPa	psi	MPa	inch	mm	lbs/ft	g/m	
<b>KF04</b>	1/4	6.3	0.49	12.4	3,000	20.5	12,000	82.0	1.38	35	0.24	110		
<b>KF06</b>	3/8	9.5	0.65	16.6	2,500	16.0*	9,000	62.0*	1.77	45	0.35	160		
<b>KF08</b>	1/2	12.7	0.81	20.6	2,000	14.0	8,000	56.0	2.56	65	0.55	250		

※ Note that the figure is different from those for KF06 hoses assembled with crimping-type couplings.  
 ● All KF series hoses have survived impulse testing performed 400,000 times using a flat waveform under the maximum working pressure.  
 ● Hoses and fittings cannot be recycled.

⚠ Warning One end of a KF hose can be equipped with a crimped coupling and the other end with a Bridgestone SELFIT coupling. The maximum working pressure and the minimum burst pressure for a KF hose with these couplings are as specified above. Pressurizing the KF hose to a working pressure exceeding the maximum could burst the KF hose or remove the couplings from it. Severe personal injury or death may result if these instructions are not followed.

## Couplings FR series [for KF]

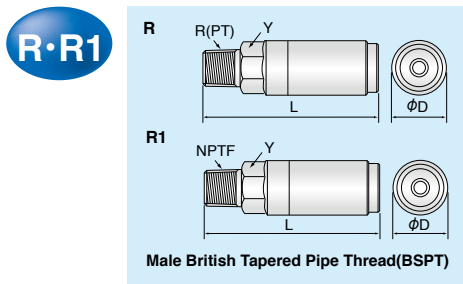

Catalog Number	Thread	Y1		ΦD		(L)		Weight	
		inch	mm	inch	mm	inch	mm	lbs	g
<b>FR04R</b>	1/4	0.75	19	0.83	21.0	2.80	71	0.22	100
<b>FR06R</b>	3/8	0.87	22	1.00	25.4	2.99	76	0.30	135
<b>FR08R</b>	1/2	1.06	27	1.25	31.8	3.50	89	0.55	250
<b>FR04R1</b>	1/4-18	0.75	19	0.83	21.0	2.83	72	0.21	95
<b>FR06R1</b>	3/8-18	0.87	22	0.98	25.0	2.95	75	0.30	135
<b>FR08R1</b>	1/2-14	1.06	27	1.26	32.0	3.54	90	0.53	240

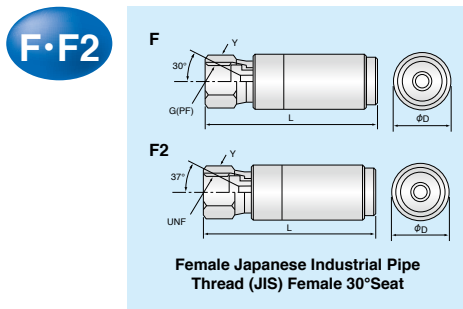

Catalog Number	Thread	Y1		ΦD		(L)		Weight	
		inch	mm	inch	mm	inch	mm	lbs	g
<b>FR04F</b>	1/4	0.75	19	0.83	21.0	2.60	66	0.21	95
<b>FR06F</b>	3/8	0.87	22	1.00	25.4	2.72	69	0.29	130
<b>FR08F</b>	1/2	1.06	27	1.25	31.8	3.15	80	0.55	250
<b>FR04F2</b>	7/16-20	0.75	19	0.83	21.0	1.85	47	0.21	95
<b>FR06F2</b>	9/16-18	0.87	22	1.00	25.4	2.28	58	0.29	130
<b>FR08F2</b>	3/4-16	1.06	27	1.25	31.8	2.64	67	0.52	235

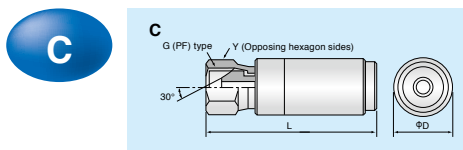

Catalog Number	Thread	Y1		ΦD		(L)		Weight	
		inch	mm	inch	mm	inch	mm	lbs	g
<b>FR04C</b>	1/4	0.75	19	0.83	21.0	2.60	66	0.21	95

## Adapters

For F-Type Threads

Catalog Number	Thread	Weight	
		ibs	g
<b>8021RG04</b>	1/4	0.11	50
<b>8021RG06</b>	3/8	0.22	100
<b>8021RG08</b>	1/2	0.35	160

For F-Type Threads

Catalog Number	Thread	Weight	
		ibs	g
<b>8023RG04</b>	1/4	0.11	50
<b>8023RG06</b>	3/8	0.18	80
<b>8023RG08</b>	1/2	0.26	120

For C-Type Threads

Catalog Number	Thread	Weight	
		ibs	g
<b>8022RG04</b>	1/4	0.13	60

For C-Type Threads

Catalog Number	Thread	Weight	
		ibs	g
<b>8024RG04</b>	1/4	0.09	40

## Reinforcing

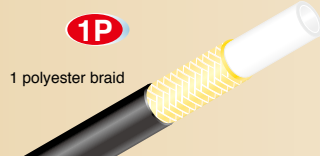

# How to Use FT, FS, FU, and FR Series Couplings

## 1 | Screwing the Couplings

### (1) R (Male British Tapered Pipe Thread (BSPT)) Type

Use a wrench or socket wrench to screw the couplings into equipment, using the tightening torques listed below.  
 •An impact wrench can also be used for fitting couplings.

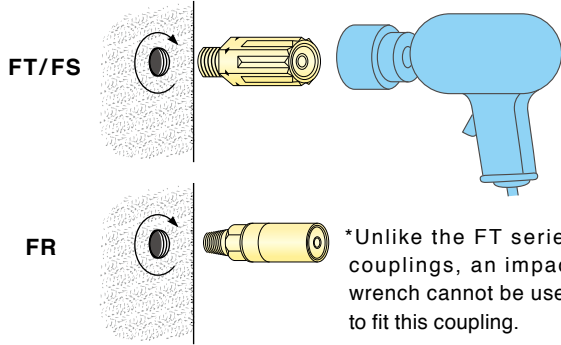

### (2) F (Female Japanese Industrial Pipe Thread (JIS) Female 30° seat) Type

Union nut couplings can be used for elbow piping.

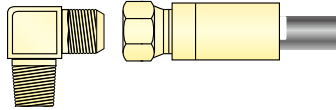

Tightening torques for the FT, FS, and FU series

Tightening torques for the FR series

Size	R tightening torque (N·m)	Size	F tightening torque (N·m)	Size	R tightening torque (N·m)	Size	F tightening torque (N·m)
02R	15	02F	15	04R	25	04F	25
04R	25	04F	25	06R	34	06F	34
06R	34	06F	34	08R	64	08F	64
08R	64	08F	64				

※Wrap sealing tape around the R thread.

## 2 | Determining the Hose Length

The hose is pushed out of this coupling when pressurized. Determine the hose length by considering the displacement.

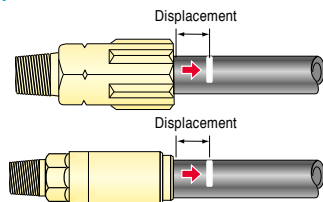

Size	FT series		FS/FU series		FR series	
	Displacement (mm) due to pressure	Pressure (MPa)	Displacement (mm) due to pressure	Pressure (MPa)	Displacement (mm) due to pressure	Pressure (MPa)
02	About 12	About 11	—	—	—	—
04	About 11	About 15	About 11	10.5	About 16	20.5
06	About 15	About 16	About 15		About 18	16.0
08	About 16	About 16	About 16		About 21	14.0

## 3 | Cutting the Hose

Use a hose cutter or a knife to cut the hose perpendicular to its axis.

### ⚠ Caution

Cutting the hose at an angle of more than 10° could cause oil leakage or cause remove the couplings from it.

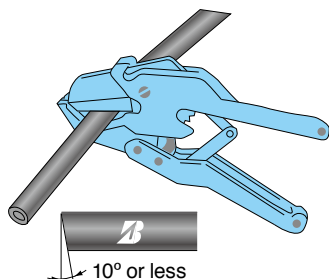

## 4 | Markings

Mark the hose with a white pen to ensure it is fully inserted into the coupling. The table below specifies the length from the end of the hose to the mark.

Size	Inserted hose length (mm)	
	FT series	FS/FU series
02	27	—
04	26	36
06	33	45
08	40	53

Size	Inserted hose length (mm)
	FR series
04	37.5
06	40.5
08	49

\*As the figure to the right shows, the length from the notch on the coupling to the end of the coupling is equal to the inserted hose length.

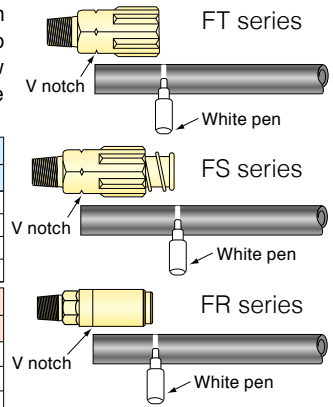

## 5 | Inserting a Hose

Insert the hose into a coupling on the equipment until the hose insertion mark reaches the end of the coupling. Make sure the hose is not extracted after it is inserted.

### ⚠ Caution concerning FT and FR

You cannot detach the hose from the coupling once it is inserted.

### ⚠ Caution concerning FS and FU

You cannot detach the hose from the coupling once it is pressurized.

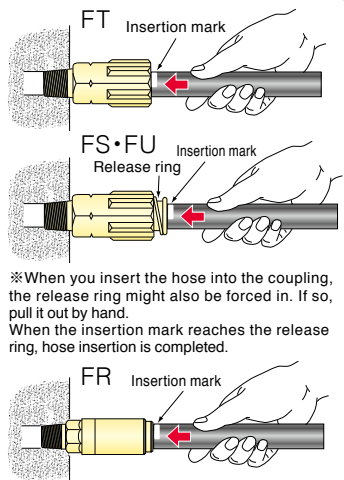

## Removing FS and FU Series Hoses from Couplings

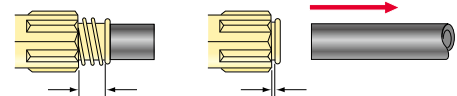

Before it has been pressurized, the hose can be removed from the coupling. Insert the hose into the coupling, and then, while pressing the release ring onto the coupling by hand, pull the hose back out. If removing the hose is difficult, repeat these steps.

## 6 | Detaching the Coupling from Equipment

### (1) R (Male British Tapered Pipe Thread (BSPT)) Type

When the hose is not pressurized, the hose and coupling can rotate freely. To detach the coupling from the equipment, use a wrench to turn the coupling.

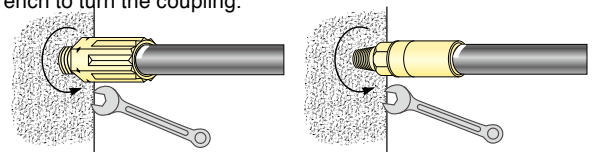

### (2) R (Female Japanese Industrial Pipe Thread (JIS) Female 30° seat) Type



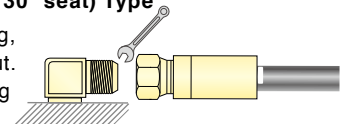

For the union nut coupling, use a wrench to turn the nut. This detaches the coupling from the equipment.





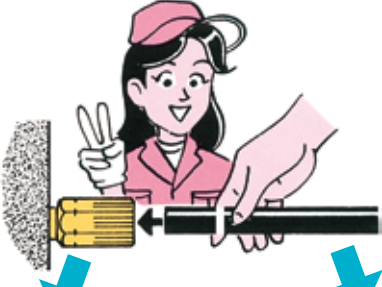

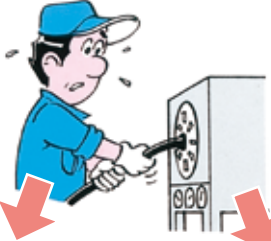
## Features of the FT, FS, FU, and FR Series

These series of couplings have made innovative changes to the conventional coupling assembly process.

### 1. Crimping process eliminated ——— save labor and energy

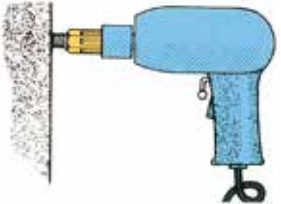
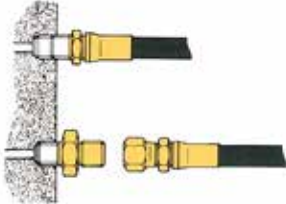
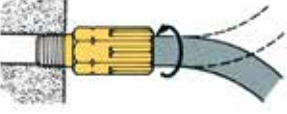
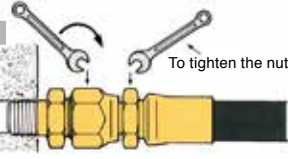
Bridgestone SELFIT	Conventional
<p>You can assemble the hose simply by inserting it into the coupling.</p>  <p>*Except the FR series</p> <p>You can easily assemble the hose by yourself.</p> <p>You can attach hoses in areas with limited space.</p> <p>Crimping machine not required</p> <p>You can attach a hose after simply installing the coupling.</p> 	<p>You use a machine to crimp the coupling.</p>  <p>An assembly company or a person familiar with a crimping machine is responsible for crimping the couplings.</p> <p>Installing only the couplings is impossible.</p>  <p>You cannot install hoses in areas with limited space.</p> 

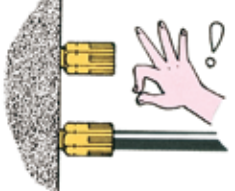
### 2. Easy piping ——— optimal for field adjustment

<p><b>Bridgestone SELFIT</b></p> <p>You can use an impact wrench to install the R type couplings.</p> <p>※Except the FR series.</p> 	<p><b>Conventional</b></p> <p>You cannot use an impact wrench or a socket wrench.</p> 	<p><b>Bridgestone SELFIT</b></p> <p>The couplings can rotate when no pressure is applied.</p> <p>You can install the hose without worrying about twists.</p> <p>You can easily detach the couplings from the equipment.</p> 	<p><b>Conventional</b></p> <p>You have to tighten the intermediate hex nut with a wrench to prevent the hose from twisting.</p> <p>To tighten the nut</p> 
<p><b>Bridgestone SELFIT</b></p> <p>You can install the hose by tightening two parts.</p> <p>No adapter is required.</p> 	<p><b>Conventional</b></p> <p>You need to tighten at least three parts. One or more adapters are required.</p> 	<p><b>Bridgestone SELFIT</b></p> <p>You can install the hose after fixing the couplings to the equipment or after inserting the hose into the couplings.</p> 	<p><b>Conventional</b></p> <p>You can install the hose only after crimping the couplings.</p> 

# BRIDGESTONE PRIMOLINE

Ultra high pressure hose

● Only Hose Assembly Available

## JAT and JAM series

The JAT and JAM series are intended for use with water jets—ultra-high pressure hoses—which have been attracting attention recently. The minimum burst pressure is 650MPa for the JAT series and 490 to 588MPa for the JAM series.

## JAL series

The JAL series is intended mainly for use with jacks and high-pressure cleaning tools. They offer high flexibility and working efficiency.

## JAK and JKY series

The JAT and JAM series are intended mainly for use with jacks. The unique reinforcing used in their structure makes them flexible. They are lightweight hoses, weighing about half the weight of a conventional hose. With the outer diameter and the bending radius 20% to 30% smaller than those of our other products, these are very easy to use.

## ■ Safety Measures <Accessories>

Bore	Hose	Safety chain	Safety net	Bore	Hose	Safety chain	Safety net	Safety chain
03	JAT03	80SAF16CL162	8XND10X600	05	JAM05	80SAF17CL162	8XND13X810	
	JAM03	80SAF14CL162	Snap hook: 8ZGB6G (sold separately)	06	JAL06	-	Snap hook: 8ZGB8G (sold separately)	
	JAL03	-	The safety nets cannot be installed after hose joint assembly. (They cannot be sold separately.)		JAK06	-	The safety nets for 22 hex or smaller nuts can be installed after hose joint assembly. (The safety nets can be sold separately.)	
04	JAL04	80SAF13CL162		The safety nets cannot be installed after hose joint assembly. (They cannot be sold separately.)	08	JAL08		-
	JAK04	-				JAK08		-
	JKY04	-	10		JAL10	-	8XND22X1120 Snap hook: 8ZGB11G (sold separately)	
05	JAL05	-		12	JAL12	-	The safety nets for 36 hex or smaller nuts can be installed after hose joint assembly. (The safety nets can be sold separately.)	
	JAK05	-	16	JAL16	-			

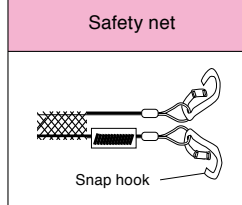

### <Safety Hole in Joint Nut>

This hole is basically intended to easily detect small amounts of leakage. Because the liquid dripping from this hole looks like a teardrop, this hole is called a teardrop hole. If actions such as tightening or replacing parts are not taken when a small amount of leakage is detected, the leakage may increase, resulting in liquid ejection. Liquid (water) ejected from the seat may fill joint and the liquid pressure may cause the joint to swell, damaging the joint (threaded part and hex nut). Finally, the joint may detach from the hose. To prevent this problem, the safety hole performs the function of checking for small amounts of leakage. In addition, it allows liquid to escape from the joint, decreasing the pressure and thus preventing the joint (coupling) from detaching from the hose in the case that ejected liquid fills the joint.

## ■ Maximum Working Pressure for the Joint (Bridgestone PrimoLine)

Joint type	Size	Unit: MPa				
		04	06	08	12	16
R		98.0	68.5	68.5	68.5	68.5
Q、G	*1	196.0	127.5	98.0	88.0	68.5
G4•C5	*2	—	—	294.0	—	—
J4		—	—	245.0	—	—
J5	*3	—	—	294.5	—	—

\*1: The maximum pressure for the ultra high pressure G joint is different from that for the ordinary high-pressure G joint.

\*2: Only a 30 hex nut can be used for a C5 joint at 294.0MPa (JAT05). (A 27 hex nut can be used for pressures of 245.0MPa or lower.)

\*3: Only a titanium-alloy core can be used for a J4 joint at 294.0MPa (JAT03). For a steel or SUS630 core, a joint rated at 245.0MPa can be used.

## ■ Tightening Torques (for Bridgestone PrimoLine)

For information about the tightening conditions, refer to page 82. Unit: N·m

Joint type	Size	Unit: N·m				
		04	06	08	12	16
R*1 (reference values)		30	40	70	180	300
Q、G		37	74	88	132	196
G4•C5		—	—	98	—	—
J4		—	—	39	—	—
J5		—	—	49	—	—

1: Use the tightening torques shown in the table on the left when tightening joints. (The torque tolerance for coupling joints is  $\pm 10\%$ .)

2: Use these tightening torques when the following conditions coexist:  
 - There is no oil left on either the threaded part or the inside of the nut.  
 - The core hex nut is tightened with a wrench to prevent the coupling from rotating.  
 For information about other tightening torques, contact us.

\*1: The tightening torque for the R joint varies depending on how its sealing tape is wrapped. Therefore, the values shown in the table are for reference only.

For water Jet application

- Compatible fluid / Mineral hydraulic Oil, Water
- Inner Tube / Special plastics
- Outer Cover / Nylon 12
- Temperature Range : fluid  
-40°C to +50°C (-40°F to +122°F)(Mineral Oil) / 0°C to +50°C (32°F to +122°F)(Water)
- Temperature Range : ambient  
-40°C to +50°C / -40°F to +122°F

JAT/JAM	I.D.		O.D.		Max.W.P.		Min.B.P.		Min.B.R.		Weight		Reinforcement	Compatible coupling/relevant page Factory-assembled
	inch	mm	inch	mm	psi	MPa	psi	MPa	inch	mm	lbs/ft	g/m		
<b>JAT03</b>	3/16	5.0	0.61	15.6	43,000	294.0	94,500	650.0	15.7	400	1.48	670	8S	BN
<b>JAM03</b>	3/16	5.0	0.54	13.7	35,500	245.0	85,500	588.0	5.91	150	1.06	480	6S	BX
<b>JAM05</b>	5/16	8.0	0.69	17.6	35,500	245.0	71,000	490.0	7.48	190	1.66	750		

\*The standard color for the JAM05 outer cover is gray. Use a pressure waveform (jack waveform) that can withstand shock pressure.

## Couplings

Materials: SS or SC equivalent steel  
Surface: Zinc plating or chromate treatment

G4  
C5

G4 type

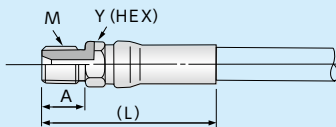

C5 type

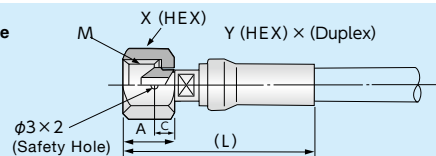

Catalog Number	Thread	Y		A		L		Weight	
		inch	mm	inch	mm	inch	mm	lbs	g
<b>BX0308G4</b>	M22x1.5	0.87	22	0.71	18	3.11	79	0.39	175
<b>BX0508G4</b>		0.94	24	0.71	18	3.42	87	0.49	220

Catalog Number	Thread	X		Y		A		C		L		Weight	
		inch	mm	inch	mm	inch	mm	inch	mm	inch	mm	lbs	g
<b>BX0308C5</b>	M22x1.5	1.06	27	0.55	14	1.02	26	0.28	7	3.50	89	0.43	195
<b>BX0508C5</b>		1.06	27	0.55	14	1.02	26	0.28	7	3.86	98	1.85	245

BI couplers (easily attachable/detachable joints) are available for the couplings above. Refer to the BI coupler catalog. 245.0MPa coupling [Catalog number: 30JA04G4M4-SKFZ]

J5  
J4

J5/J4 type

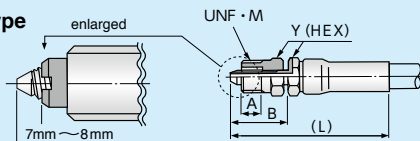

\*Set the sleeve at the first or second thread from the top (approx 7mm)

Catalog Number	Thread	Y		A		B		L		Weight	
		inch	mm	inch	mm	inch	mm	inch	mm	lbs	g
<b>BN0308J5X107</b>	UNF	0.86	22	0.59	15	1.50	38	3.90	99	0.40	180
<b>BX0308J5</b>	3/4-16	0.86	22	0.59	15	1.50	38	3.90	99	0.43	195
<b>BX0508J4</b>	M22x1.5	0.86	22	0.63	16	1.50	38	4.25	107	0.55	250

\*For water use, special alloy is recommended because of stronger resistance against corrosion.

\*BN0308J5X107 is only available for special alloy.

## Reinforcing

6S

6 spiral wires

8S

8 spiral wires

For Hydraulic Jack application

- Compatible fluid / Mineral hydraulic Oil, Water
- Inner Tube / Special plastics(JAL03~05), Nylon 12(JAL06~16)
- Outer Cover / Nylon 12
- Temperature Range : fluid  
-40°C to +50°C (-40°F to +122°F)(Mineral Oil) / 0°C to +50°C (32°F to +122°F)(Water)
- Temperature Range : ambient  
-40°C to +50°C / -40°F to +122°F

JAL	I.D.		O.D.		Max.W.P.		Min.B.P.		Min.B.R.		Weight		Reinforcement	Compatible coupling/relevant page	
	inch	mm	inch	mm	psi	MPa	psi	MPa	inch	mm	lbs/ft	g/m			Factory-assembled
JAL03	3/16	5.0	0.44	11.1	28,500	196.0	57,000	392.0	4.53	115	0.57	260	4S	BL	
JAL04	1/4	6.3	0.50	12.6	21,500	147.0	45,500	313.5	5.71	145	0.64	290		BK	
JAL05	5/16	8.0	0.60	15.2	18,500	127.5	42,500	294.0	6.50	165	0.84	380		AK	
JAL06	3/8	9.8	0.71	18.0	17,000	117.5	37,000	255.0	6.69	170	1.21	550		AL	
JAL08	1/2	12.8	0.83	21.0	14,000	98.0	34,000	235.0	7.48	190	1.57	710			
JAL10	5/8	16.3	0.98	25.0	13,000	88.0	31,000	215.0	8.27	210	2.31	1,050			
JAL12	3/4	20.0	1.15	29.2	10,500	73.5	25,500	176.5	9.45	240	2.56	1,160			
JAL16	1	25.0	1.42	36.0	10,000	68.5	21,500	147.0	11.02	280	3.33	1,510			

\*Use a pressure waveform (jack waveform) that can withstand shock pressure.

Couplings

Materials: SS or SC equivalent steel  
Surface: Zinc plating or chromate treatment

G/G4  
R4  
Q

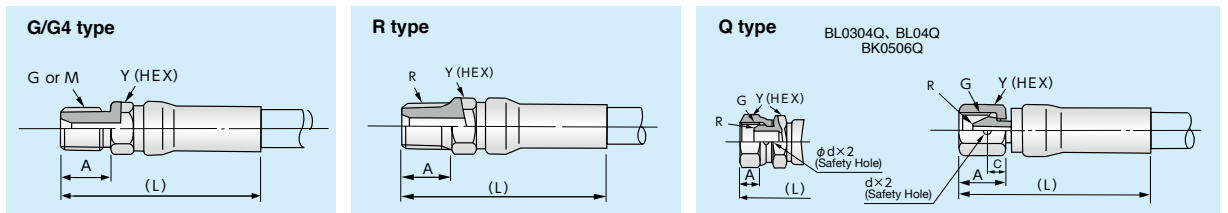

Catalog Number	Thread	Y		A		L		Weight		Catalog Number	Thread	Y		A		L		C		φd		Weight	
		inch	mm	inch	mm	inch	mm	lbs	g			inch	mm	inch	mm	inch	mm	inch	mm	inch	mm	lbs	g
BL0304G	G1/4	0.75	19	0.51	13	2.68	68	0.19	85	BL0304Q	1/4	0.75	19	0.39	10	2.80	71	0.22	5.5	0.08	2.0	0.21	95
BL0308G4	M22×1.5	0.87	22	0.71	18	2.91	74	0.30	135	BL04Q	1/4	0.75	19	0.39	10	2.91	74	0.22	5.5	0.08	2.0	0.23	105
BL04G	G1/4	0.75	19	0.51	13	2.68	68	0.20	90	BK0506Q	3/8	0.87	22	0.39	10	2.87	73	0.22	5.5	0.10	2.5	0.28	125
BK0506R	R3/8	0.87	22	0.59	15	2.72	69	0.24	110	AK06Q	3/8	0.87	22	0.75	19	2.76	70	0.26	6.7	0.10	2.5	0.31	140
AK06R	R3/8	0.87	22	0.59	15	2.83	72	0.30	135	AL06Q	3/8	0.87	22	0.75	19	2.76	70	0.26	6.7	0.10	2.5	0.31	140
AL08R	R1/2	1.06	27	0.71	18	4.13	105	0.72	325	AL08Q	1/2	1.06	27	0.87	22	4.02	102	0.28	7.0	0.12	3.0	0.73	330
AL1012G	G3/4	1.42	36	0.79	20	4.45	113	1.01	460	AL1012Q	3/4	1.42	36	0.98	25	4.21	107	0.35	9.0	0.14	3.5	0.90	410
AL12G	G3/4	1.42	36	0.79	20	4.33	110	1.19	540	AL12Q	3/4	1.42	36	1.06	27	4.29	109	0.35	9.0	0.14	3.5	1.23	560
AL16G	G1	1.61	41	0.87	22	4.69	119	1.50	680	AL16Q	1	1.61	41	1.10	28	4.41	112	0.35	9.0	0.14	3.5	1.54	700

4S

4 spiral wires



For Hydraulic Jack application

- Compatible fluid / Mineral hydraulic Oil
- Inner Tube / Nylon 12
- Outer Cover / Polyurethane
- Temperature Range : fluid / -40°C to +80°C (-40°F to +176°F)
- Temperature Range : ambient / -40°C to +70°C / -40°F to +158°F

JKY/JAK	I.D.		O.D.		Max.W.P.		Min.B.P.		Min.B.R.		Weight		Reinforcement	Compatible coupling/relevant page Factory-assembled
	inch	mm	inch	mm	psi	MPa	psi	MPa	inch	mm	lbs/ft	g/m		
	<b>JKY04</b>	1/4	6.3	0.50	12.7	10,000	68.5	24,000	166.5	2.17	55	0.46		
<b>JAK04</b>	1/4	6.3	0.51	13.0	14,000	98.0	35,500	245.0	2.17	55	0.68	310	2S+1W	AK
<b>JAK05</b>	5/16	8.2	0.56	14.1	10,000	68.5	25,500	176.5	3.15	80	0.71	320		BK
<b>JAK06</b>	3/8	10.0	0.68	17.3	10,000	68.5	22,500	156.5	3.94	100	0.88	400		AK
<b>JAK08</b>	1/2	12.8	0.80	20.2	10,000	68.5	21,500	147.0	5.12	130	1.19	540		

\*Use a pressure waveform (jack waveform) that can withstand shock pressure.

## Couplings

Materials: SS or SC equivalent steel  
Surface: Zinc plating or chromate treatment

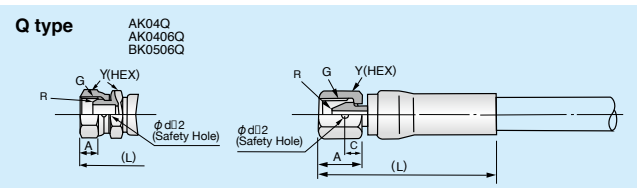
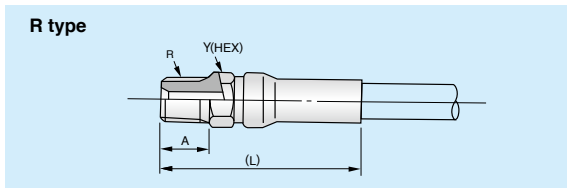

Catalog Number	Thread	Y		A		L		Weight	
		inch	mm	inch	mm	inch	mm	lbs	g
<b>UY0406R</b>	3/8	0.75	19	0.59	15	2.24	57	0.14	65
<b>AK04R*</b>	1/4	0.75	19	0.51	13	2.36	60	0.17	75
<b>AK0406R</b>	3/8	0.87	22	0.59	15	2.48	63	0.20	90
<b>BK0506R</b>	3/8	0.87	22	0.59	15	2.83	72	0.24	110
<b>AK06R</b>	3/8	0.87	22	0.59	15	2.83	72	0.30	135
<b>AK08R</b>	1/2	1.06	27	0.71	18	3.15	80	0.45	205

Catalog Number	Thread	Y		A		L		C		φd		Weight	
		inch	mm	inch	mm	inch	mm	inch	mm	inch	mm	lbs	g
<b>AK04Q*</b>	1/4	0.75	19	0.39	10	2.60	66	-	-	-	-	0.20	90
<b>AK0406Q</b>	3/8	0.87	22	0.39	10	2.64	67	-	-	-	-	0.24	110
<b>BK0506Q</b>	3/8	0.87	22	0.75	19	2.87	73	0.22	5.5	0.10	2.5	0.28	125
<b>AK06Q</b>	3/8	0.87	22	0.75	19	2.76	70	0.26	6.7	0.10	2.5	0.31	140
<b>AK08Q</b>	1/2	1.06	27	0.87	22	3.07	78	0.28	7.0	0.12	3.0	0.46	210

\*Couplings marked with an asterisk are available on request. Use the 30° female seat type adapter by Bridgestone with the Q type coupling.

◇BI couplers (easily attachable/detachable joints) for AK04R, AK0406R, BK0506R, AK06R, and AK08R are available. Refer to the BI coupler catalog.

68.5MPa couplings

Catalog number. 30JCA06C-XXZ  
30JCA04C-XXZ\*  
30JCA08C-XXZ\*  
\*Special products

## Reinforcing





## ■ Connection Method

### ① To connect J5 type coupling to equipments

Prepare the equipment side as shown in the figure on the right.

● Equipment side

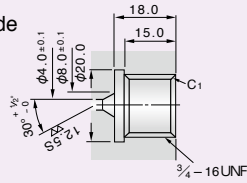

BX0308J5  
BN0308J5

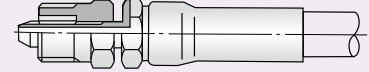

### ② To connect G4 type coupling to equipments

Prepare the equipment side as shown in the figure on the right.

● Equipment side

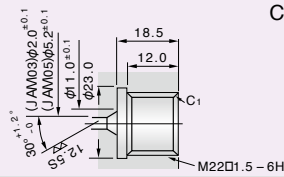

Cone **8083**

BX0308G4  
BX0508G4

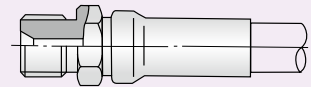

Use Cone **8083** for connection

### ③ To connect C5 type coupling to equipments

Prepare the equipment side as shown in the figure on the right.

● Equipment side

\* Same as 2. To connect G4 type couplings to equipments.

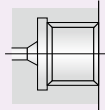

Adapter **8082**

BX0308C5  
BX0508C5

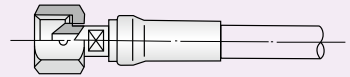
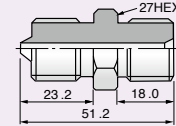

Use adapter **8082** for connection

### ④ To connect two C5 type couplings

Use adapter **8081** for connection

BX0308C5  
BX0508C5

Adapter **8081**

BX0308C5  
BX0508C5

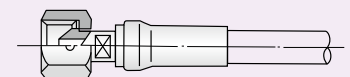
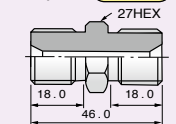

M22□1.5-6g at both end

### ⑤ To connect two J5 type couplings

Use adapter **8084** for connection

BN0308J5X107  
BX0308J5

Adapter **8084**

BN0308J5X107  
BX0308J5

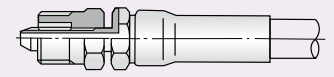
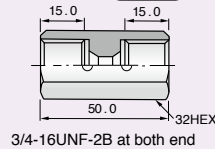

3/4-16UNF-2B at both end

### ⑥ To connect J4 type coupling to equipments

Prepare the equipment side as shown in the figure on the right.

● Equipment side

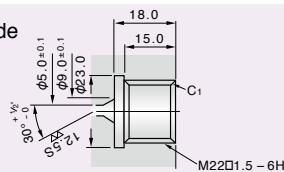

BX0508J4

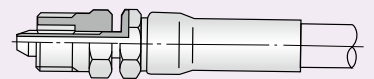

G4 and C5 type couplings can be connected directly to each other.

Use the Q type coupling equipped with adapter **8002RG** under a pressure of 147MPa or lower. \*8022RG or 8024RG cannot be used.

◇ BI couplers (easily attachable/detachable joints) are available for BL0304Q and BL04Q. Refer to the BI coupler catalog. 147.0MPa coupling [Catalog number: 30JA04B-SKFZ]

# Adapters

■ When using an adapter, take into account the outline dimensions of the assembled adapter below when determining the length of the assembly hose. (For the L dimensions, refer to page 5.)

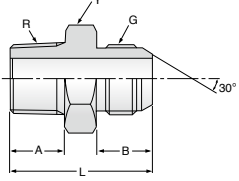
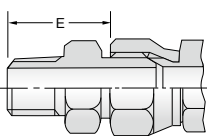
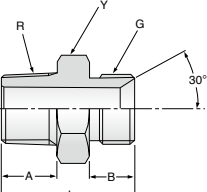
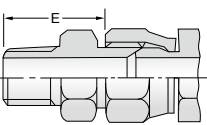
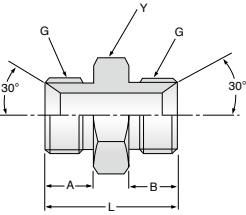
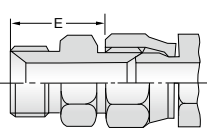
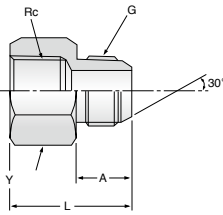
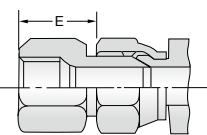
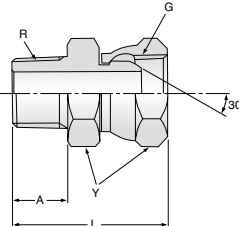
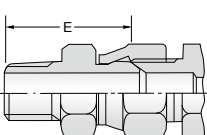
8001RG	Catalog Number	Thread	Y mm	L mm	A mm	B mm	Weight g	Adapter + Coupling	E mm	
 <p>*Brass versions are available for the products marked with an asterisk. For their dimensions, refer to the adapter specifications for the ACT series on page 22.</p>	8001RG02	1/8	14	32	10	14	20		+02F	23
	8001RG04*	1/4	19	37	13	16	40		+04F	26
	8001RG06*	3/8	22	41	15	18	60		+06F	29
	8001RG08*	1/2	27	48	18	20	100		+08F	33
	8001RG12	3/4	36	54	20	22	170		+12F	38
	8001RG16	1	41	58	22	23	240		+16F	42
	8001RG20	1 1/4	50	66	25	27	420		+20F	46
	8001RG24	1 1/2	55	69	25	29	480		+24F	49
	8001RG32	2	70	76	29	30	720		+32F	52
	8001RG40	2 1/2	90	85	32	34	1,300		+40F	56
8002RG	Catalog Number	Thread	Y mm	L mm	A mm	B mm	Weight g	Adapter + Coupling	E mm	
	8002RG04	1/4	19	34	13	13	40		+04C	26
	8002RG06	3/8	22	38	15	15	60		+06C	29
	8002RG08	1/2	27	46	18	18	100		+08C	35
	8002RG12	3/4	36	52	20	20	170		+12C	39
	8002RG16	1	41	57	22	22	240		+16C	44
	8002RG20	1 1/4	50	64	25	25	410		+20C	47
	8002RG24	1 1/2	55	65	25	25	470		+24C	47
	8002RG32	2	70	75	29	29	760		+32C	54
8004GG	Catalog Number	Thread	Y mm	L mm	A mm	B mm	Weight g	Adapter + Coupling	E mm	
	8004GG04	1/4	19	34	13	13	40		+04C	26
	8004GG06	3/8	22	38	15	15	60		+06C	29
	8004GG08	1/2	27	46	18	18	100		+08C	35
	8004GG12	3/4	36	52	20	20	170		+12C	39
	8004GG16	1	41	57	22	22	240		+16C	44
	8004GG20	1 1/4	50	64	25	25	410		+20C	47
	8004GG24	1 1/2	55	65	25	25	470		+24C	47
	8004GG32	2	70	75	29	29	760		+32C	54
8005RG	Catalog Number	Thread	Y mm	L mm	A mm		Weight g	Adapter + Coupling	E mm	
	8005RG04	1/4	19	32	16		40		+04F	21
	8005RG06	3/8	22	37	18		60		+06F	25
	8005RG08	1/2	27	42	20		90		+08F	27
	8005RG12	3/4	36	47	22		180		+12F	31
	8005RG16	1	41	51	23		240		+16F	35
	8005RG20	1 1/4	50	57	27		330		+20F	37
	8005RG24	1 1/2	55	61	29		400		+24F	41
	8005RG32	2	70	65	30		690		+32F	41
8006RG	Catalog Number	Thread	Y mm	L mm	A mm	Max. W.P	Weight g	Adapter + Coupling	E mm	
	8006RG04	1/4	19	40	13	34.5	60		+04G	30
	8006RG06	3/8	22	42	15	34.5	80		+06G	32
	8006RG08	1/2	27	49	18	34.5	130		+08G	37
	8006RG12	3/4	36	57	20	27.5	250		+12G	44
	8006RG16	1	41	63	22	20.5	330		+16G	47
	8006RG20	1 1/4	50	71	25	17.0	500		+20G	53
	8006RG24	1 1/2	55	74	25	10.5	580		+24G	53
	8006RG32	2	70	82.8	29	10.5	1,040		+32G	61

Standard product — Material: SS or SC equivalent steel, Surface: Zinc plating or chromate treatment

8007RG		Catalog Number	Thread	X-Y mm	L mm		Max. W.P	Weight g	Adapter + Coupling		E mm	
	8007RG04	1/4	19	35			34.5	60		+04G	25	
	8007RG06	3/8	22	38			34.5	70		+06G	28	
	8007RG08	1/2	27	43			34.5	110		+08G	31	
	8007RG12	3/4	36	50			27.5	250		+12G	37	
	8007RG16	1	41	56			20.5	290		+16G	40	
	8007RG20	1 1/4	50	62			17.0	420		+20G	44	
	8007RG24	1 1/2	55	66			10.5	490		+24G	45	
	8007RG32	2	70	71.8			10.5	965		+32G	50	
8008RG		Catalog Number	Thread	Y mm	L mm	A mm		Weight g	Adapter + Coupling		E mm	
	8008RG04	1/4	19	29	13			40		+04C	21	
	8008RG06	3/8	22	34	15			50		+06C	25	
	8008RG08	1/2	27	40	18			100		+08C	29	
	8008RG12	3/4	36	45	20			180		+12C	32	
	8008RG16	1	41	50	22			230		+16C	37	
	8008RG20	1 1/4	50	55	25			350		+20C	38	
	8008RG24	1 1/2	55	57	25			410		+24C	39	
	8008RG32	2	70	64	29			680		+32C	43	
8021RG		Catalog Number	Thread	X mm	C mm	E mm	A mm	B mm	Weight g	Adapter + Coupling		E mm
	8021RG02H14	1/8	14	22	21	10	14	30		+02F	12	
	8021RG04	1/4	17	26	25	11	16	50		+04F	13	
	8021RG06	3/8	19	30	28	12	18	100		+06F	16	
	8021RG08	1/2	24	36	32	15	20	160		+08F	17	
	8021RG12	3/4	30	43	37	17	22	250		+12F	21	
	8021RG16	1	36	50	41	19	24	410		+16F	25	
	8021RG20	1 1/4	46	58	50	22	27	730		+20F	30	
	8021RG24	1 1/2	50	63	52	22	27	920		+24F	34	
	8021RG32	2	65	75	63	26	30	1,810		+32F	38	
8022RG		Catalog Number	Thread	X mm	C mm	E mm	A mm	B mm	Weight g	Adapter + Coupling		E mm
	8022RG04	1/4	17	26	22	11	13	60		+04C	13	
	8022RG06	3/8	19	30	25	12	15	90		+06C	16	
	8022RG08	1/2	24	36	30	15	18	150		+08C	19	
	8022RG12	3/4	30	43	35	17	20	260		+12C	22	
	8022RG16	1	36	50	40	19	22	390		+16C	27	
	8022RG20	1 1/4	46	58	48	22	25	740		+20C	30	
	8022RG24	1 1/2	50	63	50	22	25	900		+24C	32	
	8022RG32	2	65	75	62	26	29	1,580		+32C	40	
8023RG		Catalog Number	Thread	X mm	C mm	E mm	A mm	B mm	Weight g	Adapter + Coupling		E mm
	8023RG02H14	1/8	14	18	21	10	14	20		+02F	24	
	8023RG04	1/4	17	19	22	11	16	50		+04F	25	
	8023RG06	3/8	19	22	25	13	18	80		+06F	29	
	8023RG08	1/2	24	26	28	15	20	120		+08F	32	
	8023RG12	3/4	30	30	32	17	22	190		+12F	35	
	8023RG16	1	36	34	36	19	24	300		+16F	41	
	8023RG20	1 1/4	46	40	42	22	27	530		+20F	51	
	8023RG24	1 1/2	50	41	43	22	27	590		+24F	52	
	8023RG32	2	65	50	51	26	30	1,090		+32F	61	
8024RG		Catalog Number	Thread	X mm	C mm	E mm	A mm	B mm	Weight g	Adapter + Coupling		E mm
	8024RG04	1/4	17	19	19	11	13	40		+04C	25	
	8024RG06	3/8	19	22	22	13	15	70		+06C	28	
	8024RG08	1/2	24	26	26	15	18	120		+08C	34	
	8024RG12	3/4	30	30	30	17	20	200		+12C	37	
	8024RG16	1	36	34	34	19	22	300		+16C	42	
	8024RG20	1 1/4	46	40	40	22	25	570		+20C	55	
	8024RG24	1 1/2	50	41	41	22	25	650		+24C	55	
	8024RG32	2	65	50	50	26	29	1,200		+32C	65	

Standard product — Material: SS or SC equivalent steel, Surface: Zinc plating or chromate treatment

# Split flanges

## Split Flange

- 8YK\*\*S : for SAE Standard Pressure Series / bolt thread : UNF
- 8YK\*\*H : for SAE High Pressure Series / bolt thread : UNF
- 8YK\*\*SM\*\* : for SAE Standard Pressure Series / body thread : M
- 8YK\*\*HM\*\* : for SAE High Pressure Series / bolt thread : M
- Figure in [ ] show SAE specification. Though there are some differences in dimension, there are no performance differences.
- Weight below shows that of 1 set.

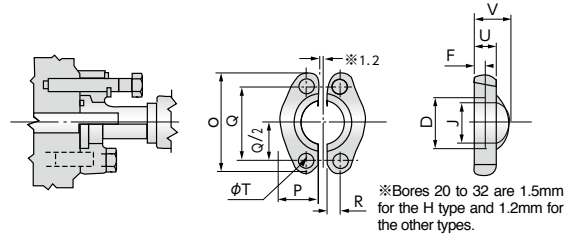

Note: Split flanges for metric screw threads and for unified screw threads differ only in terms of the T dimensions. Other dimensions and the maximum working pressures for these flanges are the same.

Catalog Number	flange	D mm	F mm	J mm	O mm	P mm	Q mm	R mm	T mm	U mm	V mm	Max.W.P. MPa	Weight g	Catalog Number.	T mm	Weight g
8YK08S	1/2	31.0	6.22	24.3	54.0	21.8	38.1	8.0	8.7	13.0	19.0	34.5	180	8YK08S	9.0	180
8YK12S	3/4	38.9	6.22	32.1	65.1	24.9	47.6	10.0	10.3	14.3 [14.0]	22.0	34.5	200	8YK12SM10	10.8	200
8YK16S	1	45.2	7.49	38.5	69.9	28.2	52.4	12.0	10.3	16.0	24.0	34.5	260	8YK16SM10	10.8	260
8YK20S	1 1/4	51.6	7.49	43.7	79.4	35.3	58.7	14.0	11.9	14.3 [14.0]	22.0	27.5	320	8YK20SM12	12.5	320
8YK24S	1 1/2	61.1	7.49	50.8	93.8	40.1	69.9	17.0	13.5	19.1 [16.0]	30.0 [25.0]	20.5	560	8YK24SM12	12.5	560
8YK32S	2	72.2	9.02	62.7	101.6	48.0 [47.2]	77.8	20.2 [21.0]	13.5	19.0 [16.0]	30.0 [26.0]	20.5	720	8YK32SM12	12.5	720
8YK08H	1/2	32.5	7.24	24.6	56.4	22.6	40.5	8.0	8.7	16.0	22.0	41.0	140	8YK08H	8.7	140
8YK12H	3/4	42.1	8.26	32.5	71.4	29.0	50.8	11.0	10.3	19.0	28.0	41.0	320	8YK12HM10	10.5	320
8YK16H	1	48.4	9.02	38.9	81.1	33.8	57.2	13.0	11.9	24.0	32.0 [33.0]	41.0	560	8YK16HM12	12.5	560
8YK20H	1 1/4	54.8	9.78	44.5	95.3	37.6	66.7	14.5 [15.0]	13.5	27.0	34.0 [38.0]	41.0	800	8YK20HM12	12.5	800
8YK24H	1 1/2	64.3	12.07	51.6	112.8	46.5	79.4	17.0	16.7	30.0	43.0	41.0	1,280	8YK24HM14	14.9	1,280
8YK32H	2	80.2	12.07	67.6	133.4	55.9	96.8	21.0	19.8	37.0	52.0	41.0	2,140	8YK32HM20	20.9	2,140

## Bolt for Split Flange

Bolt Thread : UNF	Catalog Number	UNF	Y mm	S mm	ø mm	D mm	H mm	Split Flange
●8YA**S : for SAE Standard Pressure Series ●8YA**H : for SAE High Pressure Series	8YA08S	5/16 -18	12.7	25	31.8	7.94	5.2	8YK08S 8YK08H
	8YA12S	3/8 -16	14.3	25	31.8	9.52	6.0	8YK12S 8YK16S
	8YA20S	7/16 -14	15.9	28	38.1	11.1	7.1	8YK20S
	8YA24S	1/2 -13	19.0	32	38.1	12.7	7.9	8YK24S 8YK32S
	8YA12H	3/8 -16	14.3	25	38.1	9.52	6.0	8YK12H
	8YA16H	7/16 -14	15.9	25	44.5	11.1	7.1	8YK16H
	8YA20H	1/2 -13	19.0	25	44.5	12.7	7.9	8YK20H
	8YA24H	5/8 -11	23.8	32	57.2	15.9	9.9	8YK24H
	8YA32H	3/4 -10	26.8	32	69.8	18.9	11.9	8YK32H
	Washer is included							
Bolt Thread : M	Catalog Number	M	Y mm	S mm	ø mm	D mm	H mm	Split Flange
●8YA**SM** : for SAE Standard Pressure Series ●8YA**HM** : for SAE High Pressure Series	8YA08SM8	M8×1.25	13.0	22.0	30.0	8.0	5.5	8YK08S 8YK08H
	8YA12SM10	M10×1.5	17.0	26.0	30.0	10.0	7.0	8YK12SM10 8YK16SM10
	8YA20SM12	M12×1.75	19.0	30.0	40.0	12.0	8.0	8YK20SM12 8YK24SM12 8YK32SM12
	8YA12HM10	M10×1.5	17.0	26.0	40.0	10.0	7.0	8YK12HM10
	8YA16HM12	M12×1.75	19.0	30.0	45.0	12.0	8.0	8YK16HM12 8YK20HM12
	8YA24HM14	M14×2.0	22.0	34.0	55.0	14.0	9.0	8YK24HM14
	8YA32HM20	M20×2.5	30.0	46.0	70.0	20.0	13.0	8YK32HM20
Washer is included								

## O-ring for Split Flanges

- Hardness : 90(Durometer A)
- Materials : NBR

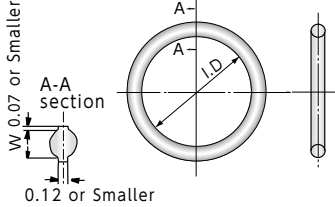

Catalog Number	I-D mm	W mm	SAE J515 or AS568	Split Flange
8YG08S	18.64±0.15	3.53±0.1	210	08S 08H
8YG12S	24.99±0.15	//	214	12S, 12SM10 12H, 12HM10
8YG16S	32.92±0.15	//	219	16S, 16SM10 16H, 16HM12
8YG20S	37.69±0.15	//	222	20S, 20SM12 20H, 20HM12
8YG24S	47.22±0.25	//	225	24S, 24SM12 24H, 24HM14
8YG32S	56.74±0.25	//	228	32S, 32SM12 32H, 32HM20

## Flange for JIS 21 MPa

### Flange for JIS 21MPa

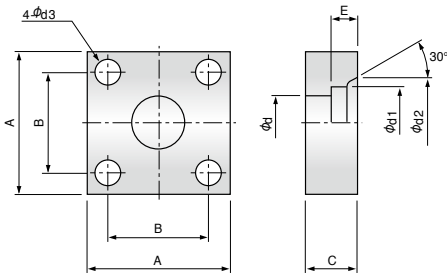

73K1 : JIS SHB compliant.  
73K3 : JIS SSB compliant.

Catalog Number	A mm	B mm	C mm	E mm	d mm	d1 mm	d2 mm	d3 mm	Weight g	Piping OD
73K115	63	40	22	11	16.0	22.2	32	11	530	21.7
73K315	54	36						M10×1.5	400	
73K120	68	45	22	12	20.0	27.7	38	11	600	27.2
73K320	58	40						M10×1.5	450	
73K125	80	53	28	14	25.0	34.5	45	13	1,080	34.0
73K325	68	48						M12×1.75	760	
73K132	90	63	28	16	31.5	43.2	56	13	1,350	42.7
73K332	76	56						M12×1.75	920	
73K140	100	70	36	18	37.5	49.1	63	18	2,030	48.6
73K340	92	65						M16×2	1,750	
73K150	112	80	36	20	47.5	61.1	75	18	2,500	60.5
73K350	100	73						M16×2	1,950	
73K165	140	100	45	22	60	77.1	95	22	4,700	76.5
73K365	128	92						M20×2.5	3,600	
73K180	155	112	45	25	71	90	108	24	5,900	89.4
73K380	140	103						M22×2.5	4,300	

### Bolt for JIS 21 MPa flange

- 8YAK (JIS SHA SHB)  
With nut and washer

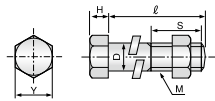

- 8YBK2 (JIS SSA, SSB) ...  
With washer

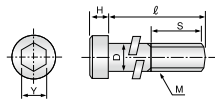

Note) These products cannot be used for loose flanges.

Catalog Number	Y (mm)	M	S mm	φ mm	D mm	H mm	Split Flange
8YAK15	17	M10X	26	60	10	7	K15, K115 K20, K120
8YBK215	8	1.5	32	50		10	K215, K315 K220, K320
8YAK25	19	M12X	30	75	12	8	K25, K125 K32, K132
8YBK225	10	1.75	36	60		12	K225, K325 K232, K332
8YAK40	24	M16X	38	95	16	10	K40, K140 K50, K150
8YBK240	14	2	44	75		16	K240, K340 K250, K350
8YAK65	30	M20X	46	120	20	13	K65, K165
8YBK265	17	2.5	52	95		20	K265, K365
8YAK80	32	M22X	56	130	22	14	K80, K180
8YBK280	17	2.5	50	95		22	K280, K380
8YBM10L65S6	8	M10X	32	65	10	10	K415
8YBM10L70S6	8	1.5	32	70		10	K420
8YBM12L80S6	10	M12X	36	80	12	12	K425
8YBM12L90S6	10	1.75	36	90		12	K432
8YBM16L110S6	14	M16X	44	110	16	16	K440
8YBM16L120S6	14	2	44	120		16	K450

### O-ring for JIS 21 MPa flange

- Hardness : 90(Durometer A)
- Materials : NBR

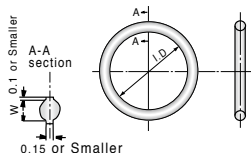

Catalog Number	I-D mm	W mm	JIS Code	Split Flange
8YGK15	24.4±0.15	3.1±0.1	B2401-G25	K15, K215, K415
8YGK20	29.4±0.15	3.1±0.1	B2401-G30	K20, K220, K420
8YGK25	34.4±0.15	3.1±0.1	B2401-G35	K25, K225, K425
8YGK32	39.4±0.15	3.1±0.1	B2401-G40	K32, K232, K432
8YGK40	49.4±0.25	3.1±0.1	B2401-G50	K40, K240, K440
8YGK50	59.4±0.25	3.1±0.1	B2401-G60	K50, K250, K450
8YGK65	74.4±0.4	3.1±0.1	B2401-G75	K65, K265, K465
8YGK80	84.4±0.4	3.1±0.1	B2401-G85	K80, K280, K480

# BI - Coupler

For Safety's sake

Be sure to read the followings before use.

- 1** These Bridgestone products are developed for hydraulic components.  
 Follow each product's application and specification.  
 Avoid burst, leakage and other dangers by following these important steps.

## ① Proper use

**Warning** Severe personal injury or death may result if these instructions are not followed.

- **Do not touch a pressurized coupler or swivel joint.**  
 If a product is broken, and a fluid touches the skin, even if no pain is felt, a serious injury including burns may be caused. Obtain medical assistance immediately. Failure to do so can result in the loss of the injured body part or death. Use of plastic hose guards will increase the possibility to protect a person from injury.
- **System working pressure should not exceed the rated working pressure.**  
 Exceeding the rated working pressure of hose and coupler may result in the hose bursting or hose coupling-blow off. Follow the maximum working pressure ratings listed in this catalog.
- **Do not remove BI coupler under pressurized conditions.**
- **Do not use body or nose of BI coupler as stop valve.**
- **Do not apply an electrical current to a hose assembly**  
 Electrifying may lead to a product failure or electric shock.
- **Use compatible hydraulic fluid**  
 The use of an incompatible hydraulic fluid will deteriorate the inner tube and or the reinforcement, resulting in the hose bursting or hose coupling blow-off
- **Avoid the usage exceeding applicable temperature**  
 The usage exceeding applicable temperature may cause leakage and hose coupling blow-off.
- **Avoid excessive vibration**  
 Excessive vibration may cause leakage and hose coupling blow-off by fatigue.

**Caution** Personal injury or property damage may result if these instructions are not followed

- **Do not take remaining pressure by hitting head portion of poppet of BI coupler**
- **Avoid vacuum pressure**  
 Excessive vacuum pressure may result in the inner tube damage which will lead to hose failure.
- **Never repair or rework.**
- **Avoid submerging hose assemblies in water or any other liquid, to avoid rust.**
- **Do not touch with the bare hand, since the BI coupler may get hot.**

## ② Installation

**Caution**

Follow the below tightening torque. Improper tightening may lead to deterioration of seal performance, oil leakage, and failure of connection portion which may result in injury or material damage.

① In case of steel or stainless

Size	04	06	08	12	16	20	24	32
		1/4"	3/8"	1/2"	3/4"	1"	1 1/4"	1 1/2"
Tightening Torque N·m	25	34	64	132	196	225	255	412

② In case of brass or copper

Size	04	06	08	12	16	20	24	32
		1/4"	3/8"	1/2"	3/4"	1"	1 1/4"	1 1/2"
Tightening Torque N·m	15	25	29	59	88	118	137	206

Please connect a hose at a right angle to the fixed side like (B). Avoid the piping like (A) which may apply too much force on the rotating part.

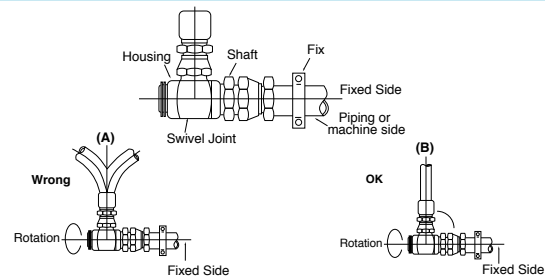

As for installation of swivel joint, fix the shaft side and rotate the housing side.

Do not connect a swivel joint with another swivel joint.

## ③ Warranty Period

Warranty period is impulse cycle number or each specified period, whichever comes earlier.

## ④ Preventive Maintenance

Before every usage, check any leakage from the Products. If found, replace with a new one.

## ⑤ Storage

Store in a dark and dry place at the temperature between -10°C to +40°C (14°F to 104°F)

- **Uses** BI couplers for hydraulic/pneumatic hoses are joints that can be easily attached and detached like an electric plug. With these couplings, you can use various attachments with a single pressure source or easily assemble and disassemble a large machine.

- **Features** Minimize possible fluid leakage and aeration

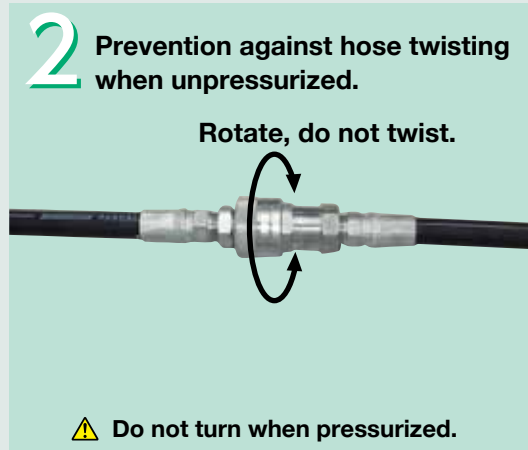
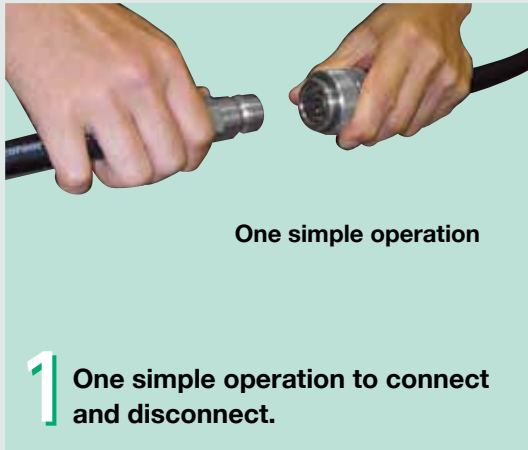

- **Structure**



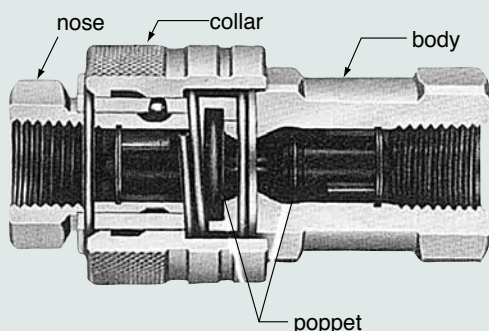







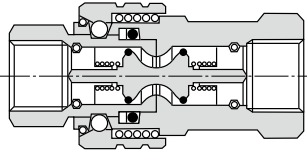

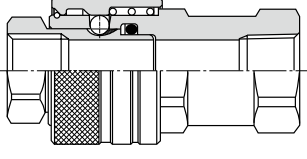
BI coupler is composed of nose, body, collar, and valve frame. When the collar is slid in axial direction, the steel ball can be free and the body and the nose can be inserted. After the insertion, if the collar is moved back, the steel ball is on the line of the nose and BI coupler is locked. In this condition, each poppet is pushed and the circuit is open. For disconnection, when the collar is moved on axial direction, the steel ball is free again and body and nose is easily disconnected. At the time, the poppet adheres to seat surface and the circuit is closed.

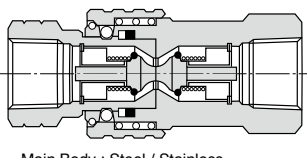

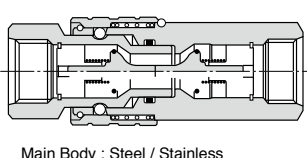

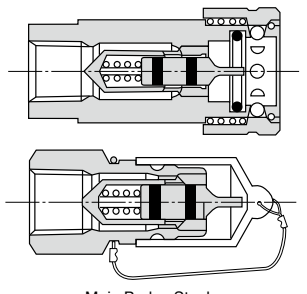

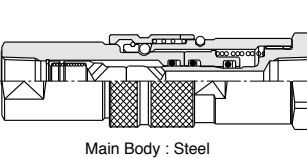

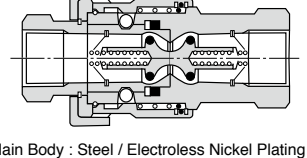

## Ordering Instructions

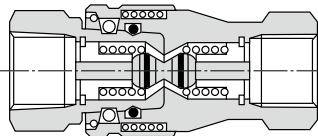
- If you can select an appropriate coupler on the basis of the usage conditions, specify the catalog number by referring to the BI coupler or swivel joint catalog.
- If you ask us to select a coupler or if you need a special coupler, specify the following:
  - Fluid to be used
  - Flow rate and velocity.
  - Fluid temperature
  - Maximum working pressure ( Relief valve pressure )
  - Vibration
  - Installation way ( screw, spanner, etc )
  - Ambient temperature
- A cap plug is required for dust prevention and coupler protection. Order the cap plug when using the coupler. The EA, AA, MA, ED, and JCA series are available as standard products. If you need EP, DA, or SD series products, consult us.

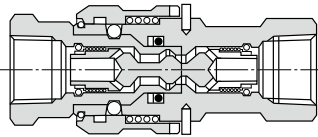
# BI - Coupler

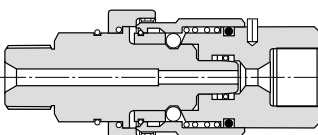
Series	Shape	Structure / Material	Max.Working Pressure	Size
<b>For Standard Pressure EA</b> <b>For Hydraulic Oil</b>		 Main Body : Steel / Stainless O-ring : NBR / FKM	<b>Steel</b> 20.5MPa  <b>Stainless</b>	<b>02 ~ 32</b> (1/8) ~ (2")
<b>For Standard Pressure ED</b> <b>For Hydraulic Oil</b>		 Main Body : Steel / Stainless O-ring : NBR / FKM	<b>04·06 → 17.0MPa</b> <b>08 → 14.0MPa</b> <b>12·16 → 7.5MPa</b> <b>20·24 → 3.5MPa</b> <b>32 → 1.5MPa</b>	<b>04 ~ 32</b> (1/4) ~ (2")
<b>For Standard Pressure AA</b> <b>For Hydraulic Oil</b>		 Main Body : Steel / Stainless O-ring : NBR / FKM	<b>27.5MPa</b>	<b>04 ~ 16</b> (1/4) ~ (1")
<b>For Standard Pressure MA</b> <b>For Hydraulic Oil</b>		 Main Body : Steel / Stainless O-ring : NBR / FKM	<b>34.5MPa</b>	<b>08 · 12 · 16</b> (1/2) (3/4) (1")
<b>With Function to Release Residual Pressure EP</b> <b>For Hydraulic Oil</b>		 Main Body : Steel O-ring : NBR	<b>20.5MPa</b>	<b>06 · 08</b> (3/8) (1/2)
<b>Flat-Face for Die-Casting ENF</b> <b>For Hydraulic Oil</b>		 Main Body : Steel O-ring : NBR	<b>20.5MPa</b>	<b>04 ~ 16</b> (1/4) ~ (1")
<b>Dust-Proof / Corrosion Resistance AA / VKF</b> <b>Mineral / Phosphoricacid Oil</b> <b>Ester Oil</b>		 Main Body : Steel / Electroless Nickel Plating O-ring : NBR / FKM	<b>27.5MPa</b>	<b>04 ~ 16</b> (1/4) ~ (1")

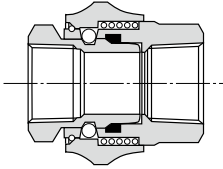

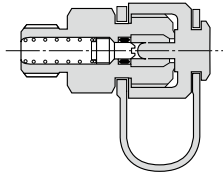
Series	Shape	Structure / Material	Max. Working Pressure	Size
<b>Brassware DA</b> Hydraulic Oil / Water		 Main Body:Brass O-ring:NBR	<b>04</b> (1/4")~ <b>08</b> (1/2") <b>7.0MPa</b> <b>12</b> (3/4")~ <b>16</b> (1") <b>3.5MPa</b>	<b>04 ~ 16</b> (1/4")~ (1")
<b>For Jack Application JCA</b> Hydraulic Oil		 Main Body:Steel O-ring:NBR	<b>30JCA06C-XXZ</b> <b>68.5MPa</b> (For jack application)	<b>04 · 06 · 08</b> (1/4") (3/8") (1/2")
<b>For Water Jet Application JA</b> Water		 Main Body:Steel O-ring:NBR	<b>30JA04B-SKFZ</b> <b>147.0MPa</b> <b>30JA04G4M4-SKFZ</b> <b>245.0MPa</b>	<b>04</b> (1/4")
<b>For Steam / Water SD</b> Steam / Water		 Main Body:Brass O-ring:NBR / FKM	<b>2.0MPa</b>	<b>12 · 16</b> (3/4") (1")
<b>For Pressure Detection BF</b> Hydraulic Oil		 Main Body:Steel O-ring:NBR	<b>27.5MPa</b>	<b>02 · 04</b> (1/8") (1/4")

### Warranty period

EA,ED,AA,MA,EP,ENF,DA  
 JCA, SD  
 JA

1 year or 400,000 impulse cycle whichever comes earlier  
 1 year or 200,000 impulse cycle whichever comes earlier  
 1 year or 25,000 impulse cycle whichever comes earlier

# Swivel Joints

For Safety's sake

Be sure to read the following before use.

**1** The Bridgestone products shown here were developed for mineral hydraulic oil hoses for hydraulic equipment. Products for other uses are also available. Refer to the usage documents and specifications for each series of products. To prevent early damage and fluid leakage, be sure to observe the instructions described below.

## 1 Handling

**Warning** Severe personal injury or death may result if these instructions are not followed.

● **Do not touch a pressurized coupling or swivel joint.**

If a product breaks, you may be burned or fluid may penetrate your skin, destroying your body tissues. If contact between your body and part of the product cannot be avoided during its use, attach sufficiently reinforced plastic hose guards to the part to ensure separation between your body and the part.

● **System working pressure should not exceed the rated working pressure.**

Excessive working pressure may damage internal components or cause fluid leakage. Adhere to the maximum working pressure ratings listed in this catalog.

● **Do not apply an electrical current to a hose assembly.**

Electrifying may lead to an electric shock, damage to internal components, or fluid leakage. Do not apply an electrical current to a hose assembly.

● **Use the product with a compatible hydraulic fluid.**

Using the product with an incompatible hydraulic fluid may damage its internal components or cause fluid leakage. Use the product only with the compatible hydraulic fluid specified in this catalog.

**Caution** Personal injury or property damage may result if these instructions are not followed

● **Avoid usage exceeding the applicable temperature.**

Usage exceeding the applicable temperature may damage internal components or cause fluid leakage. Be sure to use the swivel joint at a temperature within the specified range.

● **Avoid excessive vibration or external force.**

Excessive vibration or external force may quickly result in fluid leakage or damage to the product. Do not apply excessive vibration or external force.

● **Avoid vacuum pressure**

Vacuum pressure may damage the internal components or cause their loss. When the product is normally pressurized after being subjected to vacuum pressure, fluid leakage may occur.

● **Do not repair or modify the swivel joint.**

Doing so may deteriorate performance and quickly result in fluid leakage or damage.

● **Do not submerge the swivel joint in water or any other liquid.**

Doing so may corrode the swivel joint and quickly result in fluid leakage or damage.

## 2 Installation

**Caution**

● **Properly tighten the parts using the torques specified below.**

The use of an inappropriate torque makes it difficult to ensure proper sealing and may cause fluid leakage or damage to the joint.

● **Install the swivel joint by fixing its shaft and rotating its housing.**

If you fix the housing, the joint may loosen and detach.

● **Do not connect two swivel joints together.**

If you connect two swivel joints together, an unbalanced load may be applied to them depending on the hose movement, damaging them.

Swivel joint made of steel or stainless

Designation	Size	04	06	08	12	16	20	24	32
Tapered pipe thread: R, Rc*1 (reference values)		25	34	64	140	210	250	310	620
Parallel pipe thread: G		25	34	64	132	196	225	255	412

Unit: N-m

\*1: The tightening torque for the R thread varies depending on how its sealing tape is wrapped. Therefore, the values shown in the table are for reference only.

## 3 Warranty Period

Warranty is effective until the predetermined usage period expires or the impulse cycle count reaches the predetermined value, whichever occurs first.

## 4 Preventive Maintenance

Before every usage, check for any leakage from the products. If any leakage is discovered, replace the product with a new one immediately.

## 5 Storage

Store at a temperature between -10°C and +40°C avoiding direct sunlight, and in a dry and clean place free from hazardous gases.

# How to Install a Swivel Joint

**1**  **Caution** Do not install the swivel joint with an offset.  
Excessive force (unbalanced load) could damage the joint.

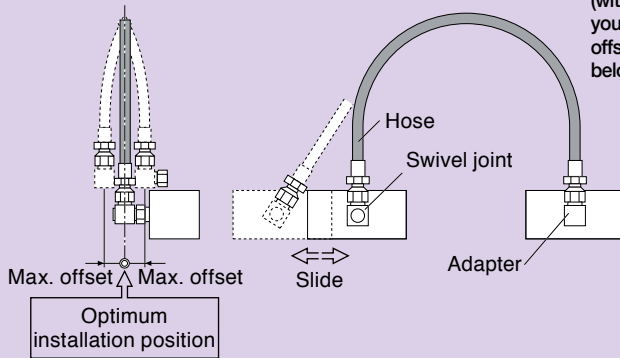



Whenever practicable, install swivel joints on the same plane (with an offset of 0mm) as the direction of hose movement. If you need to install them with an offset for plumbing, the offset should not exceed the maximum amounts given below. If it exceeds the maximum, reroute the hoses.

Size	Max. offset (mm)
04	±15
06	±15
08	±15
12	±25
16	±25
20	±35
24	±35
32	±35

**2**  **Caution** Do not install a hose so that it is taut. Ensure there is sufficient slack in the hose when you install it.

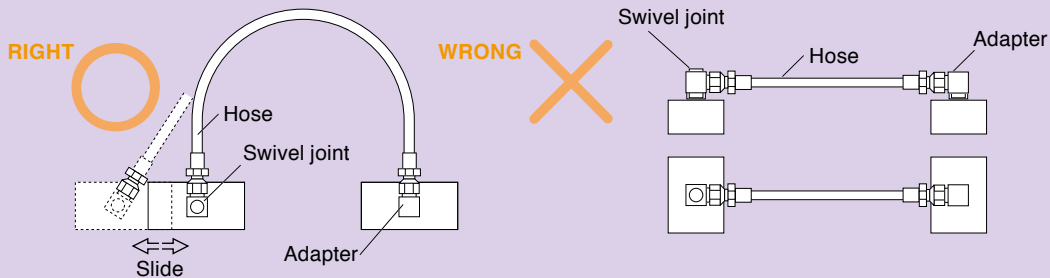
The length of a hose changes when it is pressurized. If a taut hose is installed, excessive force (unbalanced load) is applied to the swivel joint when the hose is pressurized.



**3**  **Caution** Install the swivel joint by fixing its shaft and rotating its housing.

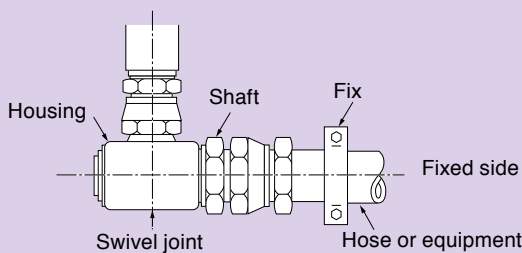

**5**  **Caution** Do not connect two swivel joints together.

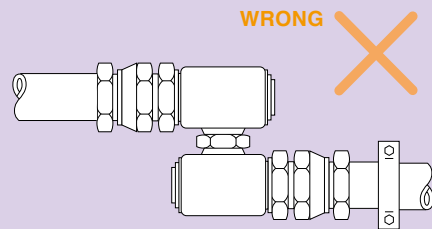

**4**  **Caution** Do not install the swivel joint in a way that applies excessive force (unbalanced load) to the joint for rotation, as shown in Figure (B) below. The joint should be installed at a right angle to the fixed side as shown in Figure (A).

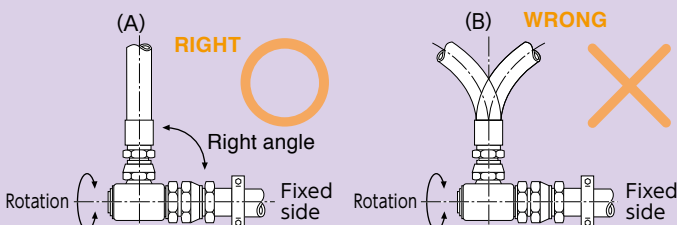

# Swivel Joints

## Features

Swivel joints for mineral hydraulic oil hoses for civil engineering machines, machine tools, and ordinary hydraulic equipment

1. A swivel joint allows a high pressure hose to be oriented in any direction, facilitating plumbing and reducing installation time.
2. A swivel joint helps the hose to bend. This decreases the hose length and prevents the hose from being sharply bent from the joint.
3. Different types of swivel joint threads are available depending on the standard for the high-pressure hose joint.
4. A swivel joint can be easily rotated 360 degrees even if it is pressurized by exerting fluid pressure on the high-pressure hose to which it is attached.
5. The swivel joints are small and lightweight.
6. The swivel joints are designed to reduce pressure loss.
7. The swivel joints are dust-proof and corrosion-proof devices suitable for a wide range of applications such as construction machinery and industrial vehicles.



Usage example

### JIS Pressure Wave ( ISO Pressure Wave )

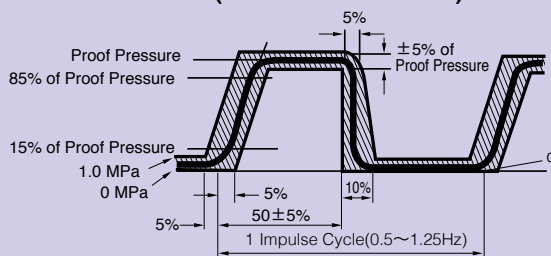

Proof pressure is maximum working pressure x 1.33.  
In case of jack application, proof pressure is the same as maximum working pressure.

- JL and JB series passed 400,000 impulse test with JIS pressure wave. These products passed 100,000 times Swing test (Swing Angle 120°, Swing speed 15 cpm)
- JR series passed 100,000 rotation of maximum working pressure enclosure test (100 rpm)

### Structure

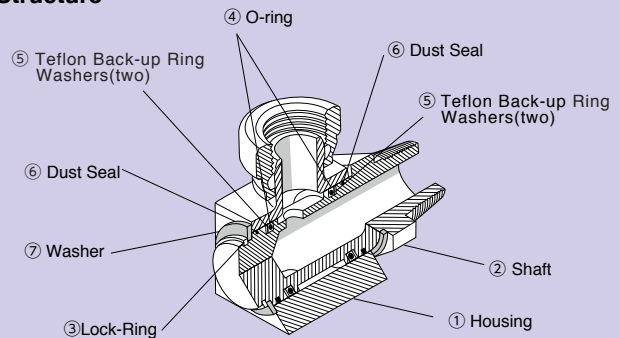

Applicable Rotation Number : Max 10 rpm with swing speed less than 60°/s

## Warranty Period

JL / JB series 1 year or 400,000 impulse cycle and 100,000 times swing whichever comes earlier

JR series 1 year or 100,000 impulse cycle whichever comes earlier

## Pressure

Main body: Steel Surface: Zinc plating or chromate treatment O-ring: NBR Applicable temperature range: -30°C to 100°C

Unit: N-m

Thread	Tapered pipe thread (R)		Parallel pipe thread (G)		Thread	Tapered pipe thread (R)		Parallel pipe thread (G)	
	Max. W.P	Min. B.P	Max. W.P	Min. B.P		Size	Max. W.P	Min. B.P	Max. W.P
04	20.5	82.0	20.5	82.0	16	20.5	82.0	20.5	82.0
06	20.5	82.0	20.5	82.0	20	20.5	82.0	17.0	68.0
08	20.5	82.0	20.5	82.0	24	14.0	56.0	10.5	42.0
12	20.5	82.0	20.5	82.0	32	10.5	42.0	10.5	42.0

The same pressure value applies to swivel joints and rotary joints.

## Product Series and Sizes

Bore	JL-GC	JL-GD	JL-GG	JL-GAO	JL-GL	JL-DC	JL-DD	JL-DG	JL-DL	JL-CC	JL-CD	JL-CG	JL-CL	JL-KC	JL-KL	JL-LC	JL-LD	JL-LK	JL-LG	JL-LL	JB-DD	JB-LD	JR-DC
04	●	●	●	●	●	●	●	●	●	●	●	●	●	●	●	●	●	●	●	●	●	●	●
06	●	●	●	●	●	●	●	●	●	●	●	●	●	●	●	●	●	●	●	●	●	●	●
08	●	●	●	●	●	●	●	●	●	●	●	●	●	●	●	●	●	●	●	●	●	●	●
12	●	●	●	●	●	●	●	●	●	●	●	●	●	●	●	●	●	●	●	●	●	●	●
16	●	●	●	●	●	●	●	●	●	●	●	●	●	●	●	●	●	●	●	●	●	●	●
20	●	●	●	●	●	●	●	●	●	●	●	●	●	●	●	●	●	●	●	●	●	●	●
24	●	●	●	●	●	●	●	●	●	●	●	●	●	●	●	●	●	●	●	●	●	●	●
32	●	●	●	●	●	●	●	●	●	●	●	●	●	●	●	●	●	●	●	●	●	●	●

\*For information about delivery dates, contact us.

# Series

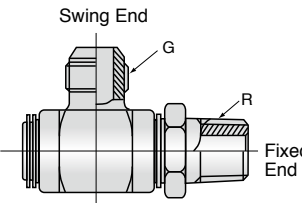
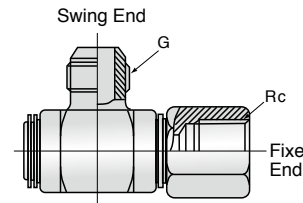
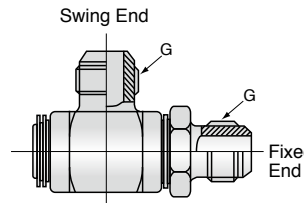
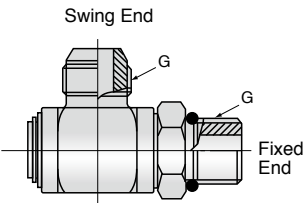
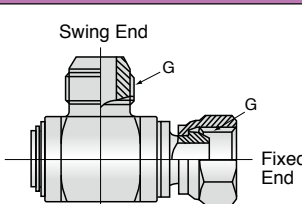
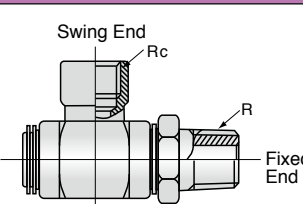
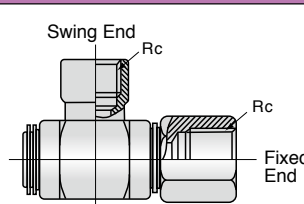
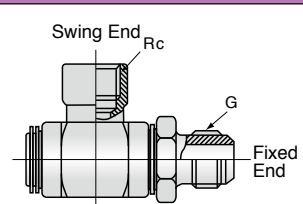
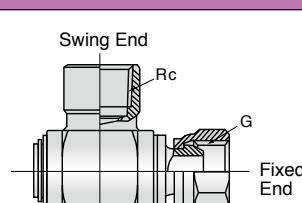
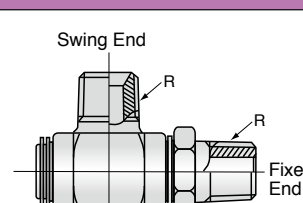
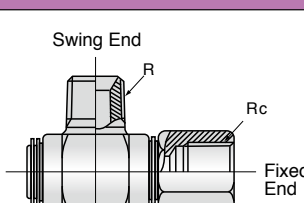
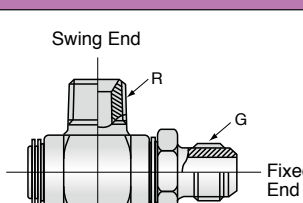
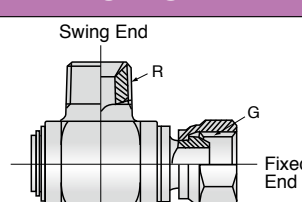
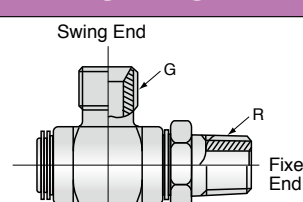
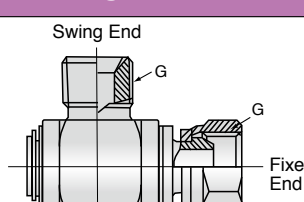
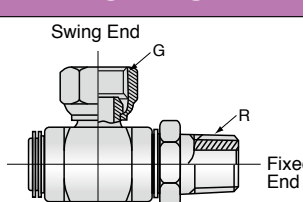
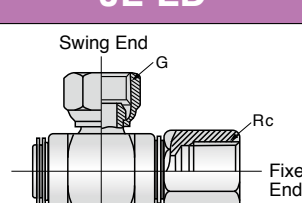
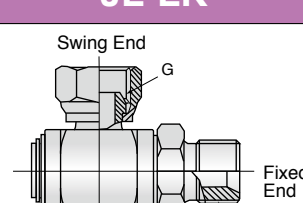
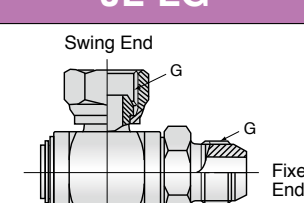
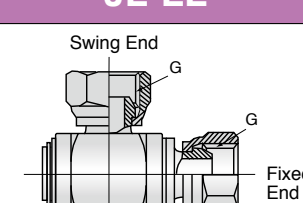
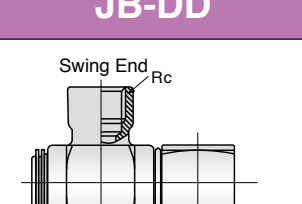
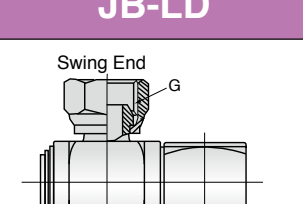
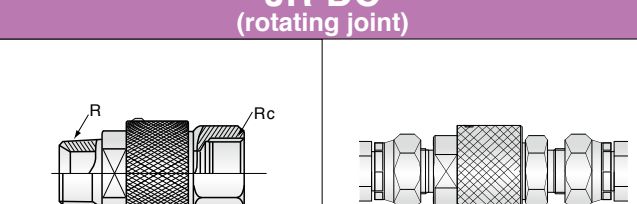
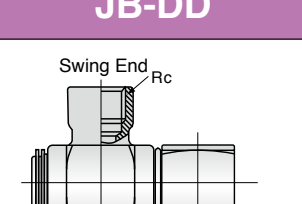
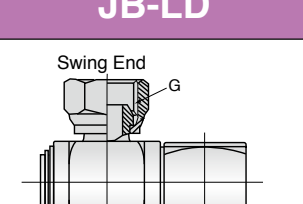
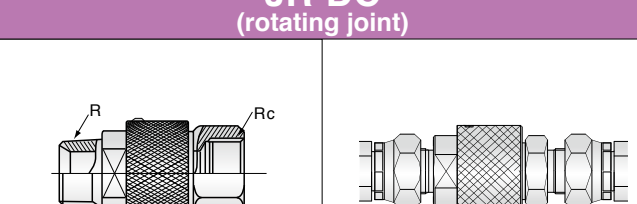
<p><b>JL-GC</b></p> 	<p><b>JL-GD</b></p> 	<p><b>JL-GG</b></p> 	<p><b>JL-GAO</b></p>  <p>O-ring seal</p>
<p><b>JL-GL</b></p> 	<p><b>JL-DC</b></p> 	<p><b>JL-DD</b></p> 	<p><b>JL-DG</b></p> 
<p><b>JL-DL</b></p> 	<p><b>JL-CC</b></p> 	<p><b>JL-CD</b></p> 	<p><b>JL-CG</b></p> 
<p><b>JL-CL</b></p> 	<p><b>JL-KC</b></p> 	<p><b>JL-KL</b></p> 	<p><b>JL-LC</b></p> 
<p><b>JL-LD</b></p> 	<p><b>JL-LK</b></p> 	<p><b>JL-LG</b></p> 	<p><b>JL-LL</b></p> 
<p><b>JB-DD</b></p> 	<p><b>JB-LD</b></p> 	<p><b>JR-DC</b> (rotating joint)</p> 	
<p><b>JB-DD</b></p> 	<p><b>JB-LD</b></p> 	<p><b>JR-DC</b> (rotating joint)</p> 	

# Accessories for Protection

## Standard Spring Guard — Catalog No,8XA○○○

■ For the protection of the crimped portion.

Sample markings (for factory-crimped PA0706)

8XA

Standard Spring

213

Inner Diameter of Spring Guard. (213 : spring I.D.=21.3mm)  
Refer to the chart in pp. 58-59 for the combination of hose and spring I.D.



## Overall Length Spring Guard — Catalog No,8XB○○○

■ For the protection for hose entire length from external damage

■ If the overall-length spring guard is ordered, the first three characters of the catalog number are changed from 8XA for the standard spring above to 8XB.

Sample markings (for factory-crimped KF04)

8XB

Overall Length

160

Inner Diameter of Spring Guard. (160 : spring I.D.=16.0mm)  
Refer to the chart in pp. 59 for the combination of hose and spring I.D.



## Braided Steel Wire

\*The length tolerance for exterior equipment is up to 5% of the product length.

■ For the protection for hose entire length from external damage.

Example

PA1408-GG

Put "-GG" at the end of hose catalog No.  
For Braid Stainless Steel Wire, put "-SS".



## Glass-Wool + Braided Steel Wire

\*The length tolerance for exterior equipment is up to 5% of the product length.

Example

EQ1712-GA

Put "-○○" (shown above) at the end of hose catalog No.

GA	1 layer of Glass Wool +1layer of Braided Steel Wire.
GW	2 layer of Glass Wool +1layer of Braided Steel Wire.
GN	3 layer of Glass Wool +1layer of Braided Steel Wire.
SA	1 layer of Glass Wool +1layer of Braided Stainless Steel Wire.

Exterior glass wool is effective in protecting the hose against momentary fires and high temperatures. It may not exhibit the expected heat insulating effect if it is used continuously at a high temperature.

## Plastic Guard — Catalog No,8XE○○○ \*The length tolerance for exterior equipment is up to 5% of the product length.

For the protection for hose entire length from external damage.



Standard Spring Guard — Catalog No, 8XA○○○

Overall Length Spring Guard — Catalog No, 8XB○○○



\*To order the overall-length spring guard, change catalog number 8XA○○○ for the standard spring guards below to 8XB○○○.

## Standard Spring Guard . For factory-cripped products

For information about the method of indicating the catalog numbers, refer to page 76.

Hose Series	Hose Size												
	02	03	04	05	06	08	10	12	14	16	20	24	32
PA01			▲8XA168 ■8XA173	—	▲8XA205 ■8XA213	▲8XA250 ■8XA239	—	—	—	—	—	—	—
PA03			▲8XA168 ■8XA173	—	▲8XA205 ■8XA213	▲8XA250 ■8XA239	8XA270	8XA345	—	8XA400	8XA505	8XA560	—
PA07			8XA180	—	8XA221	8XA247	8XA305	8XA333	—	8XA410	8XA520	8XA545	8XA735
PA10			8XA180	—	8XA221	8XA247	8XA305	8XA333	—	8XA410	8XA520	8XA545	8XA735
PA14			8XA180	—	8XA221	8XA247	8XA305	8XA333	—	8XA410	8XA520	8XA567	8XA735
PA17			8XA180	—	8XA221	8XA247	8XA305	8XA333	—	8XA410	—	—	—
PA21			8XA180	—	8XA224	8XA254	8XA305	8XA333	—	8XA410	8XA520	8XA567	8XA735
PA28			8XA180	—	8XA224	8XA254	8XA305	8XA333	—	8XA410	8XA520	8XA665	8XA820
PA35			8XA180	—	8XA224	8XA254	8XA305	8XA333	—	8XA415	8XA548	8XA665	8XA800
PF07			8XA180	—	8XA221	8XA247	—	—	—	—	—	—	—
PF14			8XA180	—	8XA221	8XA247	—	—	—	—	—	—	—
PF17	—	—	8XA180	—	8XA221	8XA254	—	—	—	—	—	—	—
PF21	—	—	8XA180	—	8XA224	8XA254	8XA305	8XA333	—	8XA410	—	—	—
PFW	—	—	8XA180	—	8XA224	8XA254	—	—	—	—	—	—	—
PFH	—	—	8XA180	—	8XA224	8XA254	—	—	—	—	—	—	—
EQ17	—	—	—	—	—	8XA254	8XA305	8XA333	—	8XA410	8XA520	8XA567	—
EQ21	—	—	—	—	—	8XA254	8XA305	8XA333	—	8XA410	8XA520	8XA567	8XA780
EQ25	—	—	—	—	—	8XA254	8XA305	8XA333	—	8XA410	8XA520	8XA665	—
EQ28	—	—	—	—	—	8XA254	8XA305	8XA333	—	8XA410	8XA548	8XA665	—
EQ31	—	—	—	—	—	8XA254	8XA305	8XA333	—	8XA415	8XA548	8XA665	8XA800
OKE	—	—	8XA145	—	8XA180	8XA222	8XA270	8XA320	—	8XA395	8XA500	8XA570	8XA720
VW	—	—	—	—	—	—	—	—	—	8XA400	8XA505	8XA560	8XA727
JW7004	—	—	8XAJW70	—	—	—	—	—	—	—	—	—	—
JW7006	—	—	—	—	8XA239	—	—	—	—	—	—	—	—
JW7008	—	—	—	—	—	8XA254	—	—	—	—	—	—	—
JWK	—	—	8XA210	—	8XA263	8XA300	—	—	—	—	—	—	—
LP	—	—	—	—	8XA218	8XA253	—	8XA330	—	8XA410	—	—	8XA735
WE21	—	—	8XA180	—	8XA224	8XA254	—	8XA355	—	8XA415	8XA548	8XA665	8XA780
NW21	—	—	8XA173	—	8XA224	8XA254	—	—	—	—	—	—	—
WA14	—	—	8XA173	—	8XA213	8XA239	—	—	—	—	—	—	—
WAR	—	—	8XA173	—	8XA213	8XA239	—	—	—	—	—	—	—
WJ	—	—	8XA180	—	8XA221	8XA247	—	8XA333	—	8XA410	—	—	—
WB21	—	—	8XA180	—	8XA221	8XA247	—	8XA333	8XA380	8XA410	—	—	—
WH21	—	—	—	—	8XA213	—	—	—	—	—	—	—	—
R1A	—	8XA146	8XA177	—	8XA210	8XA239	—	8XA325	—	8XA408	8XA520	8XA560	8XA710
R2A	—	8XA173	8XA188	—	8XA233	8XA256	—	8XA343	—	8XA425	—	—	—
KF	—	—	8XA160	—	8XA210	8XA258	—	8XA317	—	—	—	—	—
KG	—	—	—	—	8XA210	8XA258	—	—	—	—	—	—	—
SPL	—	8XA120	8XA143	—	8XA190	8XA233	—	—	—	—	—	—	—
KA	8XA098	8XA138	8XA160	8XA188	8XA203	8XA258	—	8XA317	—	—	—	—	—

**Notes**  
 1. Check the applicable couplings. They should be the series of devices shown in this catalog.  
 2. The markings prefixed to certain product names indicate the springs for those series of couplings, as follows.  
 ▲...Spring for AS  
 ■...Spring for UL

\*Spring codes for these series of factory-cripped couplings.  
 If you are using a different series of couplings from those specified above, contact us.

# Accessories for Protection

Hose Series	Hose Size												
	02	03	04	05	06	08	10	12	14	16	20	24	32
KB	—	8XA138	8XA160	8XA185	8XA210	8XA258	—	8XA317	—	8XA408	—	—	—
AG10	—	—	8XA143	—	8XA190	8XA233	—	—	—	—	—	—	—
PS	—	8XA138	8XA160	8XA185	—	—	—	—	—	—	—	—	—
PC	—	—	8XA160	—	—	—	—	—	—	—	—	—	—
WSH	—	—	8XA160	—	8XA210	—	—	—	—	—	—	—	—
JC70	—	8XA188	—	—	—	—	—	—	—	—	—	—	—
SF	—	—	8XA145	—	8XA195	8XA240	8XA253	—	8XA310	—	—	—	—
JAM	—	8XA235	—	8XA256	—	—	—	—	—	—	—	—	—
JAL	—	8XA180D25	8XA185D25	8XA210	8XA240	8XA302	8XA356	8XA400	—	8XA456	—	—	—
JAK	—	—	8XA190D25	8XA205	8XA240	8XA280	—	—	—	—	—	—	—
JKY	—	—	8XA190D25	—	—	—	—	—	—	—	—	—	—

\*Spring codes for these series of factory-crimped couplings. If you are using a different series of couplings from those specified above, contact us.

## Overall Length Spring Guard For UNICRIMP-crimped products

For information about the method of indicating the catalog numbers, refer to page 70.

Hose Series	Hose Size								
	04	06	08	10	12	16	20	24	32
PA01	▲8XB168MA ■8XB170MA	▲8XB210MA ■8XB215MA	▲8XB260MA ■8XB239MA	—	—	—	—	—	—
PA03	▲8XB168MA ■8XB170MA	▲8XB210MA ■8XB215MA	▲8XB260MA ■8XB239MA	8XB284MA	8XB355MA	8XB400MA	8XB505MA	8XB560MA	—
PA07	8XB180MA	8XB215MA	8XB260MA	8XB300MA	8XB340MA	8XB410MA	8XB538MA	8XB555MA	8XB740MA
PA10	8XB180MA	8XB215MA	8XB260MA	8XB300MA	8XB340MA	8XB410MA	8XB538MA	8XB555MA	8XB745MA
PA14	8XB180MA	8XB215MA	8XB260MA	8XB300MA	8XB340MA	8XB410MA	8XB538MA	8XB580MA	8XB745MA
PA17	8XB180MA	8XB215MA	8XB260MA	8XB300MA	8XB340MA	8XB410MA	—	—	—
PA21	8XB180MA	8XB215MA	8XB260MA	8XB300MA	8XB340MA	8XB410MA	8XB538MA	8XB580MA	8XB745MA
PA28	8XB180MA	8XB215MA	8XB260MA	8XB300MA	8XB340MA	8XB410MA	8XB538MA	—	—
PA35	8XB180MA	8XB215MA	8XB260MA	8XB300MA	8XB340MA	8XB410MA	8XB538MA	—	—
PFH	8XB180MA	8XB215MA	8XB260MA	—	—	—	—	—	—
EQ17	—	—	8XB260MA	8XB300MA	8XB340MA	8XB410MA	8XB538MA	8XB580MA	—
EQ21	—	—	8XB260MA	8XB300MA	8XB340MA	8XB410MA	8XB538MA	8XB580MA	—
EQ25	—	—	8XB260MA	8XB300MA	8XB340MA	8XB410MA	8XB538MA	—	—
EQ28	—	—	8XB260MA	8XB300MA	8XB340MA	8XB410MA	8XB538MA	—	—
EQ31	—	—	8XB260MA	8XB300MA	8XB340MA	8XB410MA	8XB538MA	—	—
OKE	8XB150MA	8XB180MA	8XB226MA	8XB273MA	8XB310MA	8XB390MA	8XB500MA	8XB570MA	8XB720MA
WA14	8XB170MA	8XB215MA	8XB239MA	—	—	—	—	—	—
WAR	8XB170MA	8XB215MA	8XB239MA	—	—	—	—	—	—
WJ	8XB180MA	8XB215MA	8XB260MA	—	8XB340MA	8XB410MA	—	—	—
WB21	8XB180MA	8XB215MA	8XB260MA	—	8XB340MA	8XB410MA	—	—	—
KF	8XB160MA	8XB210MA	8XB258MA	—	8XB340MA	—	—	—	—
KG	—	8XB210MA	8XB258MA	—	—	—	—	—	—
SPL	8XB143MA	8XB200MA	8XB244MA	—	—	—	—	—	—
KA	8XB170MA	8XB215MA	8XB239MA	—	8XB340MA	—	—	—	—
KB	8XB170MA	8XB215MA	8XB239MA	—	8XB340MA	8XB430MA	—	—	—
AG10	8XB143MA	8XB200MA	8XB244MA	—	—	—	—	—	—
WSH	8XB160MA	8XB210MA	—	—	—	—	—	—	—

**Notes**

1. Check the applicable couplings. They should be the series of devices shown in this catalog.
2. The markings prefixed to certain product names indicate the springs for those series of couplings, as follows.  
▲...Spring for AS  
■...Spring for UL

\*Spring codes for these series of factory-crimped couplings. If you are using a different series of couplings from those specified above, contact us.



# How to calculate Hose Exposed Length

## Minimum exposed length of hoses that can be manufactured

Hose Series (mm)	02	03	04	05	06	08	10	12	16	20	24	32	40	48
Actual hose internal diameter	3.2	4.8	6.3	7.9	9.5	12.7	15.9	19.0	25.4	31.8	38.1	50.8	63.5	76.2
Min. exposed length of hose that can be manufactured	150	150	150	150	160	170	180	190	210	220	350	370	400	400
Bridgestone PrimoLine	—	200	200	200	200	200	200	210	210	—	—	—	—	—

● For information about the method of indicating assembly hose lengths, refer to "Example Indications of Hose Length and Orientation Angle" on page 5. For dimensions of fittings, refer to the specifications of the coupling dimensions for each series of hose. ● If you need to use a hose with exterior protection, consult us. ● Minimum exposed lengths may differ from the values above depending on the combination of hoses and couplings.

**1 U-shaped hose fixed at both ends**

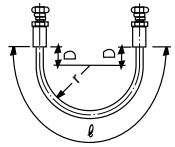

● Exposed hose length:  
 $R = \pi(r + D/2) + 2D$

**2 U-shaped hose fixed at one end, the other end moved by T**

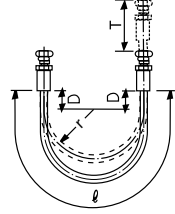

● Exposed hose length:  
 $R = \pi(r + D/2) + 2D + T$

**3 Min. exposed length of hose that can be manufactured**

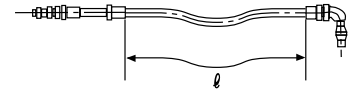

● Same as above

R: Exposed hose length r: Minimum bending hose radius T: Distance  $\pi$ : Circular constant D: Hose external diameter

## Hose Assembly Installation

Satisfactory performance and appearance depends upon proper hose installation. Excessive length destroys the trim appearance of an installation and adds unnecessary costs to the equipment. Hose assemblies of insufficient length to permit adequate flexing, expansion or contraction will cause poor power transmission and shorten the life of the hose.

The diagrams below offer suggestions for proper hose installations to obtain the maximum performance and economy.

**1**



If the bending radius falls below the required minimum, install an elbow adapter as shown above to avoid sharp bends in the hose.

**2**



Use an adapter to avoid sharp twists or bends in the hose.

**3**

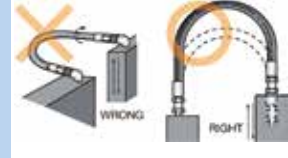

To avoid twists, bend the hose on the same plane as the direction of movement of the base to which the hose is connected.

**4**



Obtain direct routing of hoses by using an adapter. You can arrange the hoses neatly by avoiding the use of excessively long hoses.

**5**



There will be some change in length when the hose is pressurized. Do not clamp the hose at the bends in an attempt to avoid the length change. (If the piping design cannot be changed, protect the hose with springs and external wire braid instead of clamping.)

**6**



The hose should have an adequate amount of slack. This slack permits smooth hose movement and prevents sharp bends in the hose.

**7**

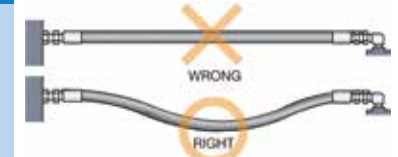

The length of a hose changes by about 4% when it is under pressure. Provide an adequate amount of slack to allow for expansion and contraction.

**8**

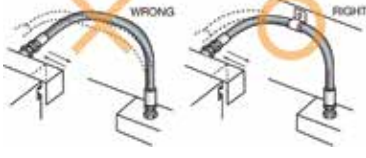

Three-plane bending could result in the hose developing twists when it is under pressure. When the hose moves as shown in the figure on the left, it always twists. Therefore, using the attached tool, clamp the hose so that it moves on only one plane to prevent it from developing twists.

**9**

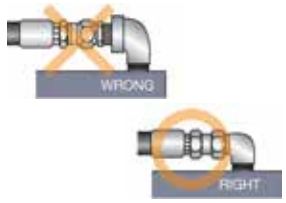

By selecting appropriate adapters, you can decrease the number of coupling parts and thereby improve the seal reliability and coupling appearance.

**10**



Use the lay line provided on the hose as a reference to examine whether or not the installed hose is twisted. Also, when using a coupling equipped with a union nut, be sure to fix it by tightening the hexagonal portion of the torsion preventive part with a wrench.

## Length Tolerances

Hose assembly length (mm)	Tolerance
Less than 500	+10mm 0
500 or more and less than 1,000	+15mm 0
1,000 or more and less than 2,000	+20mm 0
2,000 or more and less than 5,000	+1.0% 0
5,000 or more	+2.0% 0

\*Length tolerance for exterior equipment is up to 5% of the product length.

## Pressure Loss

When a liquid flows inside the hose, pressure loss occurs due to friction. You can calculate the approximate pressure loss as follows.

### Conditions

Hose Length : 10m  
(Excluding Coupling Lengths)  
Fluid : Hydraulic Oil  
Kinetic Viscosity : 32.0mm<sup>2</sup>/S

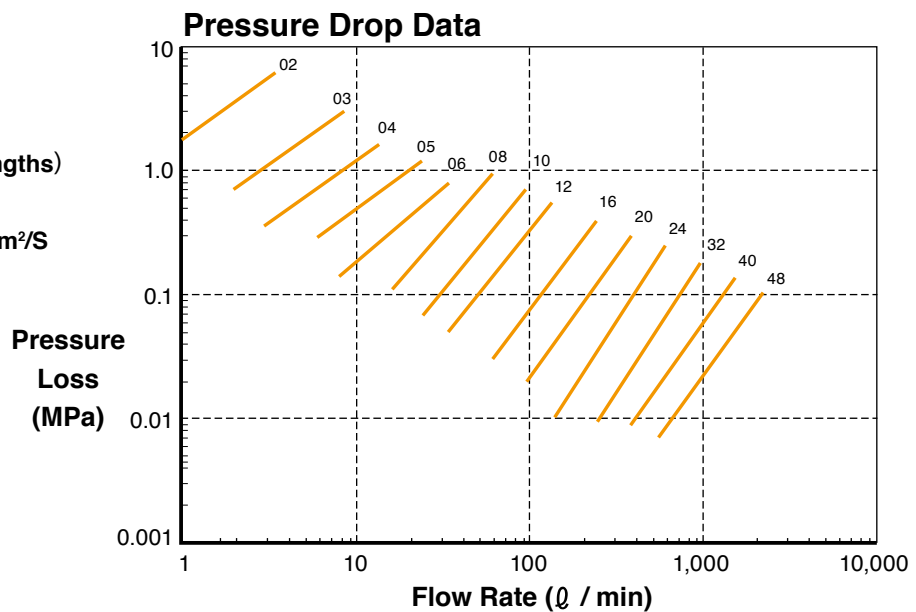

## Example

Hose I.D.-12 (19mm), Length 5m (with couplings at both ends), Kinetic viscosity 32mm<sup>2</sup>/s , Flow rate 80 ℓ /min

- 1) By the flow rate 80ℓ/min and hose I.D.-12, find the hose pressure loss as 0.2 MPa from the graph above.
- 2) Pressure loss of a coupling is about the same as 1/10 of that of the hose.

$$0.2\text{MPa} \times \frac{5\text{m}}{10\text{m}} + 0.2\text{MPa} \times \frac{1}{10} \times 2\text{pcs} = 0.14\text{MPa}$$

hose pressure loss

coupling pressure loss

assembly hose pressure loss

- 3) 0.14MPa is estimated pressure loss of this hose assembly.

# Relational Table of Flow Rate / Velocity / Hose Size

## Relational Table of FlowRate/Velocity/Internal Hose Diameter

By using this table, you can easily determine the internal diameter of the hose, as follows.

### Determining the internal diameter of a hose to supply liquid at a flow rate of 30 liters/minute

The flow rate of your system requirement is 150cm<sup>3</sup> per second. Connect your straight edge from the 150cm<sup>3</sup> per second flow rate column to the Recommendable flow velocity range for pressure lines of 4 meters per second. The straight edge intersects at 04, so the recommended hose size is 04.

The equation below shows the relationship between flow rates, velocities, and internal diameters.

$$Q = 0.0471 V d^2$$

Q : FLOW RATE ( /min)

V : VELOCITY (m/min)

d : HOSE SIZE:ID.(mm)

ℓ/min, FLOW RATE cm<sup>3</sup>/sec

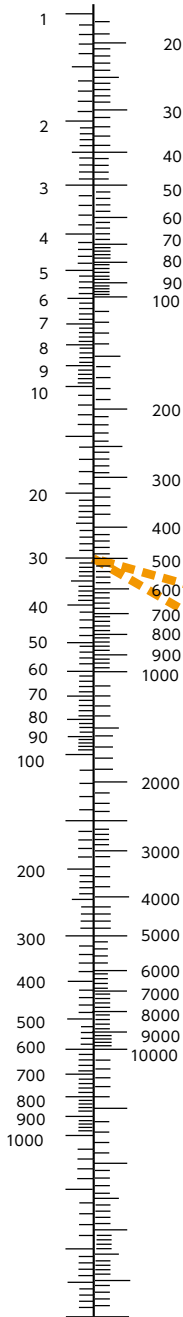

VELOCITY m/sec

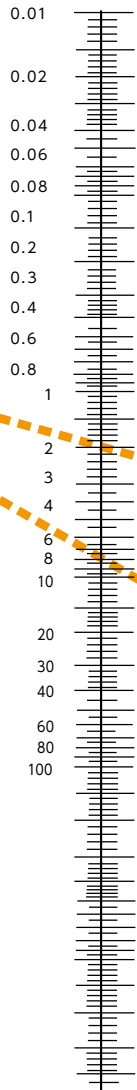

SECTIONAL AREA OF HOSE(cm<sup>2</sup>)

Hose internal diameter (in 1/16-inch increments)

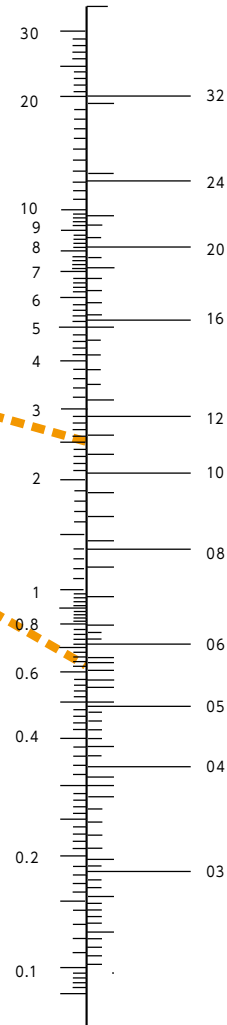

Recommendable flow velocity range

# Tightening Torque

- Follow the below tightening torque.
- The tolerance is approximately  $\pm 10\%$ .
- The application of each of the following torques is allowed on the prerequisite that there is no oil left on the threads portion and inside of the nut and also that the hexagonal part of each insert is firmly held by a spanner so as to prevent the coupling from rotating together with hose.

## Coupling (Material : Steel / Surface : Zinc Plating·Chromate Treatment)

Coupling		Hose	02	03	04	05	06	08	10	12	16	20	24	32
R type *1 (Reference values)	Pipe thread	—	—	40	—	40	70	—	—	140	210	250	310	620
	Torque N / m	15	—	*15	—	*25	*29	—	—	—	—	—	—	—
F / C type	Pipe Thread	1/8	1/4		3/8		1/2	3/4		1	1 $\frac{1}{4}$	1 $\frac{1}{2}$	2	
	Torque N / m	15	25		34		64	132		196	225	255	412	
F2 / F3 type	UNF thread	—	—	$\frac{7}{16}$ -20	$\frac{1}{2}$ -20	$\frac{9}{16}$ -18	$\frac{3}{4}$ -16	$\frac{7}{8}$ -14	$1\frac{1}{16}$ -12	$1\frac{5}{16}$ -12	$1\frac{5}{8}$ -12	—	—	
	Torque N / m	—	—	20	29	39	49	59	118	137	167	—	—	
F4 type	M thread	—	—	M14x1.5	—	M18x1.5	M22x1.5	M24x1.5	M30x1.5	M33x1.5	—	—		
	Torque N / m	—	—	25	—	49	78	137	176	196	—	—		
Q2 type	UNF thread	—	—	$\frac{9}{16}$ -18	—	$1\frac{1}{16}$ -16	$1\frac{3}{16}$ -16	1-14	$1\frac{3}{16}$ -12	$1\frac{7}{16}$ -12	$1\frac{11}{16}$ -12	2-12	—	
	Torque N / m	—	—	39	—	67	78	118	157	196	327	430	—	

\*Products marked with an asterisk are the F- and R-type couplings made of brass. \*1: The tightening torque for the R joint varies depending on how its sealing tape is wrapped. Therefore, the values above are for reference only.

\*For tightening torques for PrimoLine, refer to page 59. \*Use a torque wrench for proper tightening.

- For proper tightening, use a torque wrench (shown below)



## Bolt for Split Frange (Material : Steel)

Coupling		Hose	08	10	12	16	20	24	32	40	48	
For Standard Pressure	Catalog No.	8YA08S	8YA12S			8YA20S		8YA24S				
	Torque N / m	20~25	28~40			37~48		48~62		62~79		73~90
For High Pressure	Catalog No.	8YA08S	8YA12H			8YA16H		8YA20H		8YA24H		8YA32H
	Torque N / m	20~25	33~45			56~68		85~102		151~181		271~294

## Bolt for JIS Frange (Material : Steel)

Coupling		Hose	08	10	12	16	20	24	32	40	48
For JIS21MPa (210kgf/cm <sup>2</sup> )	Catalog No.	8YAK15	8YAK25			8YAK40		8YAK65		8YAK80	
	Torque N / m	34~45	54~76			147~230		314~451		470~637	



When a split flange or a square flange is used for a hose connection, the bolts must be tightened diagonally with the same torque applied. Otherwise, the flange will incur damage, possibly followed by oil leakage.

# Certificate of Compliance with the Marine Standard

Our products have obtained a certificate of compliance with the marine standard, as shown below. Since then, they have earned a worldwide reputation.

## Products Certified for Compliance with the Marine Standard

Standard Hose	NK (Japan) Nippon Kaiji Kyokai	JG (Japan) MLIT Maritime Bureau	LR (U.K.) Lloyd's Register of Shipping	BV (France) Bureau Veritas	DNV (Norway) Det Norske Veritas	KR (Korea) Korean Bureau of Shipping	CR (Taiwan) Central Research of Shipping S.A.	ABS (U.S.A) American Bureau of Shipping	CCS (China) China Classification Society
PA07 04~32	◎	<b>For certified sizes, contact us.</b>	◎	◎	◎	◎	20~32	◎	◎
PA10 04~32	◎		◎	◎	◎	◎	20~32	◎	◎
PA14 04~32	◎		◎	◎	◎	◎	20~32	◎	◎
PA17 04~16	◎		◎	◎	◎	◎	—	◎	◎
PA21 04~32	◎		◎	◎	◎	◎	20~32	◎	◎
PA28 04~32	◎		◎	◎	◎	◎	◎	◎	◎
EQ17 08~24	◎		◎	◎	◎	◎	◎	◎	◎
EQ21 08~32	◎		◎	◎	◎	◎	◎	◎	◎
EQ25 08~24	◎		◎	◎	◎	◎	◎	◎	◎
EQ28 08~24	◎		◎	◎	◎	◎	◎	◎	◎
EQ31 08~32	◎		◎	◎	◎	◎	◎	◎	◎
R1A 03~32							◎	◎	
R2A 03~16							◎	◎	

1. Witness inspection is required each time a product is tested for certification by an organization other than CR, ABS, or DNV. Contact us.
2. When a product to be used inside an engine room is tested for certification by Bureau Veritas (BV), an external wire braid is required for that product.

## Coupling Crimping Machine UNICRIMP

### UC28

In-vehicle horizontal crimping machine capable of crimping a 34.5MPa hose of size 20 (with an internal diameter of 32mm)



**For mobile application with Maximum -20 (32mm) I.D. and 34.5MPa Hose**

Dimension : 400mm(L)×700mm(W)×400mm(H)  
Weight : 226kg (body : 190kg pump : 36kg)  
Power source : 1 - phase 100V

Complete set	Component	Catalog Number
60UC2801	Crimper	61UC 2801
	Dies set 10 sets	61DS 28
	Skive tool 4 sets	61ET 28-B
	Disk exchange set	61ET 28-A

	PA01	PA03	PA07	PA10	PA21	PA28	PA35
04	●	●	●	●	●	●	●
06	●	●	●	●	●	●	●
08	●	●	●	●	●	●	●
10		●	●	●	●	●	●
12		●	●	●	●	●	●
16		●	●	●	●	●	●
20		●	●	●	●	●	●
24		●	●	●	●		
32		●	●	●	●		

### UC25

Powerful crimping machine capable of crimping a 34.5MPa hose of size 16 (with an internal diameter of 25mm)



**Compact crimping machine with Maximum -16 (25mm) I.D. and 34.5MPa Hose**

Complete set	Component	Catalog Number
60UC2504	Crimper	61UC 25
	Pump set	61PE 21

	PA01	PA03	PA07	PA10	PA21	PA28	PA35
04	●	●	●	●	●	●	●
06	●	●	●	●	●	●	●
08	●	●	●	●	●	●	●
10		●	●	●	●	●	●
12		●	●	●	●	●	●
16		●	●	●	●	●	●
20							
24							
32							

### UC25QC

Powerful crimping machine capable of crimping a 34.5MPa hose of size 6 (with an internal diameter of 25mm)

**Compact crimping machine with Maximum -16 (25mm) I.D. and 34.5MPa Hose**

Complete set	Component	Catalog Number
60UC2504	Crimper	61UC 25
	Pump set	61PE 21



### UC28DX

Full-fledged crimping machine capable of crimping a wide variety of hoses. Mass-production is possible.



### UC27MX

Capable of crimping a 34.5MPa hose of size 20 (with an internal diameter of 32mm). The latest in-vehicle crimping machine, which is more lightweight and compact than the UC28.



**Electric pump set**  
Electrically-operated pump that offers speedy operation and excellent working efficiency. Equipped with a crimp force limiter.

